

**METAL/METAL WAFER BUTTERFLY VALVE ( NO TIGHTNESS )  
EXCELLENCE RANGE**



**BUREAU  
VERITAS**

**Marine & Offshore  
Division**



Lloyd's  
Register  
**ISO 9001 : 2015**



Lloyd's  
Register  
PED/2014/68/EU



**Certificate 3.1**

**Size :** DN 40 to 1400 mm  
**Ends :** Between flanges PN10/16 and Class 150 (PN20)  
**Min Temperature :** - 30°C  
**Max Temperature :** + 350°C  
**Max Pressure :** 16 Bars up to DN300  
**Specifications :** Long neck for isolation  
Wafer type  
Crossing stem  
ISO 5211 mounting pad

**Materials :** Stainless steel ASTM A351 CF8M body

**METAL/METAL WAFER BUTTERFLY VALVE ( NO TIGHTNESS )  
EXCELLENCE RANGE**

**SPECIFICATIONS :**

- Long neck for isolation
- ISO 5211 mounting pad
- Wafer type
- Between flanges PN10/16 and Class 150 (PN20) up to DN400 included ( over on request )
- Between flanges PN10 from DN450 to DN1400
- Crossing stem
- **No tightness , loss factor : 2% of Kvs**
- Stainless steel disc
- 9 positions lever, with locking device up to DN200 , stop in all positions but non lockable from DN250 to 300
- Stem extension 75 mm length ( option )
- Square lever 30x30 mm for special key ( option )

**USE :**

- High temperature smokes, powders
- Min and max Temperature Ts : - 30°C to + 350°C  
(\* : higher temperature on request )
- Max Pressure Ps : 16 bars up to DN300 , 10 bars over
- **Not for steam**

**RANGE :**

- With lever from DN 40 to DN 300
- Naked stem from DN 350 to DN1400
- IP65 Gear box possible ( **Ref. 1197** ) from DN 40 to DN 1400
- IP65 chain gear box possible ( **Ref. 1194** ) from DN 40 to DN 500
- On request, stem extension with special length ( **Ref. 98665** )
- On request, stainless steel lever and bolting ( **Ref. 9831250-9831264** )

**ENDS :**

- Between flanges PN10-PN16 and Class 150 (PN20) up to DN400
- Between flanges PN10 from DN450 to DN 1400

**TORQUE VALUES ( in Nm without safety coefficient ) at 10 Bars for temperature under 180°C :**

DN	40	50	65	80	100	125	150	200	250	300	350	400
Torque ( Nm )	5	5	5	5	5	10	10	15	25	35	35	45

DN	450	500	600	700	750	800	900	1000	1100	1200	1300	1400
Torque ( Nm )	120	140	300	360	420	480	600	900	1000	1100	1200	1300

**TORQUE VALUES ( in Nm without safety coefficient ) at 10 Bars for temperature over 180°C :**

DN	40	50	65	80	100	125	150	200	250	300	350	400
Torque ( Nm )	5	5	10	15	25	45	60	80	110	120	140	160

DN	450	500	600	700	750	800	900	1000	1100	1200	1300	1400
Torque ( Nm )	250	300	450	950	1050	1100	1150	1200	1300	1800	1900	2000

**METAL/METAL WAFER BUTTERFLY VALVE ( NO TIGHTNESS )  
EXCELLENCE RANGE**

**FLOW COEFFICIENT  $K_v$  (  $m^3 / h$  ) :**

DN	Opening angle									
	0°	10°	20°	30°	40°	50°	60°	70°	80°	90°
32-40	2	3	5	10	16	26	48	35	35	35
50	3	10	11	19	39	61	75	61	61	61
65	5	12	15	27	47	64	94	109	109	109
80	7	14	22	47	72	118	179	246	246	246
100	10	16	29	59	96	143	195	265	345	345
125	14	39	51	110	173	253	357	500	598	598
150	19	45	69	149	281	302	498	702	1015	1072
200	21	61	138	260	427	638	910	1388	1751	1751
250	23	95	213	407	673	1015	1473	2062	2993	2993
300	34	135	310	508	990	1490	2135	3013	4224	4507
350	76	153	341	766	881	1772	2783	3963	6190	6199
400	88	202	563	1081	1785	2687	3856	5482	8368	8792
450	95	284	669	1287	2126	3198	4579	6526	9429	9429
500	142	314	624	1416	2563	3844	5597	8019	11830	12485
600	198	399	1057	2234	3645	5941	7865	10763	15020	15020
700	257	659	1555	3164	5342	8133	11737	16764	25947	26463
750	287	687	1847	3326	6946	8994	13121	18743	28002	30946
800	302	727	2172	4151	7011	10671	15411	22030	35819	35596
900	388	1144	2824	5318	8711	13070	18744	26600	40712	40712
1000	415	996	2979	6116	10370	15789	22827	32589	50452	50452
1100	501	1622	3682	7459	12441	19495	29186	36539	64101	68797
1200	588	1463	4280	8810	14944	22800	32970	40812	68309	75485
1300	664	2378	5293	10736	17255	28441	41241	53171	71746	84294
1400	874	2608	6127	11895	21341	31295	45385	65106	75811	117171

**HEAD LOSS CALCULATIONS :**

$$\Delta p = ( Q / K_v )^2 \times SG$$

Q : flow in  $m^3/h$

$\Delta p$  : Head loss in bar

SG : Specific gravity (= 1 for water)

$K_v$  : Volume of water in  $m^3/h$ , that will flow through a given restriction or valve opening with a pressure drop of 1 bar at 20°C)

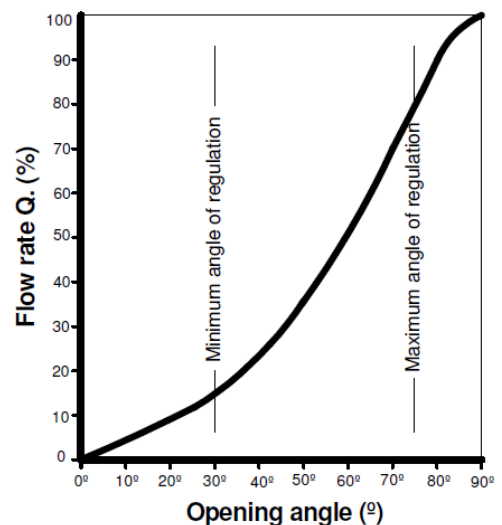

**METAL/METAL WAFER BUTTERFLY VALVE ( NO TIGHTNESS )  
EXCELLENCE RANGE**

MATERIALS DN 40 - 200 :

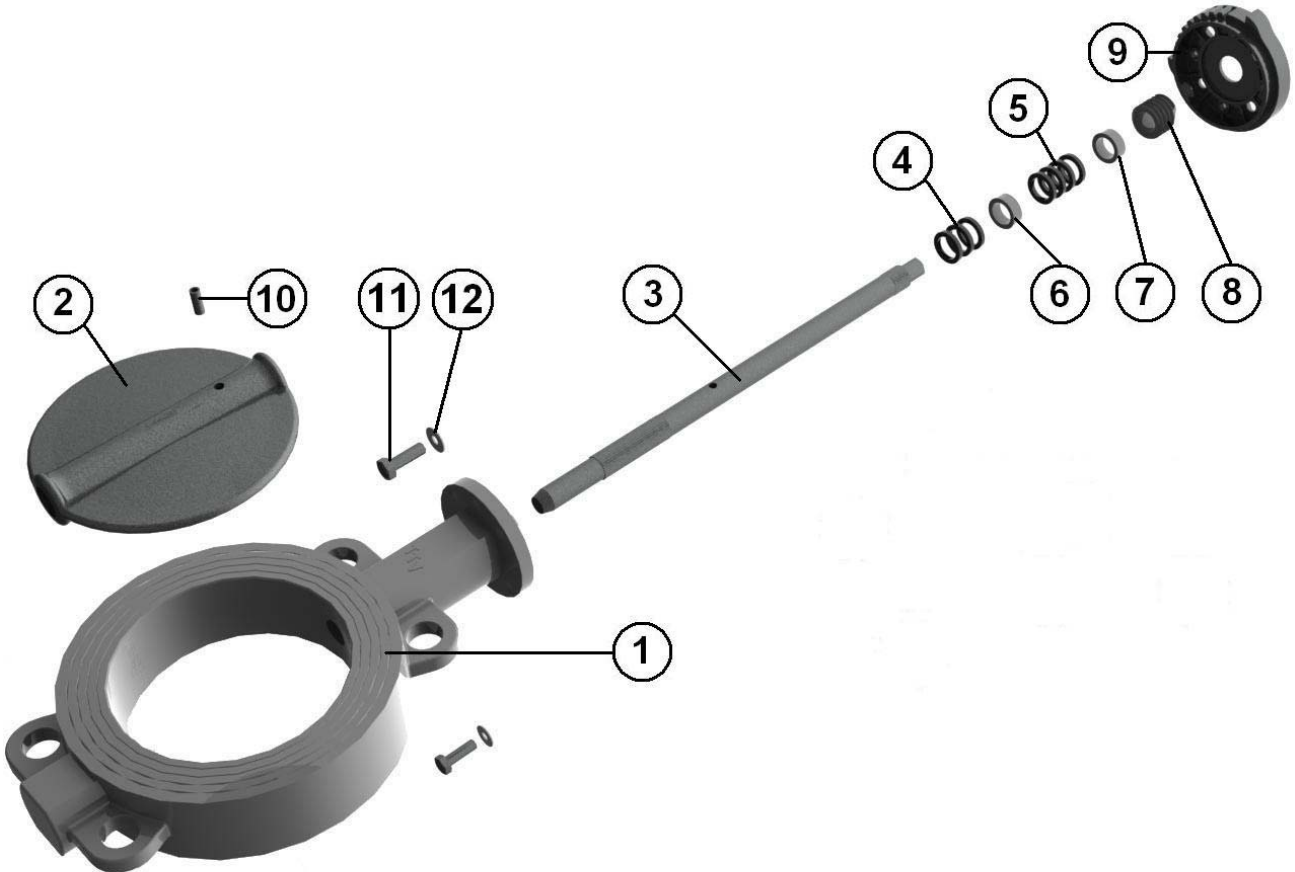

Item	Designation	Materials
1	Body	ASTM A351 CF8M
2	Disc	
3	Stem	AISI 316
4	Gasket	FILAM. GRAPHITE
5	Gasket	
6	Ring	AISI 316
7	Ring	
8	Socket	
9	Plate	ASTM A351 CF8M
10	Pin	AISI 316
11	Screw	A4
12	Washer	AISI 316I
	Lever	Aluminium ADC10 with epoxy painting 50µ thickness

**METAL/METAL WAFER BUTTERFLY VALVE ( NO TIGHTNESS )  
EXCELLENCE RANGE**

MATERIALS DN 250 - 400 :

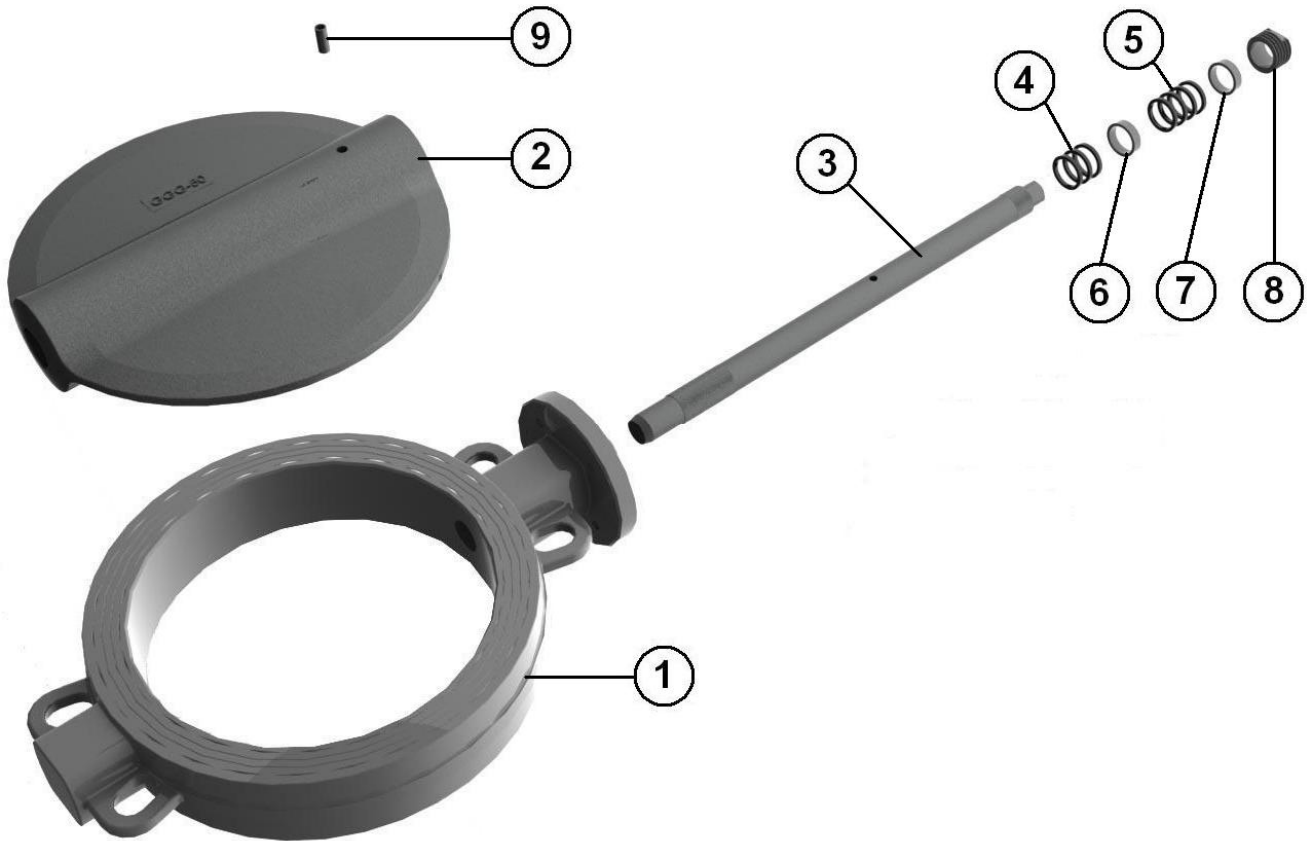

Item	Designation	Materials
1	Body	ASTM A351 CF8M
2	Disc	
3	Stem	AISI 316
4	Gasket	FILAM. GRAPHITE
5	Gasket	
6	Ring	AISI 316
7	Ring	
8	Socket	
9	Pin	
Lever ( up to DN300 )		Ductile iron EN GJS-500-7 with epoxy painting 50μ thickness

**METAL/METAL WAFER BUTTERFLY VALVE ( NO TIGHTNESS )  
EXCELLENCE RANGE**

MATERIALS DN 450 - 1400 :

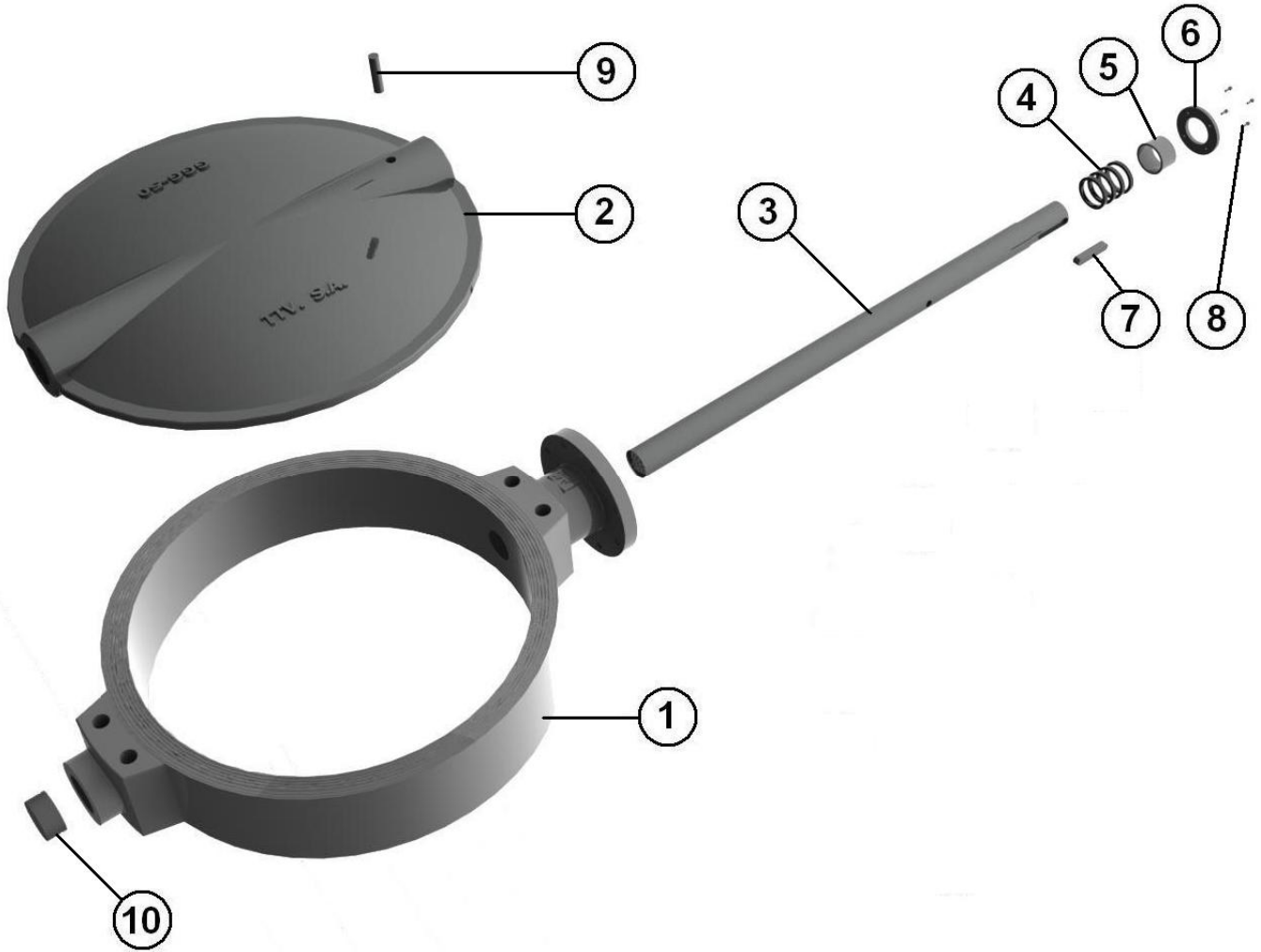

Item	Designation	Materials
1	Body	ASTM A351 CF8M
2	Disc	
3	Stem	AISI 316
4	Gasket	FILAM. GRAPHITE
5	Ring	AISI 316
6	Ring	
7	Pin	
8	Screw	
9	Pin	
10	Ring	

**METAL/METAL WAFER BUTTERFLY VALVE ( NO TIGHTNESS )  
EXCELLENCE RANGE**

**GEARBOX MATERIALS REF. 1197 :**

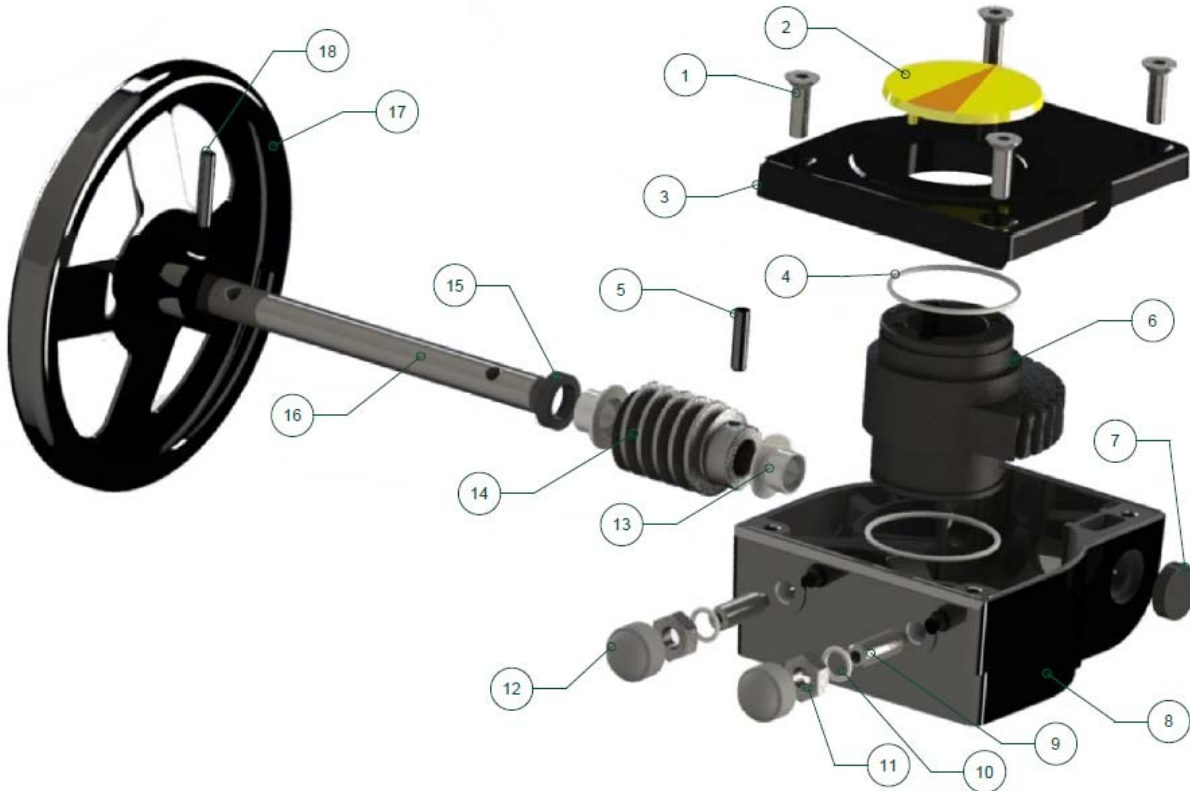

Item	Designation	Materials Ref. 1197
1	Screw	AISI 304
2	Indicator	Polypropylene
3	Cover	Aluminium
4	O ring	NBR
5	Pin	Carbon steel
6	Quadrant	Ductile iron EN GJS-400-15
7	Gasket	NBR
8	Body	Aluminium
9	Adjusting bolt	Carbon steel
10	Washer	Galvanized steel
11	Nut	Galvanized steel
12	Cap	NBR 70
13	Bushing	Bronze
14	Worm	Carbon steel 45
15	Gasket	NBR
16	Shaft	Carbon steel 45
17	Handwheel	Carbon steel
18	Pin	Carbon steel

**METAL/METAL WAFER BUTTERFLY VALVE ( NO TIGHTNESS )  
EXCELLENCE RANGE**

SIZE ( in mm ) :

- Valves DN 40 - 200 :

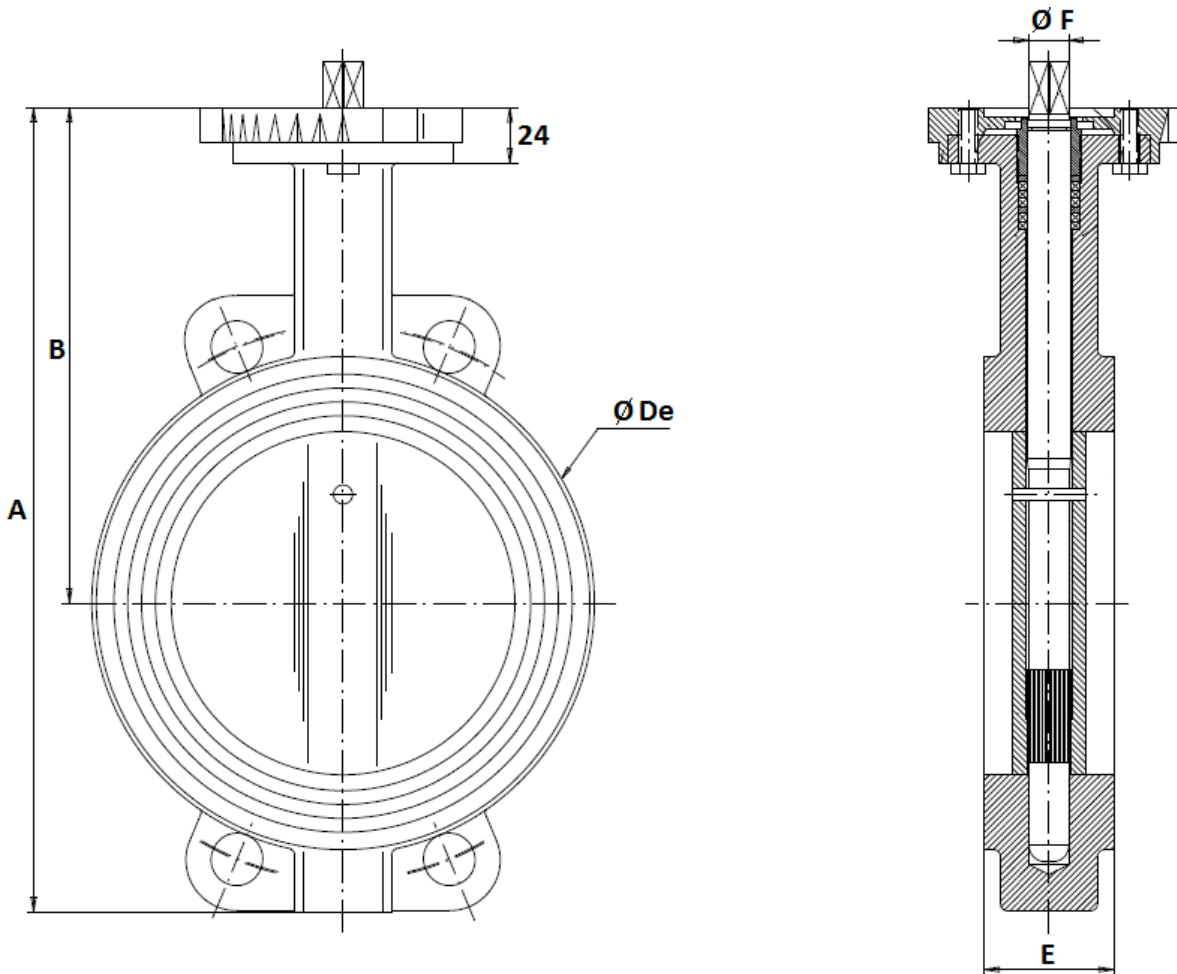

DN	40	50	65	80	100	125	150	200
A	205	228	248	265	298	331	349	430
B	140	156	161	169	187	206	215	255
Ø De	82	102	119	135	155	185	208	270
E	33	43	46	46	52	56	56	60
Ø F	9.5	9.5	12	14	14	17	17	21
Weight (Kg)	3.07	4.57	4.89	5.95	7.58	10.22	12.23	19



**METAL/METAL WAFER BUTTERFLY VALVE ( NO TIGHTNESS )  
EXCELLENCE RANGE**

SIZE ( in mm ) :

- Valves DN 250 -400 :

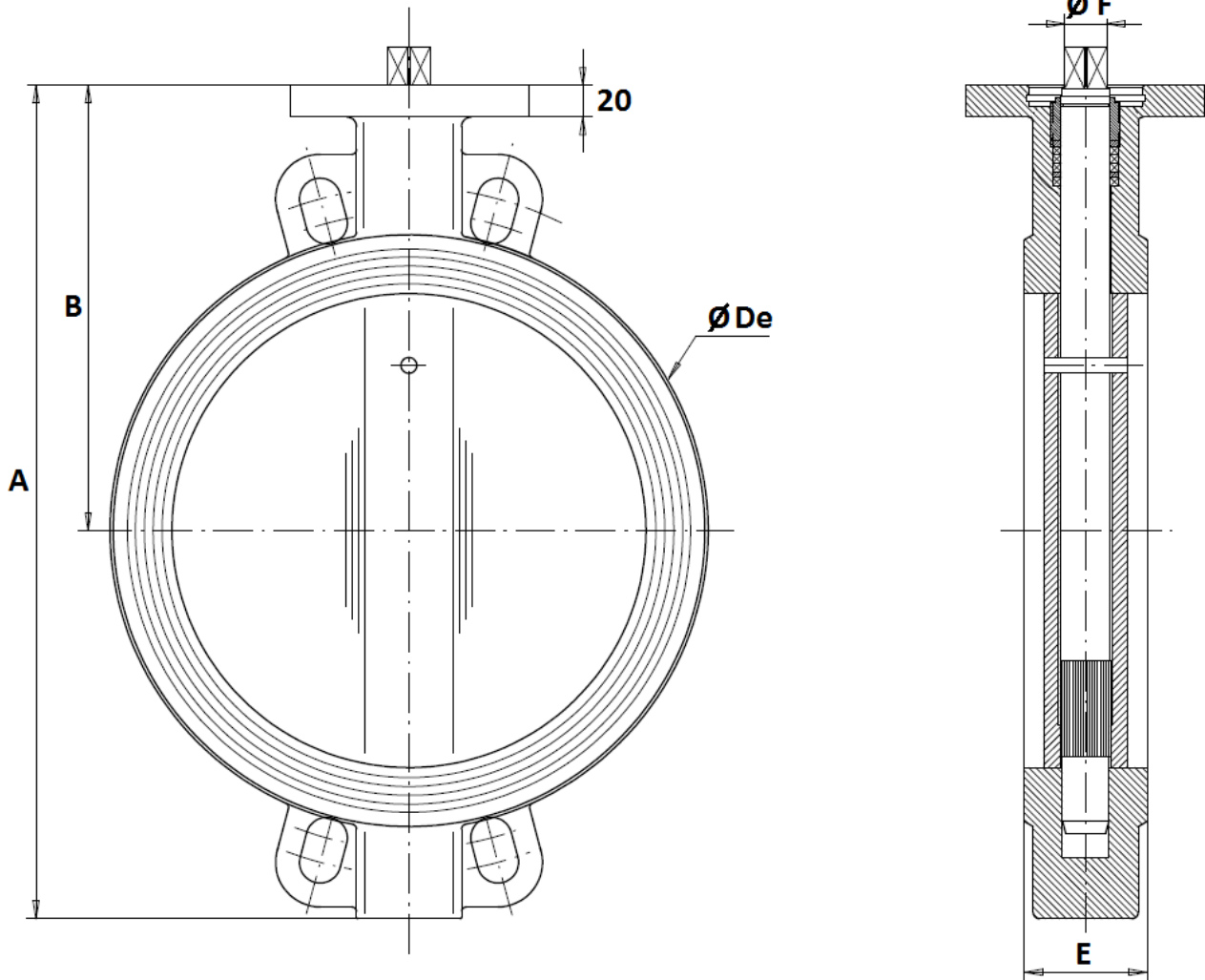

DN	250	300	350	400
A	461	524	570	644
B	248	280	300	340
Ø De	328	381	437	486
E	68	78	78	102
Ø F	23	26.5	26.5	33
Weight (Kg)	30	40	54	75

**METAL/METAL WAFER BUTTERFLY VALVE ( NO TIGHTNESS )  
EXCELLENCE RANGE**

STANDARD LEVERS SIZE ( in mm ) :

**DN 32 – 200 :**

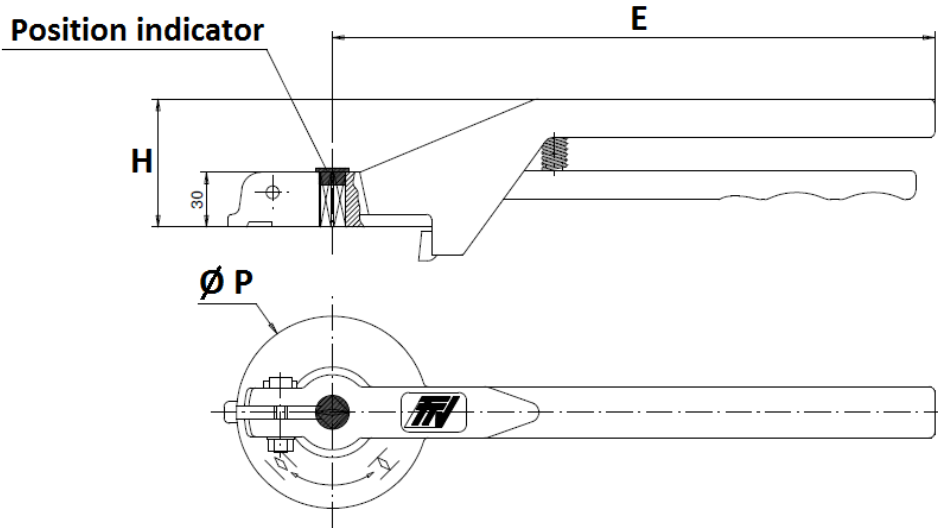

DN	32-100	125-200
E	205	330
H	57	70
Ø P	88	105

**DN 250 – 300 :**

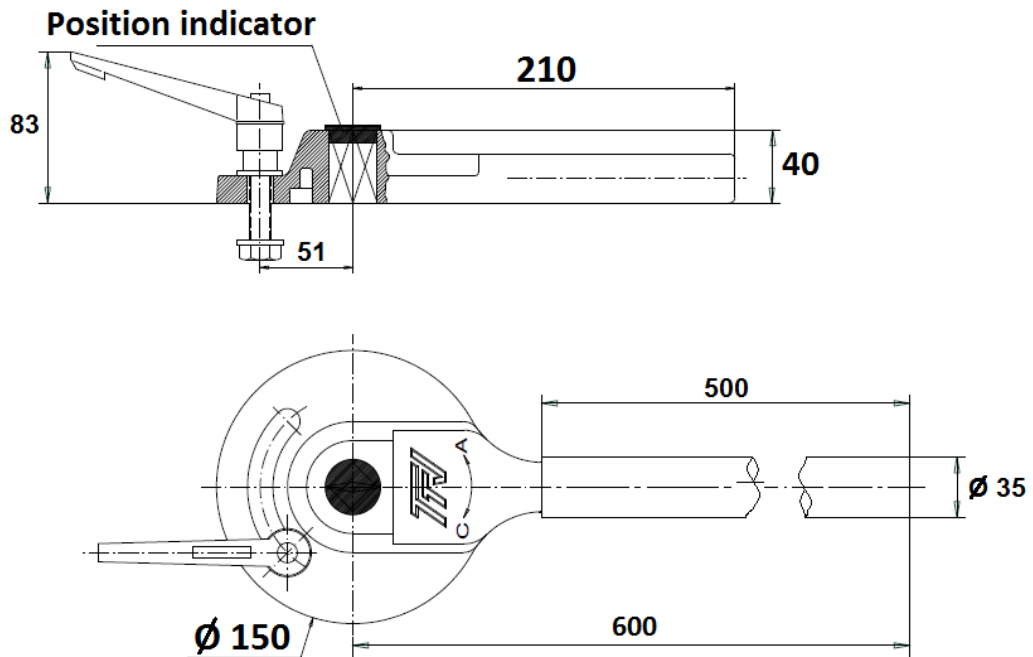

**METAL/METAL WAFER BUTTERFLY VALVE ( NO TIGHTNESS )  
EXCELLENCE RANGE**

**ASTM A351 CF8M STAINLESS STEEL LEVERS SIZE ( in mm ) ( ON REQUEST ) :**

**DN 40 - 100**

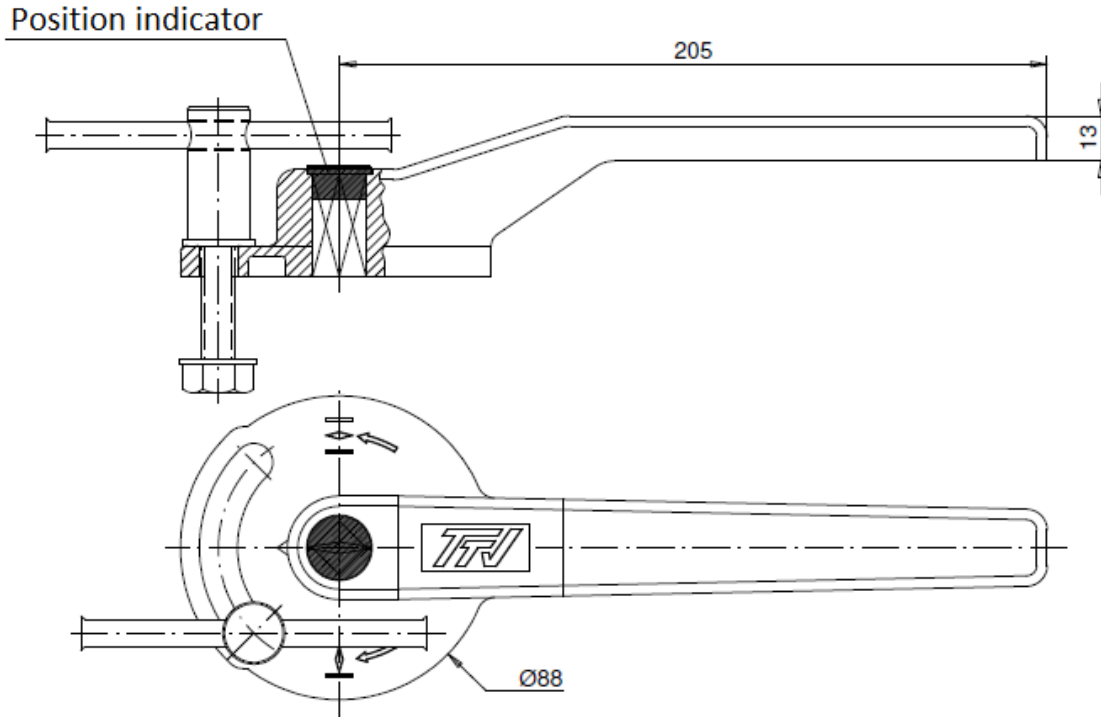

**DN 125 - 200**

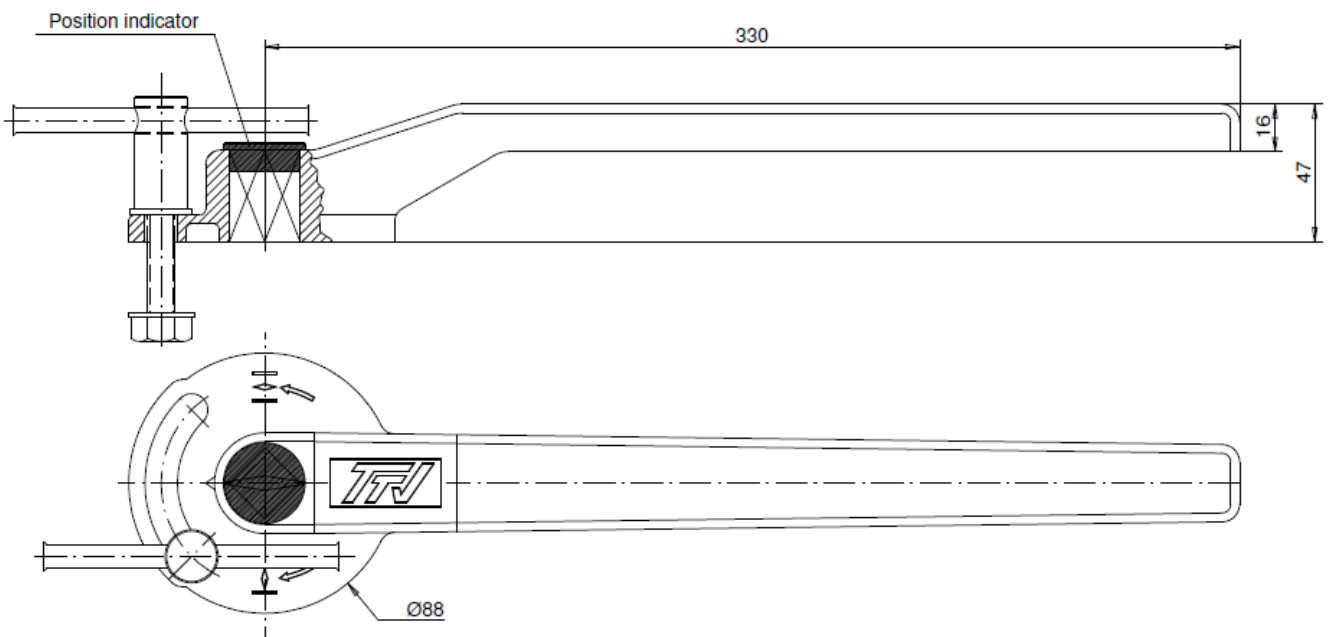

**METAL/METAL WAFER BUTTERFLY VALVE ( NO TIGHTNESS )  
EXCELLENCE RANGE**

SIZE ( in mm ) :

- Valves DN 450 - 1400 :

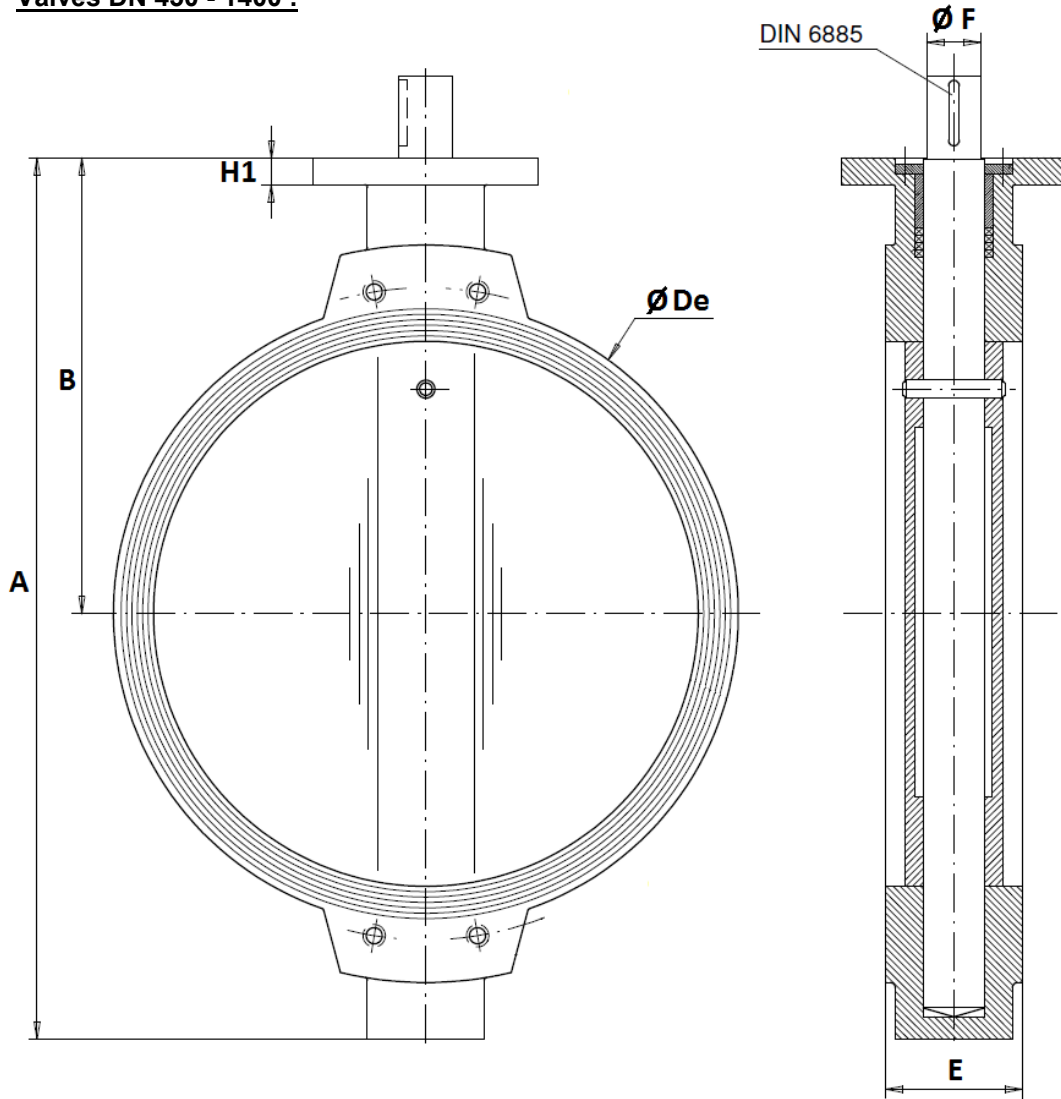

DN	450	500	600	700	750	800	900	1000	1100	1200	1300	1400
A	721	810	950	1085	1135	1233	1310	1442	1565	1706	1895	1975
B	390	440	507	575	600	655	685	754	815	873	1005	1025
Ø De	538	595	695	804	860	911	1010	1124	1225	1330	1460	1530
E	114	127	154	165	190	190	203	216	216	254	360	360
Ø F	50	50	60	60	65	65	80	80	80	100	120	120
Key (DIN6885)	14x9	14x9	18x11	18x11	20x12	20x12	22x14	22x14	22x14	28x16	32x18	32x18
H1	25	25	30	30	30	30	30	30	30	35	35	35
Weight (Kg)	87	117	177	258	296	330	505	661	840	1020	1650	1900

**METAL/METAL WAFER BUTTERFLY VALVE ( NO TIGHTNESS )  
EXCELLENCE RANGE**

ISO MOUNTING PAD AND STEM SIZE DN 40 - 400 ( in mm ) :

**DN 40 – 200**

**DN250 - 400**

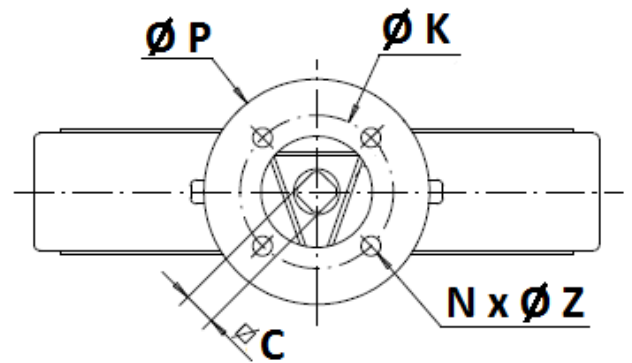
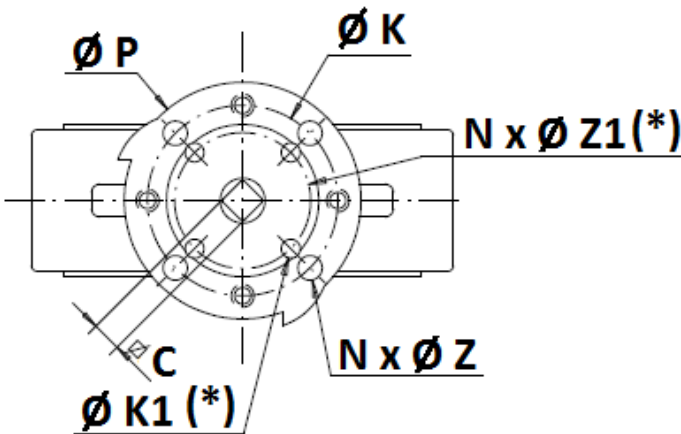
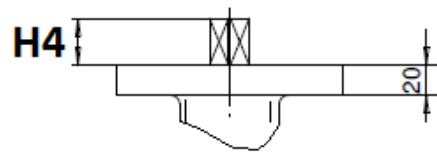
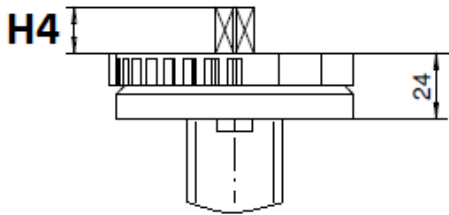

(\*) : Only from DN32 to DN100

DN	40	50	65	80	100	125	150	200	250	300	350	400
H4	14	14	16	16	20	20	20	24	24	24	29	29
C	8	8	9	11	11	14	14	17	19	22	22	27
Ø K	70	70	70	70	70	70	70	70	102	102	140	140
ISO	F07	F07	F07	F07	F07	F07	F07	F07	F10	F10	F14	F14
N x Ø Z	4 x 9	4 x 9	4 x 9	4 x 9	4 x 9	4 x 9	4 x 9	4 x 9	4 x 11	4 x 11	4 x 18	4 x 18
Ø K1	50	50	50	50	50	-	-	-	-	-	-	-
ISO 1	F05	F05	F05	F05	F05	-	-	-	-	-	-	-
N x Ø Z1	4 x 7	4 x 7	4 x 7	4 x 7	4 x 7	-	-	-	-	-	-	-

**METAL/METAL WAFER BUTTERFLY VALVE ( NO TIGHTNESS )  
EXCELLENCE RANGE**

ISO MOUNTING PAD AND STEM SIZE DN450-1400 ( in mm ) :

**DN 450 - 1400**

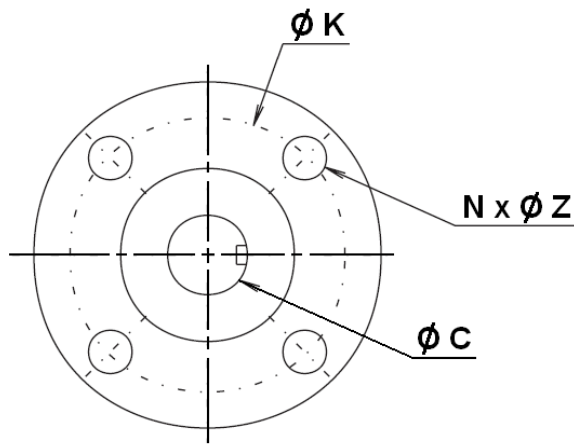
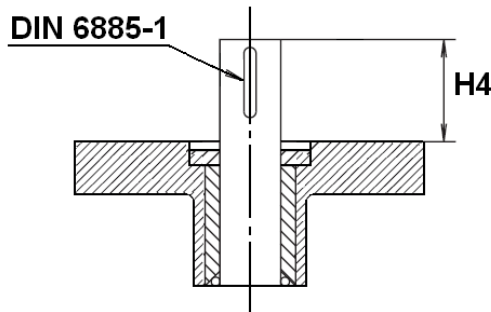

DN	450	500	600	700	750	800	900	1000	1100	1200	1300	1400
H4	80	80	90	90	110	110	110	110	110	110	120	120
Ø C	50	50	60	60	65	65	80	80	80	100	120	120
Ø K	140	140	165	254	254	254	254	254	254	254	298	298
ISO	F14	F14	F16	F25	F25	F25	F25	F25	F25	F25	F30	F30
N x Ø Z	4 x 18	4 x 18	4 x 22	8 x 18	8 x 18	8 x 18	8 x 18	8 x 18	8 x 18	8 x 18	8 x 22	8 x 22

**METAL/METAL WAFER BUTTERFLY VALVE ( NO TIGHTNESS )  
EXCELLENCE RANGE**

SIZE ( in mm ) :

- Valves with gear box DN 40 - 400 :

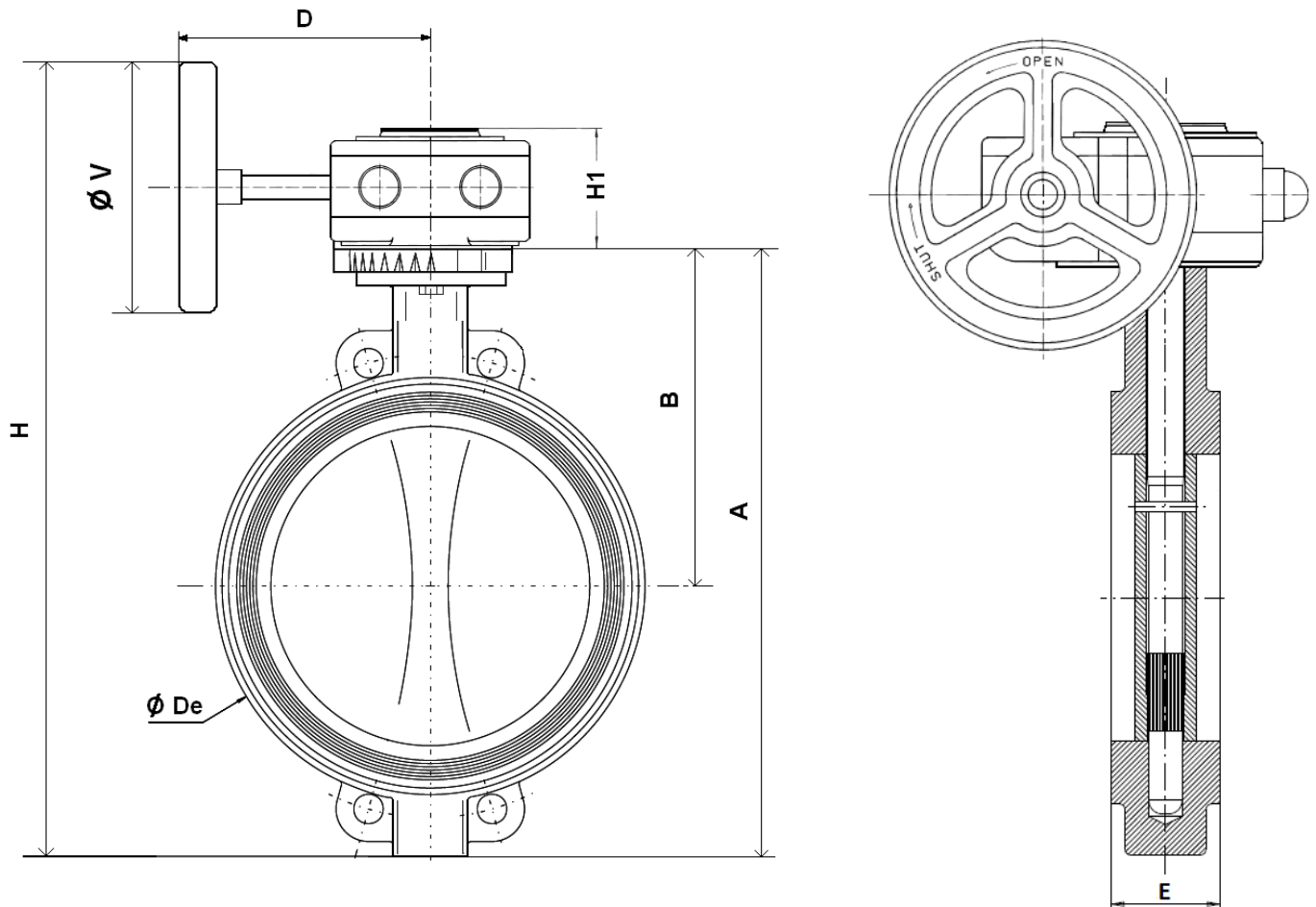

DN	40	50	65	80	100	125	150	200	250	300	350	400
A	205	228	248	265	298	331	349	430	461	524	570	644
B	140	156	161	169	187	206	215	255	248	280	300	340
Ø De	82	102	119	135	155	185	208	270	328	381	437	486
D	120	120	120	120	120	136	136	136	223	223	345	345
E	33	43	46	46	52	56	56	60	68	78	78	102
H	304	326	341	364	392	452	477	566	647	709	831	894
H1	58	58	58	58	58	58	58	58	74	74	98	98
Ø V	140	140	140	140	140	200	200	200	300	300	400	400
Weight (Kg)	4.42	6.92	6.24	7.3	8.93	11.97	13.98	20.75	34	44	63.5	84.5

**METAL/METAL WAFER BUTTERFLY VALVE ( NO TIGHTNESS )  
EXCELLENCE RANGE**

SIZE ( in mm ) :

- Valves with gear box DN 450 - 1400 :

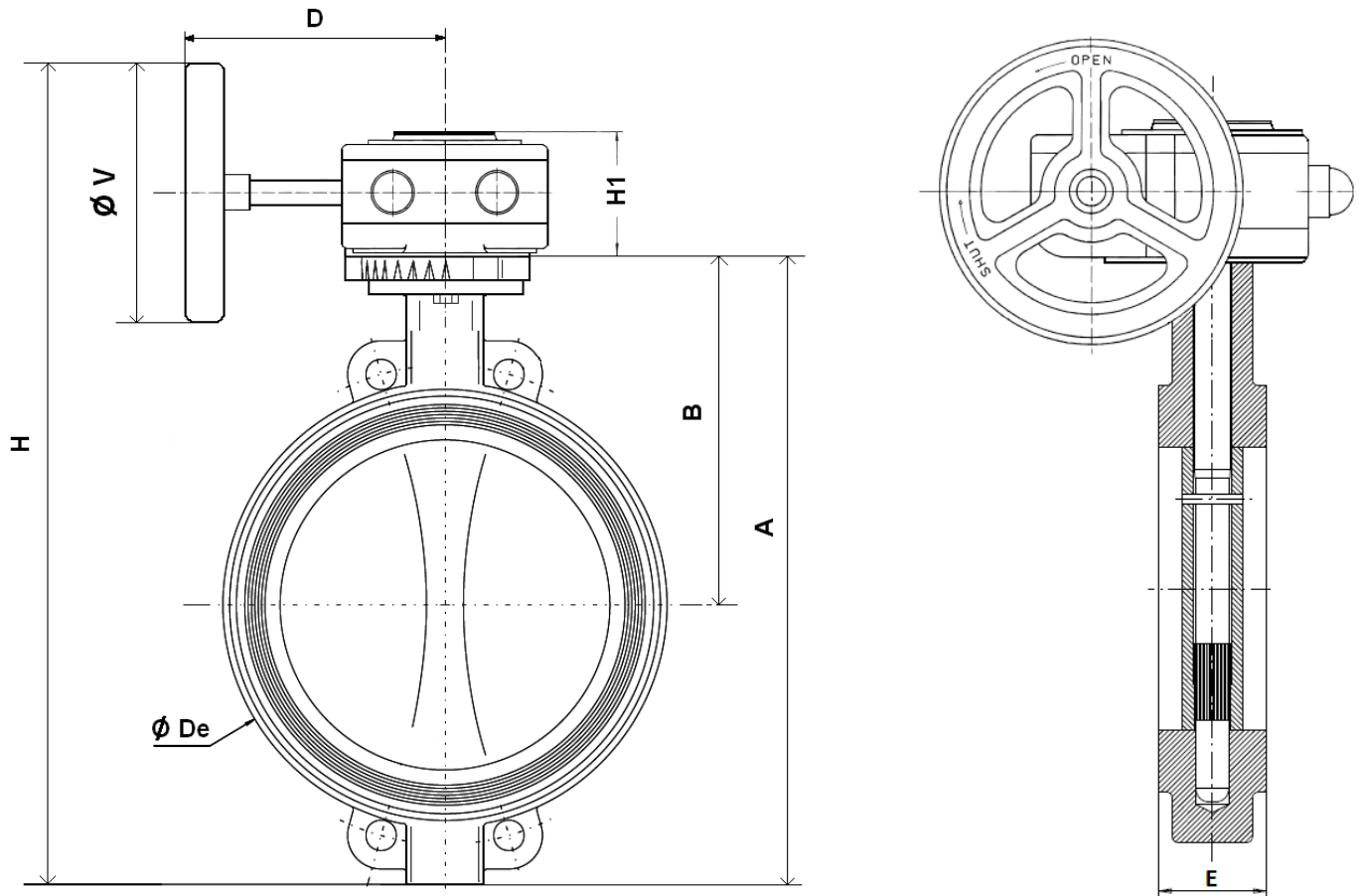

DN	450	500	600	700	750	800	900	1000	1100	1200	1300	1400
A	721	810	950	1085	1135	1233	1310	1442	1565	1706	1895	1975
B	390	440	507	575	600	655	685	754	815	873	1005	1025
Ø De	538	595	695	804	860	911	1010	1124	1225	1330	1460	1530
D	364	386	421	440	440	438	492	492	492	550	605	605
E	114	127	154	165	190	190	203	216	216	254	360	360
H	1083	1171	1376	1409	1459	1657	1688	1820	1943	2178	2260	2429
H1	90	98	122	117	117	117	125	125	125	115	178	178
Ø V	600	600	700	500	500	700	600	600	600	800	700	700
Weight (Kg)	135.8	179.8	278.3	376	430	480.3	710.8	909.8	1124.8	1391.5	2243	2552



**METAL/METAL WAFER BUTTERFLY VALVE ( NO TIGHTNESS )  
EXCELLENCE RANGE**

SIZE ( in mm ) :

- Valves with chain gear box :

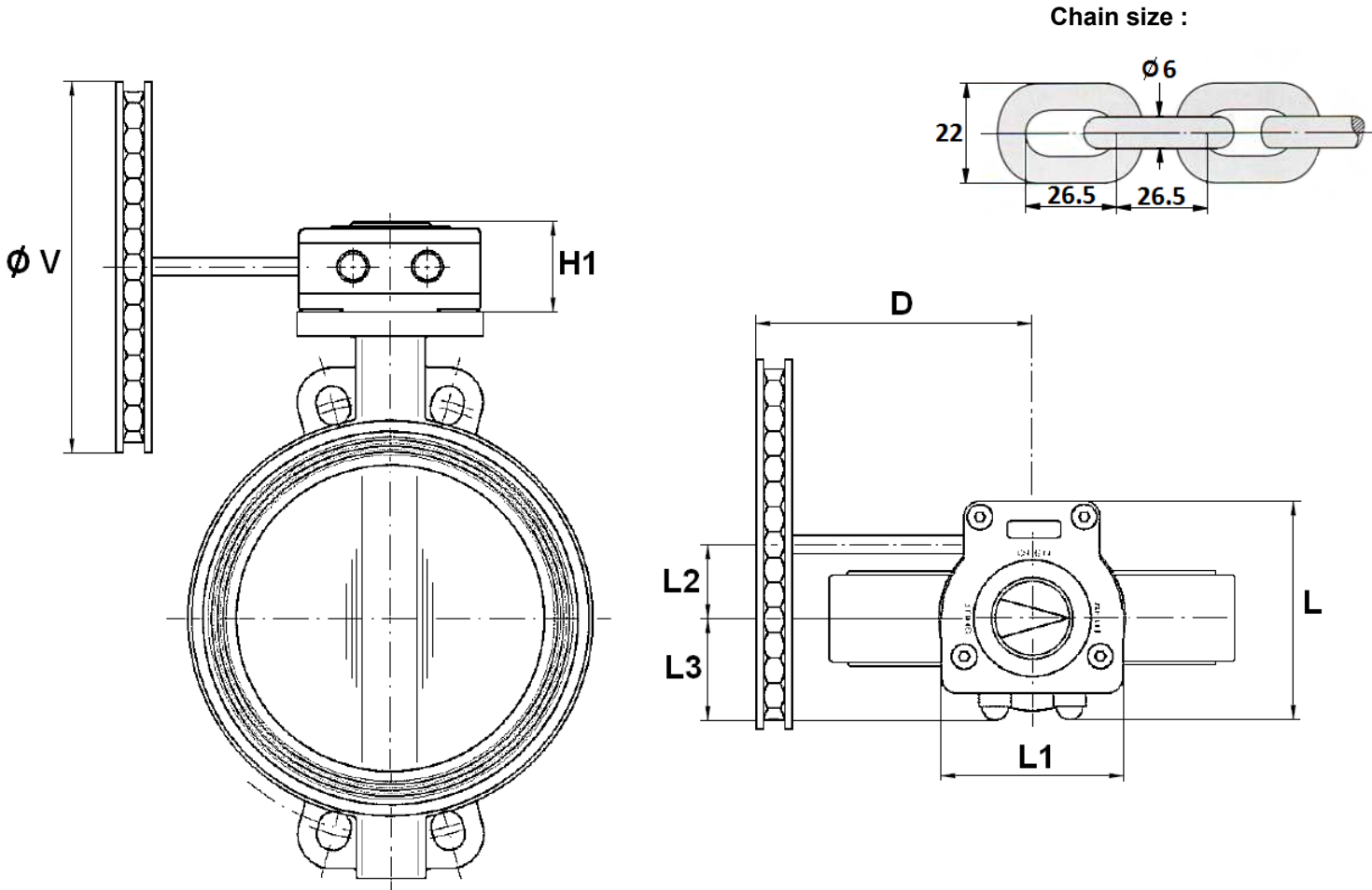

DN	40	50	65	80	100	125	150	200	250	300	350	400	450	500
D	120	120	120	120	120	126	126	126	214	214	331	331	350	365
H1	58	58	58	58	58	58	58	58	74	74	98	98	90	98
L	128	128	128	128	128	128	128	128	175	175	224	224	232	267
L1	100	100	100	100	100	100	100	100	142	142	185	185	204	227
L2	50	50	50	50	50	50	50	50	61	61	80	80	86	104.5
L3	56	56	56	56	56	56	56	56	80	80	98	98	100	110
Ø V	160	160	160	160	160	210	210	210	300	300	400	400	500	500
Weight (Kg)	5.42	6.92	7.24	8.3	9.93	12.97	14.98	21.75	36.8	46.8	68.3	89.3	143.2	186.7

**METAL/METAL WAFER BUTTERFLY VALVE ( NO TIGHTNESS )  
EXCELLENCE RANGE**

**GEARBOX SPECIFICATIONS :**

DN	32/50	65	80/100	125/150	200	250	300	350
Ref.	1197050	1197065	1197100	1197150	1197200	1197250	1197300	1197350
Ratio factor	37 : 1	37 : 1	37 : 1	37 : 1	37 : 1	36 : 1	36 : 1	50 : 1
Number of cycles for opening or closing	9.25	9.25	9.25	9.25	9.25	9	9	12.5
Input torque ( Nm )	12.5	12.5	12.5	12.5	12.5	23	23	50
Output torque ( Nm )	300	300	300	300	300	675	675	1310

DN	400	450	500	600	700	800	900	1000
Ref.	1197400	1197451	1197501	1197601	1197700	1197800	-	-
Ratio factor	50 : 1	38 : 1	55 : 1	52 : 1	208 : 1	208 : 1	312 : 1	312 : 1
Number of cycles for opening or closing	12.5	9.5	13.75	13	52	52	78	78
Input torque ( Nm )	50	86	96	160	65	65	80	80
Output torque ( Nm )	1310	1620	2640	4160	6800	6800	12500	12500

DN	1200	1300	1400
Ratio factor	702 : 1	720 : 1	720 : 1
Number of cycles for opening or closing	175.5	180	180
Input torque ( Nm )	50	91	91
Output torque ( Nm )	17000	32000	32000

**METAL/METAL WAFER BUTTERFLY VALVE ( NO TIGHTNESS )  
EXCELLENCE RANGE**

**BETWEEN FLANGES SIZE ( in mm ) :**

**DN 32-200**

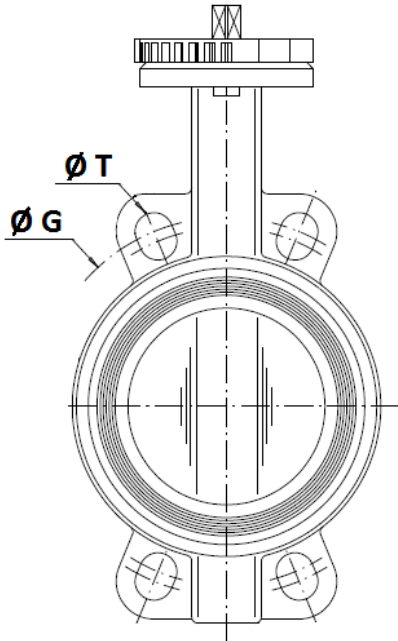

**DN250 – 400**

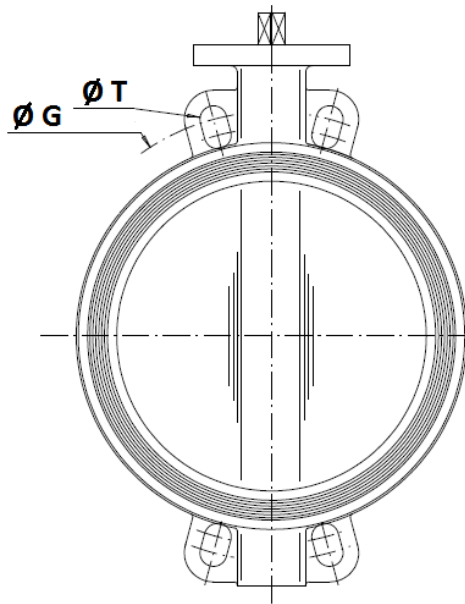

**DN450-1400**

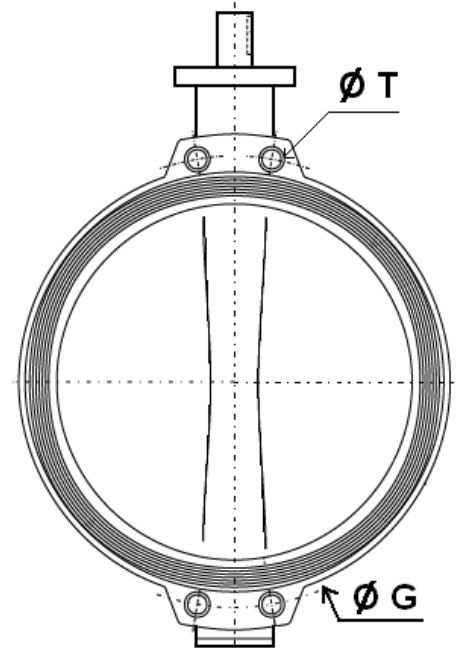

	DN (mm)	32	40	50	65	80	100	125	150	200	250	300	350	400
	NPS ( " )	1"1/4	1"1/2	2"	2"1/2	3"	4"	5"	6"	8"	10"	12"	14"	16"
PN10	Ø G	100	110	125	145	160	180	210	240	295	350	400	460	515
	Ø T	18	18	18	18	18	18	18	23	23	23	23	23	27
PN16	Ø G	100	110	125	145	160	180	210	240	295	355	410	470	525
	Ø T	18	18	18	18	18	18	18	23	23	27	27	27	30
Class 150	Ø G	88.9	98.5	120.6	139.7	152.4	190.5	215.9	241.3	298.5	362	431.8	476.3	539.8
	Ø T	16	16	19	19	19	19	23	23	23	26	26	29	29

	DN (mm)	450	500	600	700	750	800	900	1000	1100	1200	1300	1400
	NPS ( " )	18"	20"	24"	28"	30"	32"	36"	40"	44"	48"	52"	56"
PN10	Ø G	565	620	725	840	900	950	1050	1160	1270	1380	-	1590
	Ø T	M24	M24	M27	M27	M30	M30	M30	M33	M33	M36	-	M39
PN16	Ø G	585	650	770	840	900	950	1050	1170	1270	1390	-	1590
	Ø T	M27	M30	M33	M33	M33	M36	M36	M39	M39	M45	-	M45
Class 150	Ø G	577.9	635	749.3	863	914	978	1086	1200	1314	1422	1537	1651
	Ø T (BSW)*	1 1/8"	1 1/8"	1 1/4"	1 1/4"	1 1/4"	1 1/2"	1 1/2"	1 1/2"	1 1/2"	1 1/2"	1 3/4"	1 3/4"
	Ø T (Metric)	M30	M30	M33	M33	M33	M39	M39	M39	M39	M39		

\* Threaded BSW on standard, on request metric threaded for Class 150

**METAL/METAL WAFER BUTTERFLY VALVE ( NO TIGHTNESS )  
EXCELLENCE RANGE**

NECK AND DISC SIZE ( in mm ) :

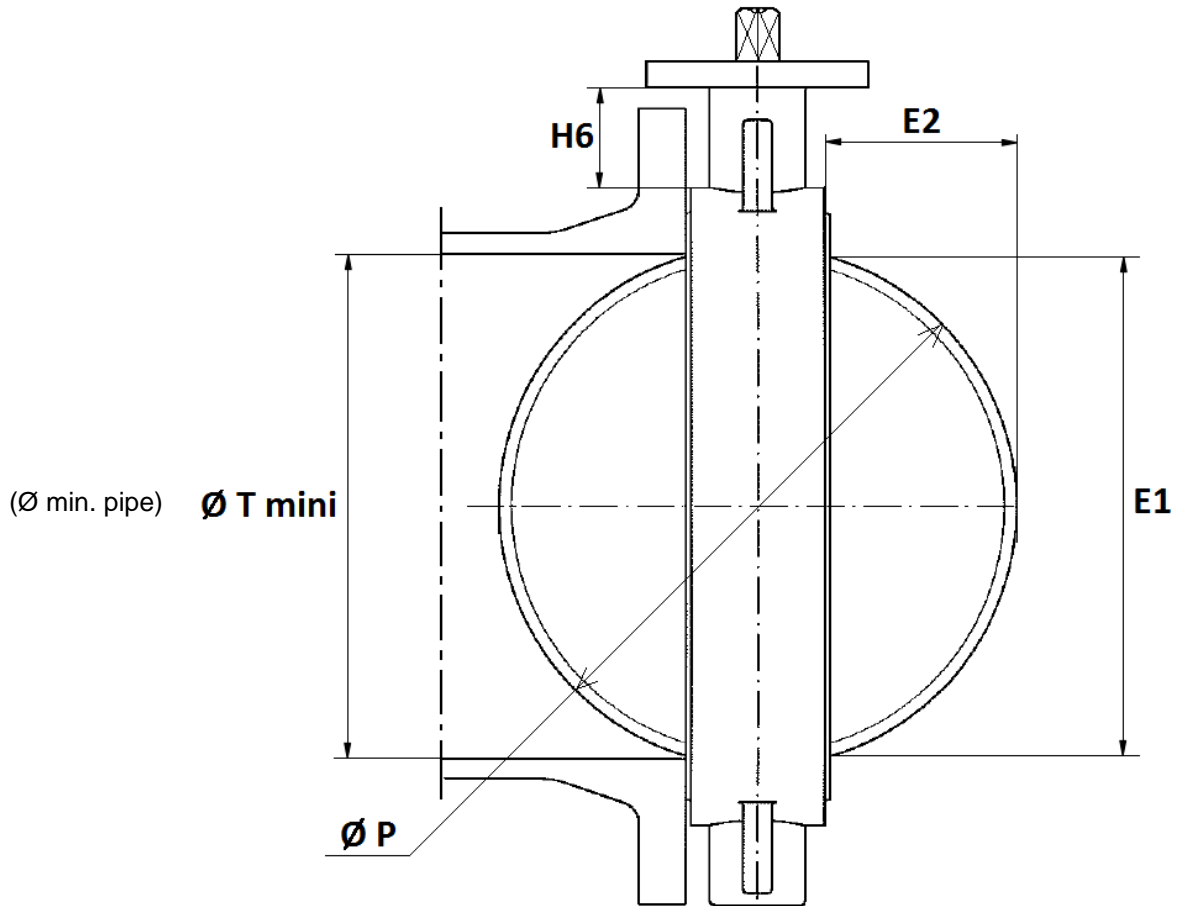

DN	32/40	50	65	80	100	125	150	200	250	300	350	400	450	500	600
E1	23	24.5	46	65	85	109	136	188	238	289	331	385	424	479	575
E2	3.5	3.5	9.5	17	24	33.5	45.5	69	90	110.5	131	148	162.5	184	221
H6	76	82	80	80	88	93	89	99	71	76	69	80	96	119	127
Ø T mini	26	27.5	49	68	88	112	139	191	241	292	334	388	427	482	578
Ø P	40	50	65	80	100	123	147	198	248	299	340	398	439	495	596

DN	700	750	800	900	1000	1100	1200	1300	1400
E1	680	721	777	850	957	1052	1146	1261	1368
E2	267.5	278	305	335.5	382.5	429	460	475.5	527.5
H6	148	140	170	150	162	175	176	240	228
Ø T mini	683	724	780	853	960	1055	1149	1264	1371
Ø P	700	746	800	874	981	1074	1174	1311	1415

**METAL/METAL WAFER BUTTERFLY VALVE ( NO TIGHTNESS )  
EXCELLENCE RANGE**

**SIZE ( in mm ) :**

- **Square lever for special key ( 30x30 mm ) :**

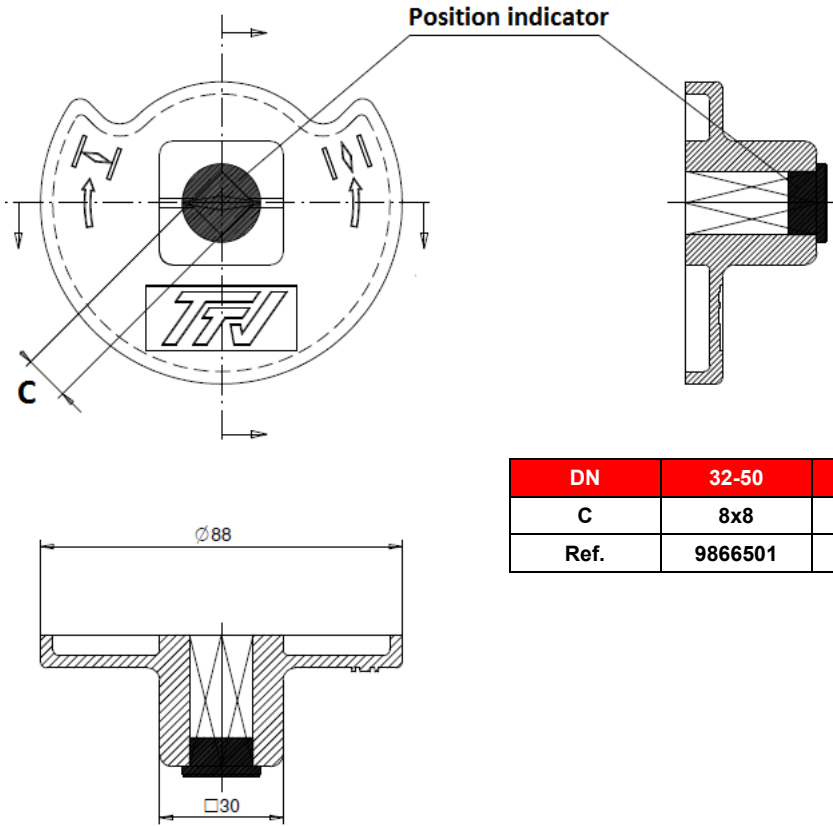

DN	32-50	65	80-100	125-150	200
C	8x8	9x9	11x11	14x14	17x17
Ref.	9866501	9866502	9866503	9866504	9866505

**METAL/METAL WAFER BUTTERFLY VALVE ( NO TIGHTNESS )  
EXCELLENCE RANGE**

**STANDARDS :**

- Fabrication according to ISO 9001:2015
- Designing according to ISO 10631 and EN 593
- DIRECTIVE 2014/68/EU : CE N° 0038  
Risk Category III module H
- Certificate 3.1 on request
- **Body tests** according to EN 12266-1, Rate A
- Between flanges according to EN 1092-1 PN10/16
- ISO 5211 mounting pad
- Length according to ISO 5752 short series 20, EN 558 series 20 ( NF 29305 ), BS 5155 Wafer short/medium, DIN 3202 part 3, series K1
- ATEX Group II Category 2 G/2D Zone 1 & 21 Zone 2 & 22 ( optional marking )
- Approval certificate **Marine BUREAU VERITAS**, N° 14087/C0 BV from DN32 to 1000 on request
- OTAN agreement ( N° 286B )

**ADVICE :** Our opinion and our advice are not guaranteed and Lauridsen Group shall not be liable for the consequences of damages. The customer must check the right choice of the products with the real service conditions.

**METAL/METAL WAFER BUTTERFLY VALVE ( NO TIGHTNESS )  
EXCELLENCE RANGE**

**INSTALLATION INSTRUCTIONS**

**GENERAL GUIDELINES :**

- Ensure that the valves to be used are appropriate for the conditions of the installation (type of fluid, pressure and temperature).
- Be sure to have enough valves to be able to isolate the sections of piping as well as the appropriate equipment for maintenance and repair.
- Ensure that the valves to be installed are of correct strength to be able to support the capacity of their usage.
- **Installation of all circuits should ensure that their function can be automatically tested on a regular basis (at least two times a year).**

**INSTALLATION INSTRUCTIONS :**

- **Before installing the valves, clean and remove any objects from the pipes** (in particular bits of sealing and metal) which could obstruct and block the valves.
- **Ensure that both connecting pipes either side of the valve (upstream and downstream) are aligned (if they're not, the valves may not work correctly).**
- **Make sure that the two sections of the pipe (upstream and downstream) match, the valve unit will not absorb any gaps. Any distortions in the pipes may affect the tightness of the connection, the working of the valve and can even cause a rupture.** To be sure, place the kit in position to ensure the assembling will work.
- **If sections of piping do not have their final support in place, they should be temporarily fixed. This is to avoid unnecessary strain on the valve.**
- Tighten the bolts in cross.
- The disc must move easily inside the pipe.
- Valves must be opened during cleaning operation.
- Tests must be done with a cleaned pipe.
- Tests must be done with opened valve. Test pressure must not be higher than the valve specification according to EN 12266-1.
- Then open slowly the valve.
- **Do not mount butterfly valves with stainless steel pressed collars and turning flanges without strias.**
- **And not on flat face flanges without strias ( example : painted cast iron fittings )**

**METAL/METAL WAFER BUTTERFLY VALVE ( NO TIGHTNESS )  
EXCELLENCE RANGE**

**MAXIMUM TIGHTENING TORQUES FOR BOLTING FLANGES :**

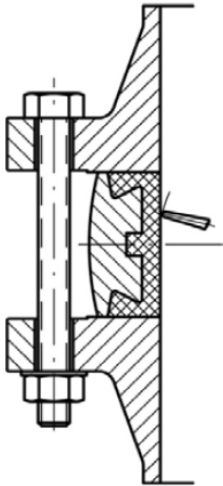

		Maximum torques (Nm)			
		Bolting types	5,6 / A307 Gr.B	8,8 / A193 B7	10,9
<b>Bolting DN</b>	<b>M12 (1/2")</b>	41,16	84,28	117,6	142,1
	<b>M14 (9/16")</b>	66,64	132,3	186,2	225,4
	<b>M16 (5/8")</b>	102,9	205,8	289,1	347,9
	<b>M18 (3/4")</b>	142,1	284,2	396,9	475,3
	<b>M20 (3/4")</b>	196	401,8	568,4	676,2
	<b>M22 (7/8")</b>	259,7	539	764,4	911,4
	<b>M24 (1")</b>	338,1	695,8	980	1176
	<b>M27 (1"1/8)</b>	499,8	1029	1470	1764
	<b>M30 (1"1/4)</b>	666,4	1421	1960	2352

**BEST POSITION INSTALLATION :**

For wastewater, fluids with solid particles or cold network (air conditioning for example), the best position is the horizontal one :



**MAINTENANCE :**

- We recommend to operate fully the valve 1 to 2 times per year.
- During maintenance operation, ensure that the pipe isn't under pressure, that there's no fluid in the pipe and that the valve is isolated. If there's a fluid in the pipe , evacuate it. Ensure that there are no risks due to the temperature or the fluid ( like acids ). If the fluid is corrosive , inert the installation before maintenance operation.