

FORGED CARBON STEEL A350LF2 GLOBE VALVE CLASS 1500 TRIM 12 BOLTED BONNET



ISO 9001 : 2015



PED 2014/68/EU



Certificate 3.1

Size : DN 15 to 50 (NPS 1/2" to 2")
Ends : Female - Female NPT, Socket Welding
Min Temperature : - 46°C
Max Temperature : + 425°C
Max Pressure : 255 Bars (Class 1500)
Specifications : Rising rotating stem (OS&Y)
Bolted bonnet
Standard bore

Materials : Forged carbon steel A350 LF2

FORGED CARBON STEEL A350LF2 GLOBE VALVE CLASS 1500 TRIM 12 BOLTED BONNET

SPECIFICATIONS :

- Respect the flow direction (indicated by the arrow)
- Standard bore
- Rising rotating stem (OS&Y)
- Bolted bonnet
- Bolted gland pack
- Forged carbon steel ASTM A350 LF2
- 1/2 stellite (Trim 12)
- Class 1500

USE :

- Petroleum industry, steam, high pressure
- Min and max Temperature Ts : - 46°C to + 425°C
- Max Pressure Ps : 255 bars (see graph)

FLOW COEFFICIENT Kvs (M3 / h) :

| DN | 15 | 20 | 25 | 32 | 40 | 50 |
|--------------|------|------|-----|-------|-------|------|
| NPS | 1/2" | 3/4" | 1" | 1"1/4 | 1"1/2 | 2" |
| Kvs (m3/h) | 1.3 | 3.3 | 5.9 | 9.5 | 12.4 | 21.6 |

PRESSURE / TEMPERATURE RELATION :

| Pressure (bar) | 255.3 | 255.3 | 255.3 | 250.4 | 231.9 | 226.1 | 219.1 | 208.6 | 193.7 | 184.8 | 182.3 | 172.5 | 143.8 |
|------------------|-------|-------|-------|-------|-------|-------|-------|-------|-------|-------|-------|-------|-------|
| Temperature (°C) | -46 | 0 | 38 | 50 | 100 | 150 | 200 | 250 | 300 | 350 | 375 | 400 | 425 |

PRESSURE / TEMPERATURE GRAPH :

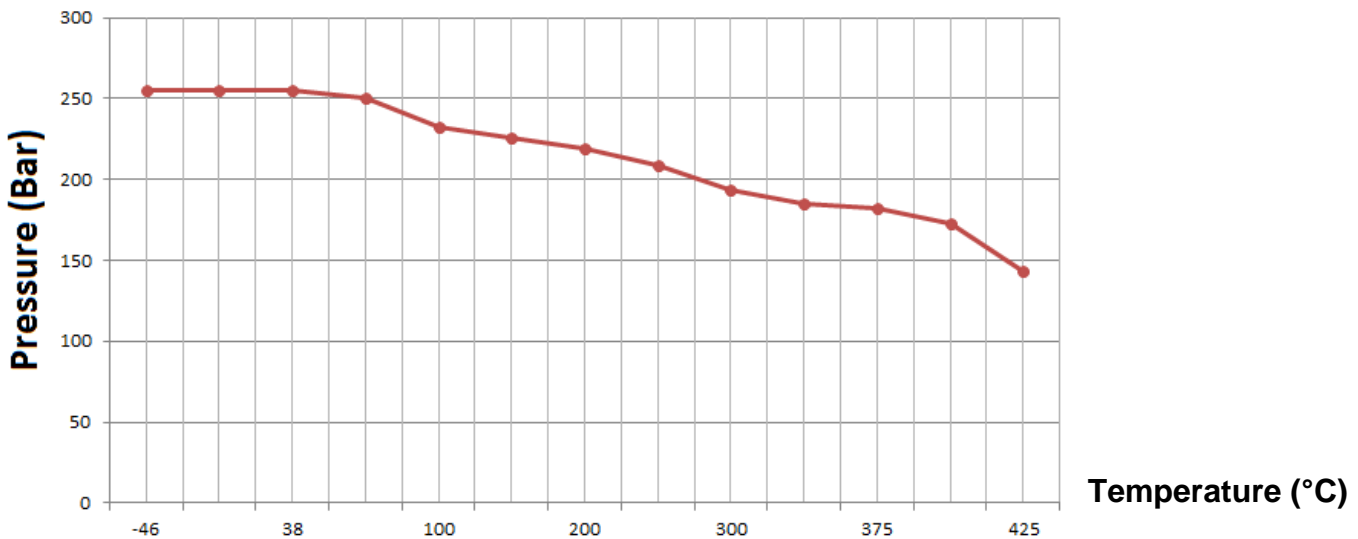

FORGED CARBON STEEL A350LF2 GLOBE VALVE CLASS 1500 TRIM 12 BOLTED BONNET

RANGE :

- Forged globe valve A350LF2 with threaded NPT ends **Ref.420** from DN 15 to 50 (NPS 1/2" to 2")
- Forged globe valve A350LF2 with Socket Welding ends **Ref.421** from DN 15 to 50 (NPS 1/2" to 2")

MATERIALS :

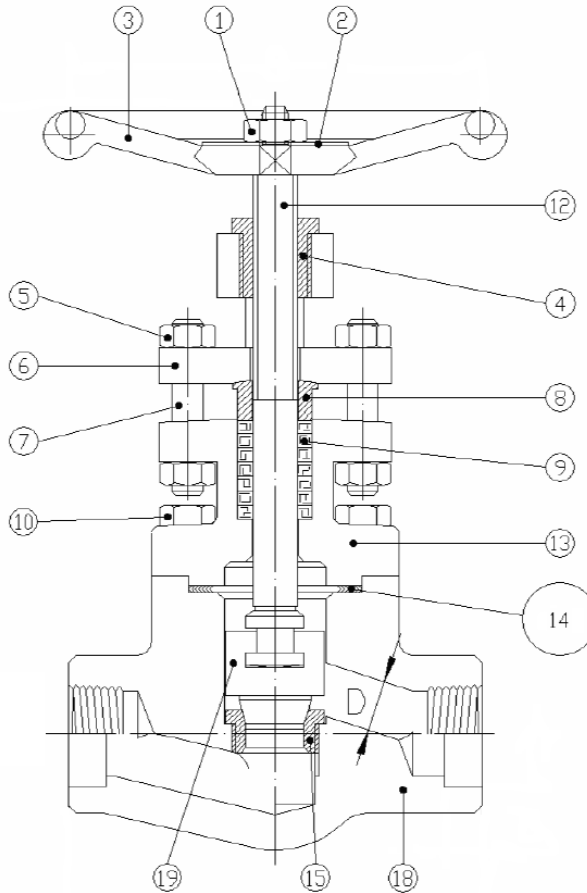

| Item | Designation | Materials |
|------|---------------|----------------------------------|
| 1 | Handwheel nut | Carbon steel |
| 2 | ID plate | Aluminium |
| 3 | Handwheel | Carbon steel |
| 4 | Yoke nut | ASTM A473 type 416 |
| 5 | Gland nut | ASTM A194 Gr.4 |
| 6 | Gland flange | ASTM A182 F6a CI 2 |
| 7 | Gland stud | ASTM A320 L7 |
| 8 | Gland | UNS S31600/S31603 |
| 9 | Packing | Graphite |
| 10 | Screw | ASTM A320 L7 |
| 12 | Stem | ASTM A479 316/316L |
| 13 | Bonnet | ASTM A350 LF2 |
| 14 | Gasket | SS 316 + graphite spiral |
| 15 | Seat | ASTM A479 S31600/S31603 Stellite |
| 18 | Body | ASTM A350 LF2 |
| 19 | Disc | ASTM A182 316/316L |

FORGED CARBON STEEL A350LF2 GLOBE VALVE CLASS 1500 TRIM 12 BOLTED BONNET

SIZE (in mm) :

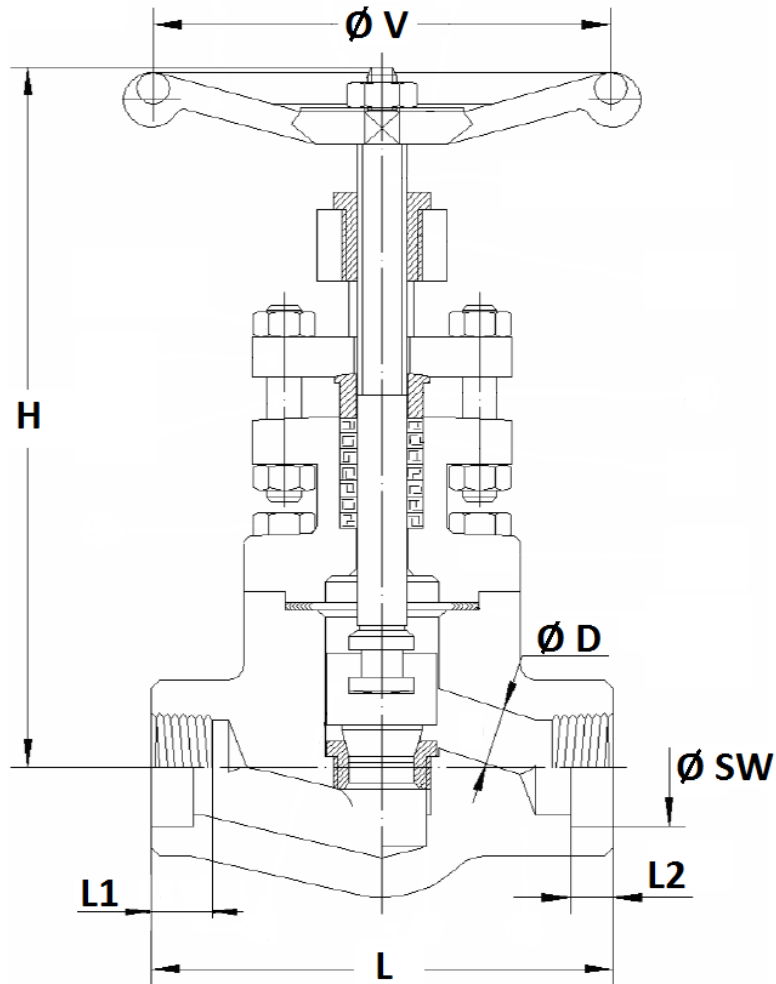

| Ref. | DN (mm) | 15 | 20 | 25 | 40 | 50 |
|---------|----------------|------|------|------|--------|------|
| | NPS (") | 1/2" | 3/4" | 1" | 1"1/2" | 2" |
| 420/421 | Ø D | 9 | 13 | 17 | 28 | 35 |
| | L | 90 | 110 | 127 | 170 | 210 |
| | H (opened) | 160 | 175 | 210 | 250 | 360 |
| | Ø V | 80 | 110 | 130 | 180 | 180 |
| 420 | L1 | 15 | 18 | 19 | 21 | 21 |
| 421 | L2 (SW) | 12.7 | 14.5 | 16 | 19 | 22 |
| | Ø SW | 21.8 | 27.2 | 33.9 | 48.8 | 61.2 |
| 420/421 | Weight (in Kg) | 2.2 | 3.8 | 5.9 | 12 | 23 |

FORGED CARBON STEEL A350LF2 GLOBE VALVE CLASS 1500 TRIM 12 BOLTED BONNET

STANDARDS :

- Fabrication according to **ISO 9001 : 2015**
- **DIRECTIVE 2014/68/EU : CE N° 0036**
Risk category III module H
- Certificate 3.1 on request
- Designing according to **ISO 15761** and **API 602** 8th
- Pressure Tests according to **API 598, table 6**
- Valves approved by the main oil industries (certificates on request)
- **ATEX Group II Category 2 GD T3 Zone 1 & 21 Zone 2 & 22** (optional marking) according to directive 2014/34/EU
- Threaded female NPT ends according to **ANSI B1.20.1**
- Socket Welding ends according to **ISO 15761**

ADVICE : Our opinion and our advice are not guaranteed and Lauridsen Group shall not be liable for the consequences of damages. The customer must check the right choice of the products with the real service conditions.

FORGED CARBON STEEL A350LF2 GLOBE VALVE CLASS 1500 TRIM 12 BOLTED BONNET

INSTALLATION INSTRUCTIONS**GENERAL GUIDELINES :**

- Ensure that the valves to be used are appropriate for the conditions of the installation (type of fluid, pressure and temperature).
- Be sure to have enough valves to be able to isolate the sections of piping as well as the appropriate equipment for maintenance and repair.
- Ensure that the valves to be installed are of correct strength to be able to support the capacity of their usage.
- **Installation of all circuits should ensure that their function can be automatically tested on a regular basis (at least two times a year).**

INSTALLATION INSTRUCTIONS :

- **Before installing the valves, clean and remove any objects from the pipes** (in particular bits of sealing and metal) which could obstruct and block the valves.
- **Ensure that both connecting pipes either side of the valve (upstream and downstream) are aligned (if they're not, the valves may not work correctly).**
- **Make sure that the two sections of the pipe (upstream and downstream) match, the valve unit will not absorb any gaps. Any distortions in the pipes may affect the tightness of the connection, the working of the valve and can even cause a rupture.** To be sure, place the kit in position to ensure the assembling will work.
- **During welding operation, for S.W. types half open the valve and do not exceed 350-400°C**
- The theoretical lengths given by ISO/R7 for the tapping are typically longer than required, the length of the thread should be limited, and **check that the end of the tube does not press right up to the head of the thread.**
- **Never use a vice to tighten the fixings of the valve.**
- **If sections of piping do not have their final support in place, they should be temporarily fixed. This is to avoid unnecessary strain on the valve.**
- **It may be necessary to screw the packing gland during using according to the type of use.**
- **Do not use a tool to shut the valve**
- **Fluids in the valve must not contain solid objects (it could damaged the seat).**
- It's recommended to operate the valve (open and close) 1 to 2 times per year