

CARBON STEEL SWING CHECK VALVE FLANGED CLASS 150 PN20 TRIM8

Carbon steel swing check valve TRIM8 flanged Class 150 PN20 full bore and partial opening for water distribution, gas oil, steam, petrochemical, petroleum industry and gas.

Bolting bonnet with hoisting eye from DN150 to 400.

Gasket bonnet in stainless steel + graphite.

Vertical or horizontal position

Compatible with explosive atmosphere, ATEX Zone 1&21 and Zone 2&22.



PED 2014/68/UE



Size : DN50 to DN400 (NPS 2" to 16")

Connection : Flanges RF Class 150 PN20

Min Temperature : -29°C

Max Temperature : +425°C

Max Pressure : 20 Bars

Specifications : TRIM8

Bolted bonnet

Full bore and partial opening

Materials : Carbon steel ASTM A216 WCB

CARBON STEEL SWING CHECK VALVE FLANGED CLASS 150 PN20 TRIM8

SPECIFICATIONS :

- Swing check valve
- Full bore and partial opening
- Vertical position with ascendant fluid or horizontal position (respect the flow direction indicated by the arrow)
- Flanges R.F. Class 150 (PN20)
- Carbon steel body
- Bolted bonnet
- Hoisting eye from DN150 to 400 (NPS 6" to 16")
- ½ stellite (Trim 8 , seat with stellite)
- Grey painting RAL 7001 color, 60 µm thickness

USE :

- Water distribution, gas oil, petrochemical, petroleum industry
- Min and max Temperature Ts : - 29°C to + 425°C
- Max Pressure Ps : 20 bars

FLOW COEFFICIENT Kvs :

DN (mm)	50	80	100	125	150	200	250	300	350	400
NPS (")	2"	3"	4"	5"	6"	8"	10"	12"	14"	16"
Kvs	40.7	92.9	169.6	265	381.5	685	1076.8	1556.7	1891	2515

PRESSURE / TEMPERATURE RELATION :

(According to AMSE B16-34 for A216 WCB)

Pressure (Bar)	19.6	19.6	17.9	15.8	13.8	11.7	9.6	8.6	7.6	6.5	5.5
Temperature (°C)	-29	38	93	149	204	260	316	343	371	399	425

PRESSURE / TEMPERATURE GRAPH :

Pressure

(Bar)

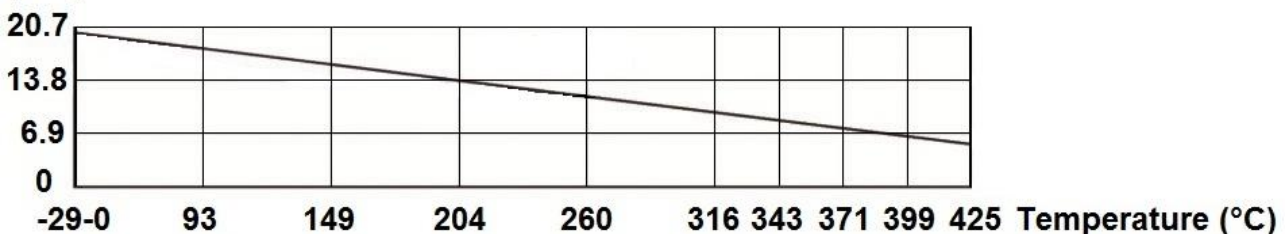

RANGE :

- Carbon steel swing check valve flanged R.F. Class 150 (PN20) Ref. 373 from DN 50 to DN 400 (NPS 2" to 16")

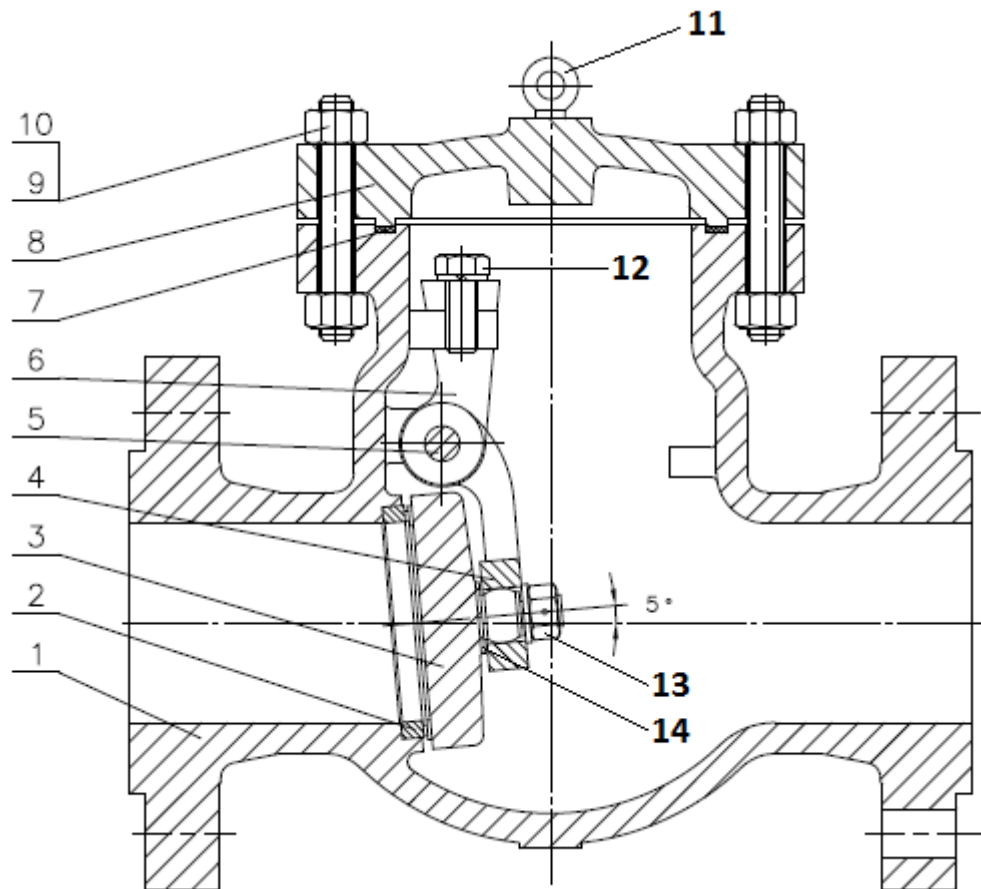
CARBON STEEL SWING CHECK VALVE FLANGED CLASS 150 PN20 TRIM8
MATERIALS :

Item	Designation	Materials
1	Body	ASTM A216 WCB
2	Seat	ASTM A105 + stellite Gr.6
3	Disc	ATM A216 WCB + 13Cr
4	Stem	ASTM A216 WCB
5	Pin	ASTM A276-420
6	Support	ASTM A216 WCB
7	Bonnet gasket	Graphite + AISI 304
8	Bonnet	ASTM A216 WCB
9	Stud bolt	ASTM A193 Gr B7
10	Nut	ASTM A194 Gr 2H
11	Hoisting eye	Steel 1025
12	Screw	ASTM A193 Gr B7
13	Nut	ASTM A194 Gr 2H
14	Washer	ASTM A276-420

CARBON STEEL SWING CHECK VALVE FLANGED CLASS 150 PN20 TRIM8

SIZE (in mm) :

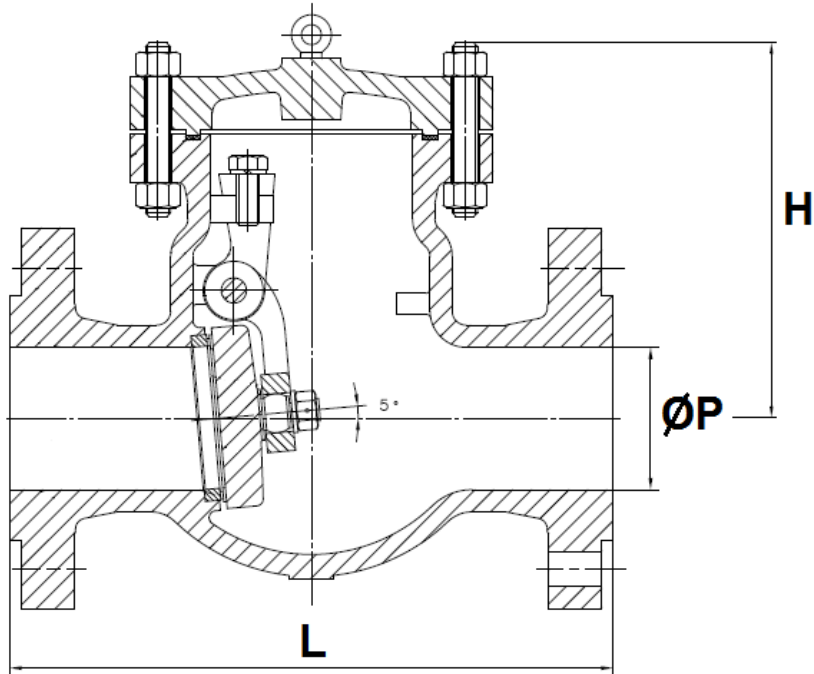

OPENING ANGLE :

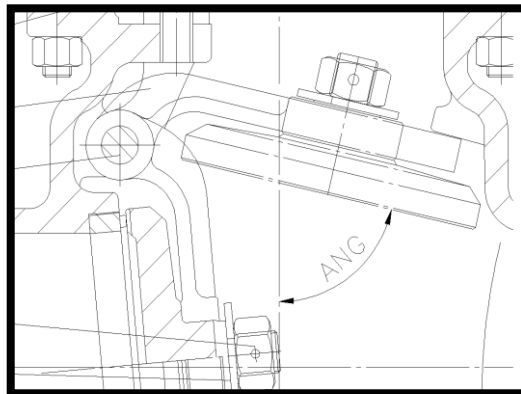

DN (mm)	50	80	100	125	150	200	250	300	350	400
NPS (")	2"	3"	4"	5"	6"	8"	10"	12"	14"	16"
Ø P	51	76	102	127	152	203	254	305	337	388
L	203	241	292	330	356	495	622	699	787	864
H	152	175	204	231	293	353	390	432	460	490
Opening angle	55°			60°			63°			65°
Weight (Kg)	17	26	42	59	69	114	185	253	410	468
Ref.	373050	373080	373100	373125	373150	373200	373250	373300	373350	373400

CARBON STEEL SWING CHECK VALVE FLANGED CLASS 150 PN20 TRIM8

FLANGES SIZE CLASS 150 PN20 (in mm) :

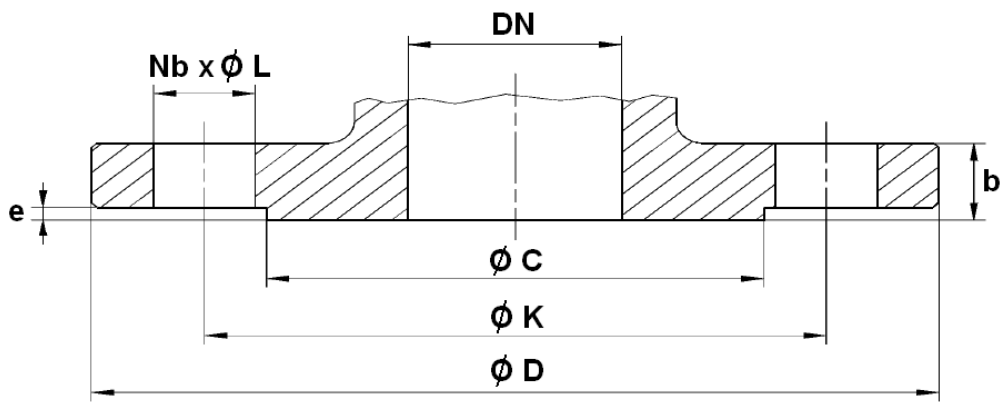

DN (mm)	50	80	100	125	150	200	250	300	350	400
NPS (")	2"	3"	4"	5"	6"	8"	10"	12"	14"	16"
Ø C	92.1	127	157.2	185.7	215.9	269.9	323.8	381	412.8	469.9
Ø D	150	190	230	255	280	345	405	485	535	595
Ø K	120.7	152.4	190.5	215.9	241.3	298.5	362	431.8	476.3	539.8
Nb x Ø L	4 x 19	4 x 19	8 x 19	8 x 22	8 x 22	8 x 22	12 x 26	12 x 26	12 x 29	16 x 29
b	16.3	19.5	24.3	24.3	25.9	29	30.6	32.2	35.4	37
e	2	2	2	2	2	2	2	2	2	2

CARBON STEEL SWING CHECK VALVE FLANGED CLASS 150 PN20 TRIM8
STANDARDS :

- Manufacturer certified ISO 9001 :2015 and ISO 14001 : 2015
- DIRECTIVE 2014/68/EU : CE N° 0036
Risk category III module H
- Certificate 3.1 on request
- Designing according to API 594
- Pressure tests according to API 598, table 6
- Length according to ASME B16.10, table 1 A15 series and EN 558 series 10 (EN558 series 21 for DN400 16")
- Flanges R.F. according to ASME B16.05 Class 150
- ATEX Group II Category 2 G/2D Zone 1 & 21 Zone 2 & 22 (optional marking) according to directive 2014/34/EU
- Materials according to NACE MR 01-75 **on request**

ADVICE : Our opinion and our advice are not guaranteed and Lauridsen Group shall not be liable for the consequences of damages. The customer must check the right choice of the products with the real service conditions.

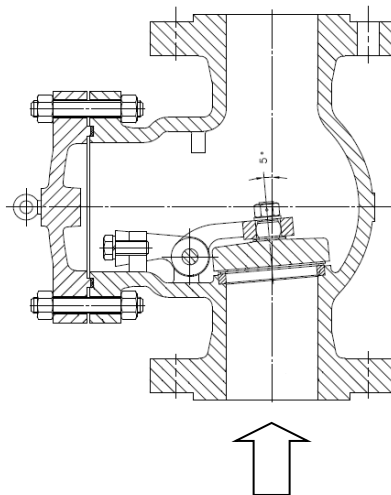
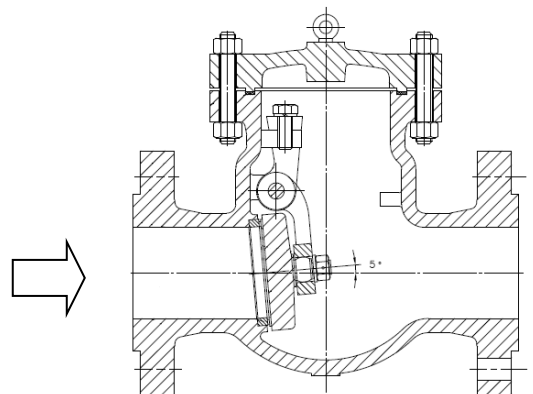
INSTALLATION POSITIONS :
Vertical position (ascendant fluid)

Horizontal position

CARBON STEEL SWING CHECK VALVE FLANGED CLASS 150 PN20 TRIM8**INSTALLATION INSTRUCTIONS****GENERAL GUIDELINES :**

- Ensure that the check valves to be used are appropriate for the conditions of the installation (type of fluid, pressure and temperature).
- Be sure to have enough valves to be able to isolate the sections of piping as well as the appropriate equipment for maintenance and repair.
- Ensure that the valves to be installed are of correct strength to be able to support the capacity of their usage.

INSTALLATION INSTRUCTIONS :

- **Remove the disc hold before using.**
- **Before installing the check valves, clean and remove any objects from the pipes** (in particular bits of sealing and metal) which could obstruct and block the valves.
- **Ensure that both connecting pipes either side of the check valve (upstream and downstream) are aligned (if they're not, the valves may not work correctly).**
- **Make sure that the two sections of the pipe (upstream and downstream) match, the check valve unit will not absorb any gaps. Any distortions in the pipes may affect the tightness of the connection, the working of the check valve and can even cause a rupture. To be sure, place the kit in position to ensure the assembling will work.**
- **If sections of piping do not have their final support in place, they should be temporarily fixed. This is to avoid unnecessary strain on the check valve.**
- If there is a direction changing or if there's another material, it's better to take away the check valve so that it is outside the turbulence area (**between 3 and 5 times the ND before and after**).
- After a pump please refer to **FD CEN/TR 13932** to install the check valve :
 - If it is essential to keep priming the pump, a non-return check valve can be fitted to the suction pipe at a distance **L1 (straight length suction) > 10xD1 (diameter suction)**
The check valve is designed to meet the maximum flow rate in service
 - In other cases, the non-return check valve is mounted on the discharge pipe at a distance of **L2 (straight length at discharge) > 3xD2 (diameter at discharge)**
- Respect the flow direction indicated by the arrow
- **For an installation in ATEX area, check the conductivity between the valve, the upstream pipe and the downstream pipe and make sure the pipe is connected to the earth.**

