

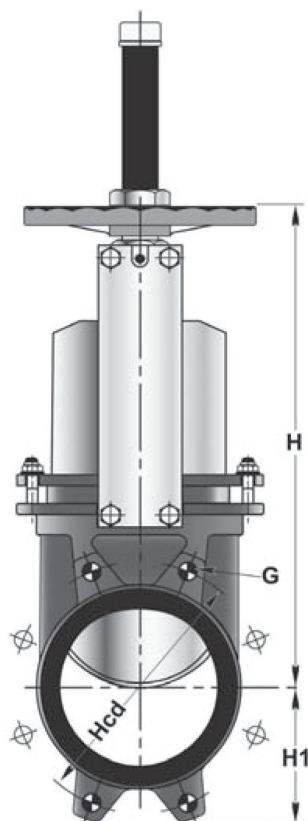

Knife Gate Valve PN 10 Wafer Straight SS316

Model/Ref: 396891



*Partnership.
Without Limits.*

www.lauridsenindustri.dk

Knife Gate Valve PN 10 Wafer Straight SS316

No	Part	Material
1	Body	CF8M
2	Seat	RCH1000
3	Slide	SS316
4	Gland	CF8M
5	Packning	Sint.+PTFE
6	Packning	EPDM
7	Bolt	316
8	Support	Cast steel
9	Closur cap	SS316
10	Board	EPDM
11	Closur cap	CF8M
12	Deflector	CA15/CF8M
13	Board	Belpa DW
14	Steam	Stainless steel SS303
15	Drive nut	Bronze
16	Froction washer	SS304
17	Bridge	Cast steel
18	Handwheel	Cast iron
19	Hood	Cast steel

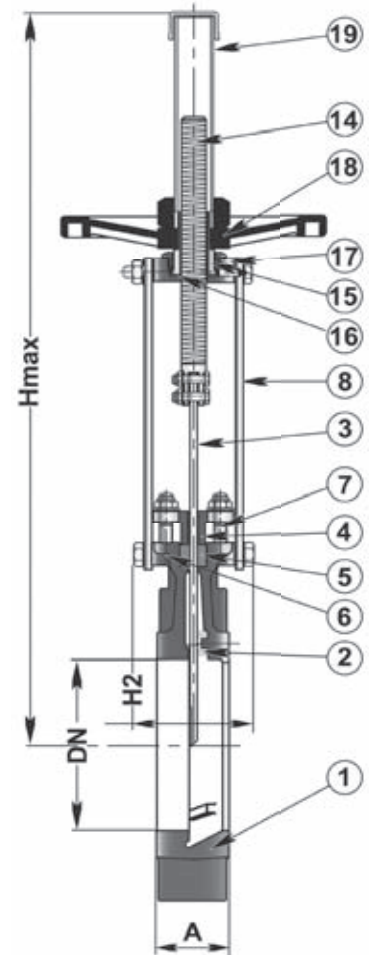
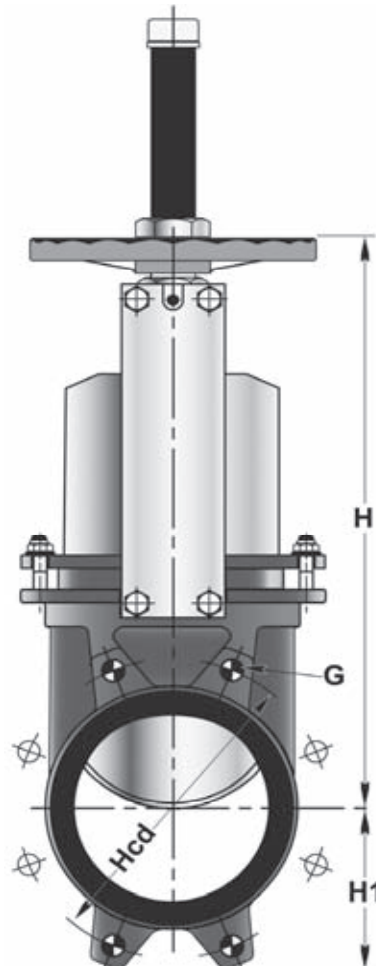
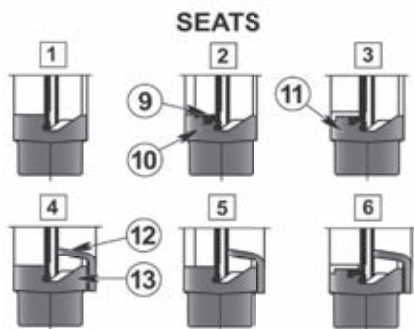

Variants:
 Various actuators
 Other dimensions/materials on request

DN	H1	H2	Hcd	H	G	L	Hmax	Max working-pressure	Weight Kg
								Mpa 100 °C	
50	63	92	125	295	M16x4	40	417	1,0	7,0
65	70	92	145	320	M16x4	40	442	1,0	8,0
80	92	92	160	346	M16x4	50	469	1,0	9,0
100	105	92	180	386	M16x4	50	509	1,0	11,0
125	120	102	210	420	M16x4	50	593	1,0	13,0
150	130	102	240	471	M20x4	60	644	1,0	17,0
200	160	119	295	582	M20x4	60	825	0,8	28,0
250	198	119	350	683	M20x6	70	1026	0,6	40,0
300	234	119	400	790	M20x6	70	1126	0,6	56,0
350	256	194	460	907	M20x10	96	1357	0,6	94,0
400	298	194	515	1014	M24x10	100	1463	0,5	116,0
450	305	290	565	1106	M24x14	106	1651	0,3	162,0
500	340	290	620	1211	M24x14	110	1756	0,3	191,0
600	400	290	725	1417	M27x14	110	2062	0,4	264,0