



3 WAYS BALL VALVE FLANGED ISO PN16 (783-784-785-786)

Model/Ref: 783 - 786



*Partnership.
Without Limits.*

www.lauridsenindustri.dk

3 WAYS BALL VALVE FLANGED ISO PN16 (783-784-785-786)



Size : DN 25 to 150
Connection end : Flanges ISO PN16 R.F.
Min Temperature : -30°C in stainless steel and -20°C in carbon steel
Max Temperature : + 150°C
Max Pressure : 16 Bars
Specifications : ISO mounting pad
PTFE filled with glass seat
Anti blow-out stem
Atex

Materials : Carbon steel or Stainless steel

3 WAYS BALL VALVE FLANGED ISO PN16 (783-784-785-786)
SPECIFICATIONS :

- Full bore
- Anti blow-out stem
- PTFE seat filled with glass
- Locking device
- ISO 5211 mounting pad
- Tightness on 3 ways
- L or T port
- Trunnion mounted ball valve from DN100 to DN150

USE :

- Chemical industries, petrochemical industries, hydraulic installation, heating, water distribution, compressed air
- Min and max Temperatures Ts : -30°C to + 150°C for stainless steel type **Ref. 785 and 786**
- Min and max Temperatures Ts : -20°C to + 150°C for carbon steel type **Ref. 783 and 784**
- Max Pressure PN : 16 bars (see graph)

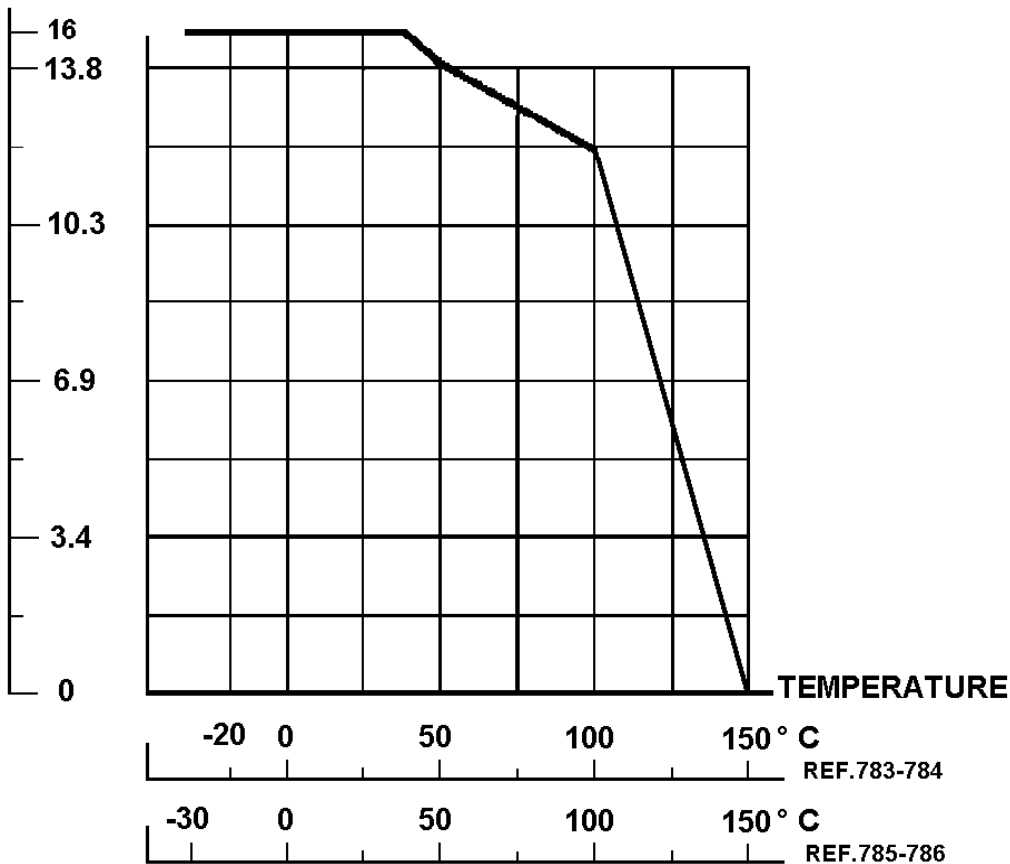
PRESSURE / TEMPERATURE GRAPH (STEAM EXCLUDED) :
**PRESSURE
BAR**

3 WAYS BALL VALVE FLANGED ISO PN16 (783-784-785-786)

RANGE :

- Carbon steel L port **Ref. 783** DN 25 to DN 150
- Carbon steel T port **Ref. 784** DN 25 to DN 150
- Stainless steel L port **Ref. 785** DN 25 to DN 150
- Stainless steel T port **Ref. 786** DN 25 to DN 150

ENDS :

- Flanges R.F. ISO PN16

3 WAYS BALL VALVE FLANGED ISO PN16 (783-784-785-786)

MATERIALS DN 25 - 40 :

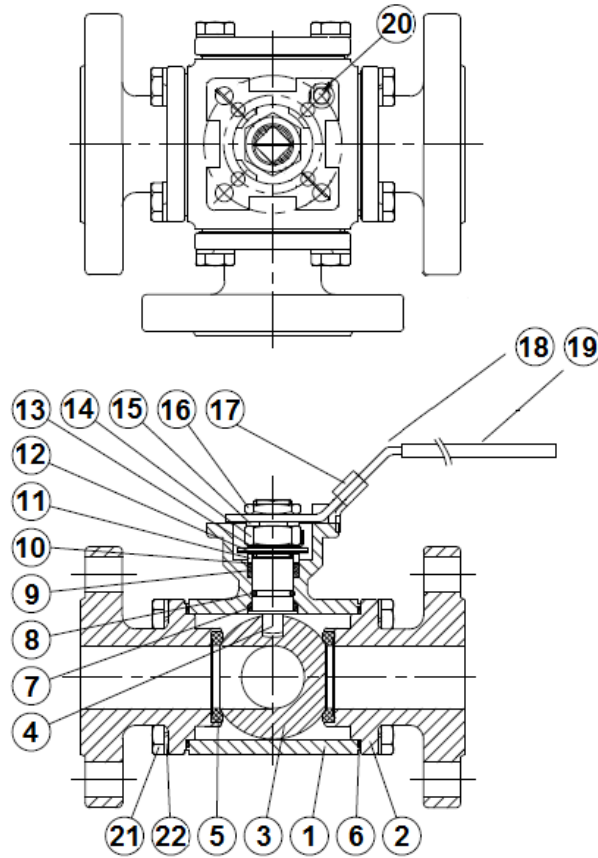

(* : Included in gaskets kit)

Item	Designation	Materials 783/784	Materials 785/786
1	Body	ASTM A216 WCB	ASTM A351 CF8M
2	Ends	ASTM A216 WCB	ASTM A351 CF8M
3	Ball	ASTM A351 CF8	ASTM A351 CF8M
4	Stem	SS 304	SS 316
5*	Seat	PTFE filled with 15% glass	
6*	Body gasket	PTFE	
7*	Thrust washer	PTFE	
8*	O ring	FKM	
9*	Packing	PTFE	
10*	Packing follower	PTFE filled with 25% grafoil	
11	Gland	SS 304	
12	Elastic washer	SS 410	
13	Stop washer	SS 304	
14	Packing nut	SS 304	
15	Handle washer	SS 304	
16	Handle nut	SS 304	
17	Locking device	SS 304	
18	Handle	SS 304	
19	Handle cover	Plastic	
20	Stopper	SS 304	
21	Screw	SS 304	
22	Washer	SS 304	

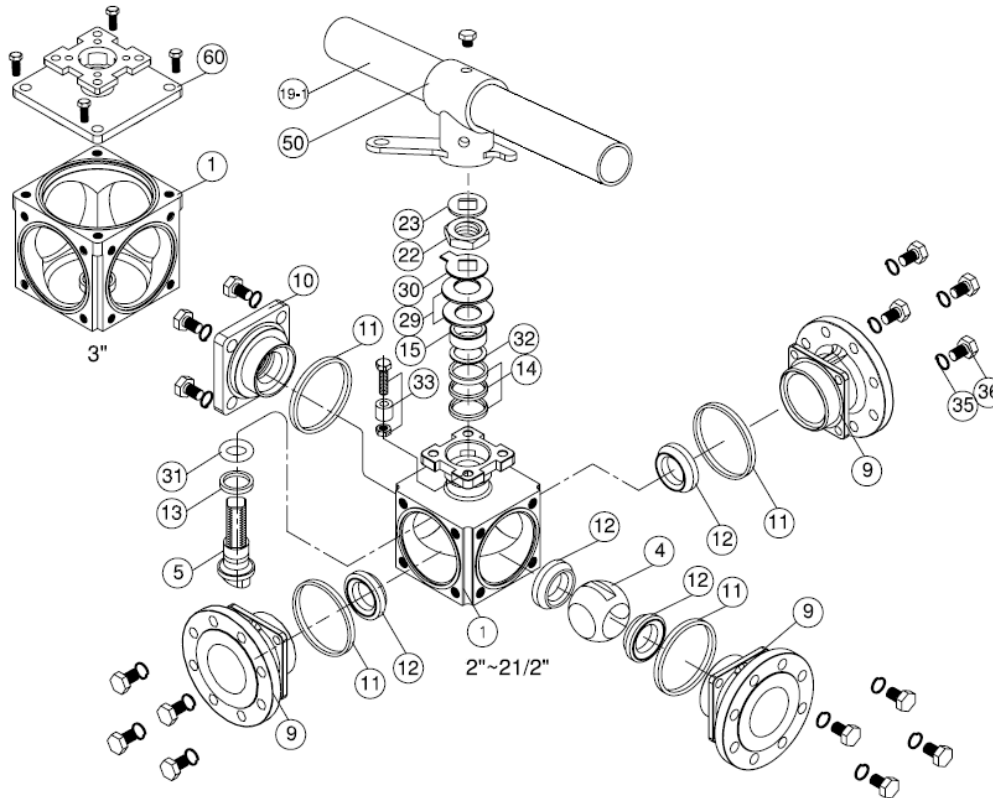
3 WAYS BALL VALVE FLANGED ISO PN16 (783-784-785-786)
MATERIALS DN 50 - 80 :

Item	Designation	Materials 783/784	Materials 785/786
1	Body	ASTM A216 WCB	ASTM A351 CF8M
4	Ball	ASTM A351 CF8	ASTM A351 CF8M
5	Stem	SS 304	SS 316
9	Ends	ASTM A216 WCB	ASTM A351 CF8M
10	Bliand cap	ASTM A216 WCB	ASTM A351 CF8M
11*	Body seal	PTFE	
12*	Seat	PTFE filled with 15% glass	
13*	Thrust washer	PTFE	
14*	Stem packing	PTFE	
15	Gland	SS 304	
19-1	Handle	Iron	
22	Stem nut	SS 304	
23	Handle washer	SS 304	
29	Elastic washer	SS 410	
30	Stop washer	SS 304	
31*	O ring	FKM	
32*	Packing follower	PTFE filled with 15% grafoil	
33	Stop pin	SS 304	
35	Bolt washer	SS 304	
36	Bolt	SS 304	
50	Handle adapter	ASTM A351 CF8	

(* : Included in gaskets kit)

3 WAYS BALL VALVE FLANGED ISO PN16 (783-784-785-786)

MATERIALS DN 100-150 :

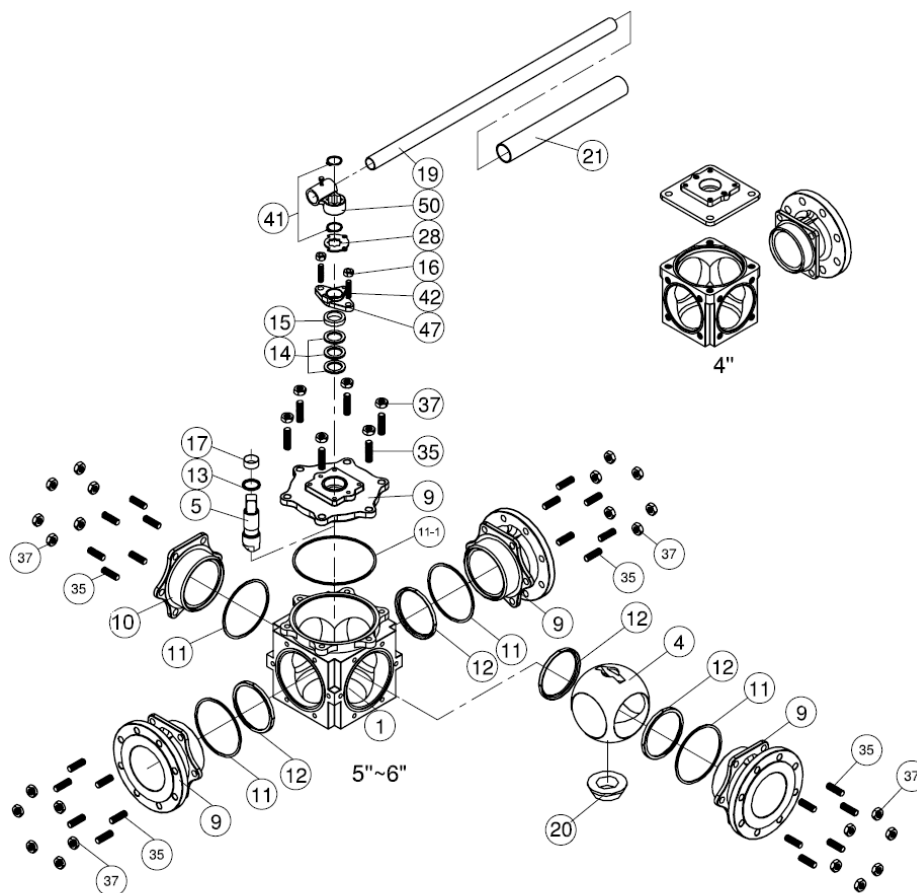



Item	Designation	Materials 783/784	Materials 785/786
1	Body	ASTM A216 WCB	ASTM A351 CF8M
4	Ball	ASTM A351 CF8	ASTM A351 CF8M
5	Stem	SS 304	SS 316
9	Ends	ASTM A216 WCB	ASTM A351 CF8M
10	Bliand cap	ASTM A216 WCB	ASTM A351 CF8M
11*	Body seal	PTFE	
11-1*	Top seal	PTFE	
12*	Seat	PTFE filled with 15% glass	
13*	Thrust washer	PTFE	
14*	Stem packing	PTFE	
15	Gland bush	SS 304	
16	Gland nut	SS 304	
17*	Stem bushing	PTFE	
19	Handle	Iron	
20	Set bolt	SS 304	
21	Handle cover	Plastic	
28	Stop plate	SS 304	
35	Bolt	SS 304	
37	Bolt nut	SS 304	
41	Snap ring	SS 304	
42	Gland bolt	SS 304	
47	Gland flange	ASTM A351 CF8	
50	Handle adapter	ASTM A351 CF8	

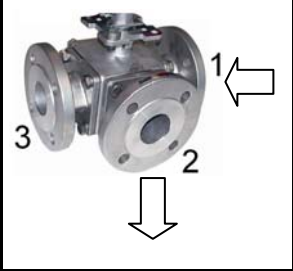
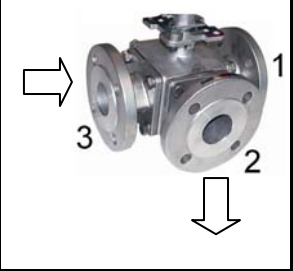
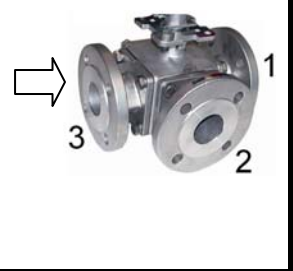
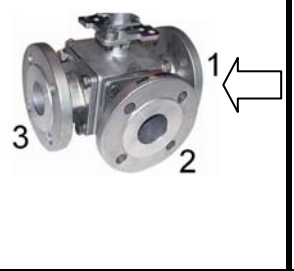
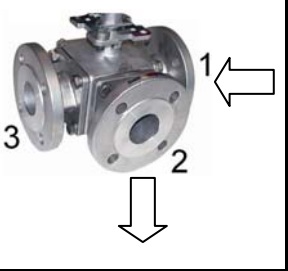
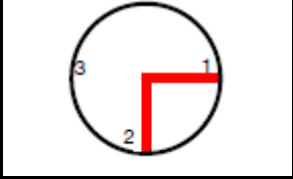
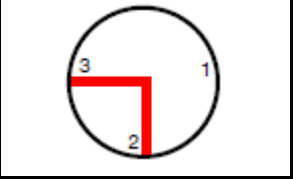

(* : Included in gaskets kit)

3 WAYS BALL VALVE FLANGED ISO PN16 (783-784-785-786)
POSSIBLE POSITIONS :

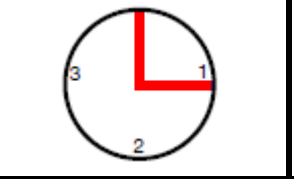
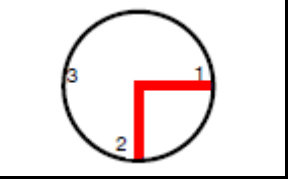
L PORT (only 2 consecutive positions are possibles)

Position L1	Position L2	Position L3	Position L4	Position L5
				
				

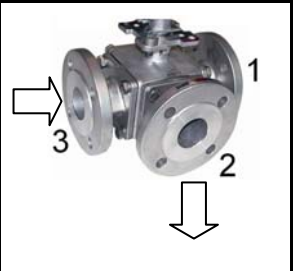
T PORT (only 2 consecutive positions are possibles)

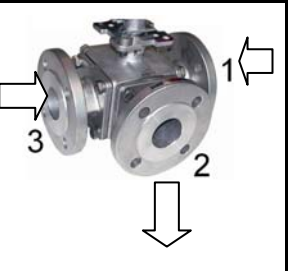
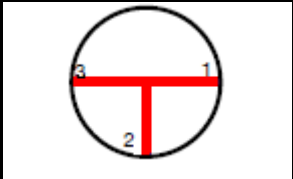
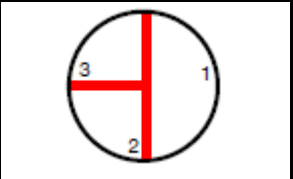
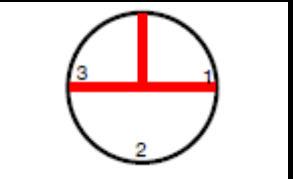
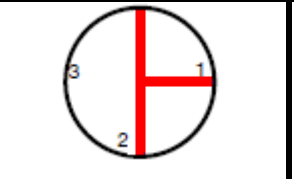
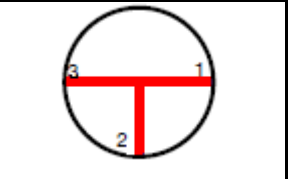
Position T1	Position T2	Position T3	Position T4	Position T5
				
				

3 WAYS BALL VALVE FLANGED ISO PN16 (783-784-785-786)

SIZE DN 25 - 40 (in mm) :

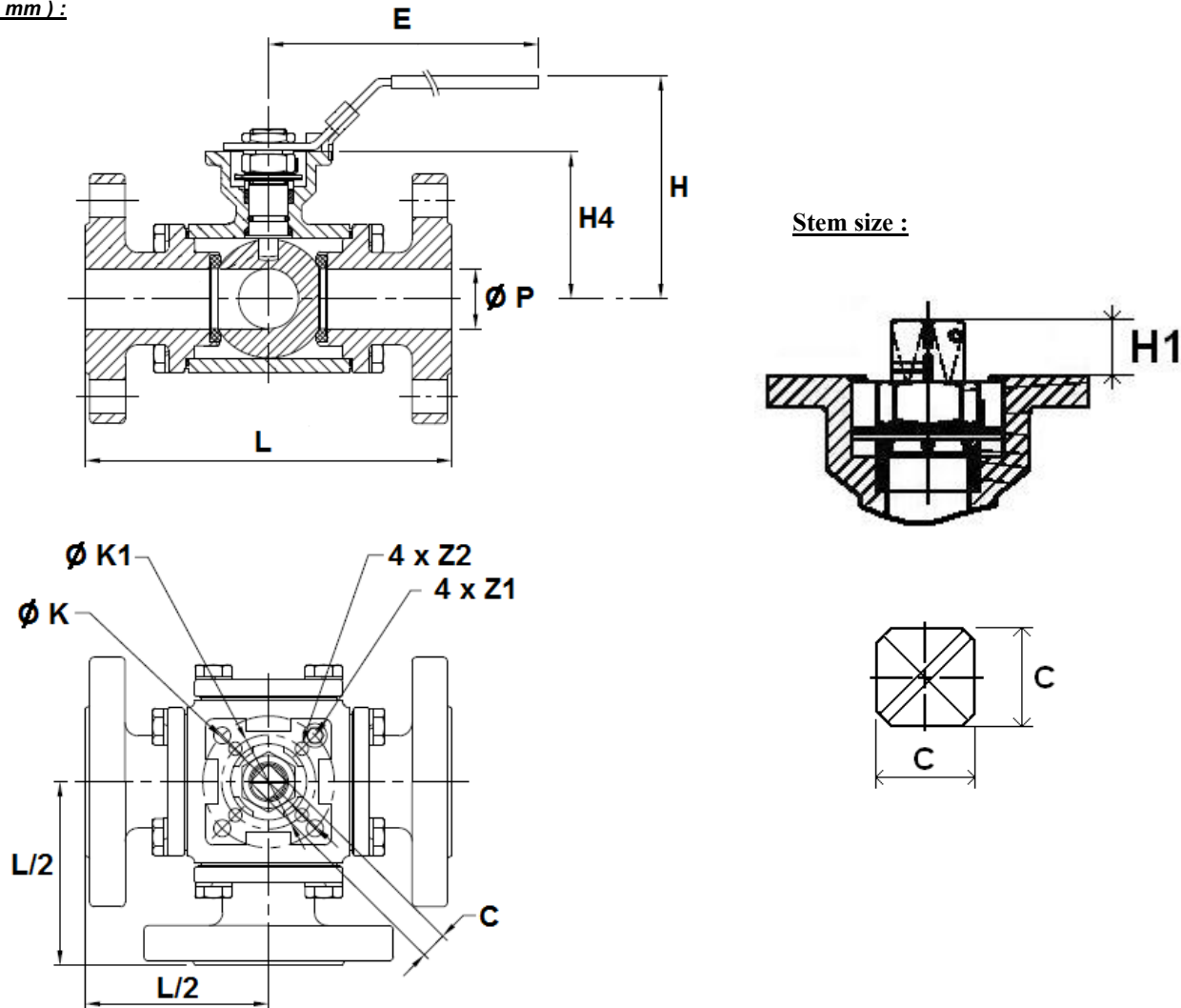

Ref.	DN	25	32	40
783 / 784	Ø P	25	32	38
	L	185	195	232
	L/2	92.5	97.5	116
	E	218	235	235
	H	102	118.5	127
	H1	11.5	15.2	14.3
785 / 786	H4	64	79	88.5
	C	9	14	14
	Ø K	50	70	70
	ISO	F05	F07	F07
	Ø K1	-	50	50
	ISO 1	-	F05	F05
	4xZ1	4 x 7	4 x 9	4 x 9
	4xZ2	-	4 x 7	4 x 7
Weight (Kg)		7.5	10.9	14.9

3 WAYS BALL VALVE FLANGED ISO PN16 (783-784-785-786)

SIZE DN 50-80 (in mm) :

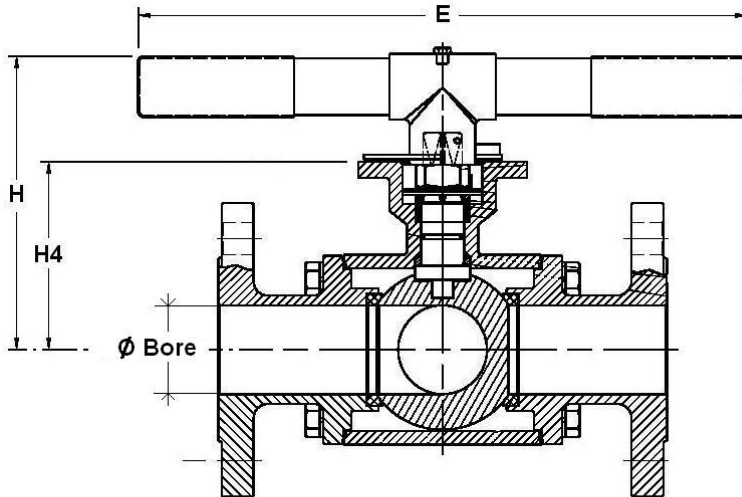

Stem size :

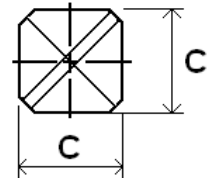
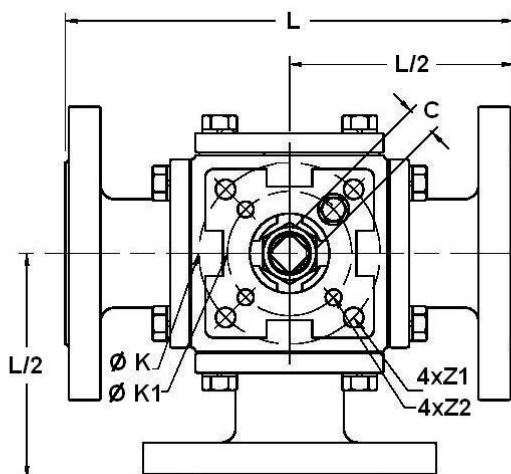
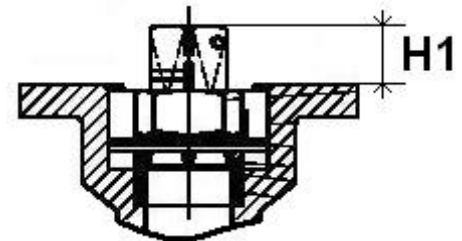

Ref.	DN	50	65	80
783 / 784	Ø Bore	49	64	76
	L	253	278	292.2
	L/2	126.5	139	146.1
	E	300	300	300
	H	156.6	168.85	178
	H1	17.8	17.5	17.5
785 / 786	H4	105.8	117.3	128
	C	17	17	17
	Ø K	102	102	102
	ISO	F10	F10	F10
	Ø K1	70	70	70
	ISO 1	F07	F07	F07
	4xZ1	4x11	4x11	4x11
	4xZ2	4x9	4x9	4x9
Weight (Kg)	19	23.75	34.5	

3 WAYS BALL VALVE FLANGED ISO PN16 (783-784-785-786)

SIZE DN 100-150 (in mm) :

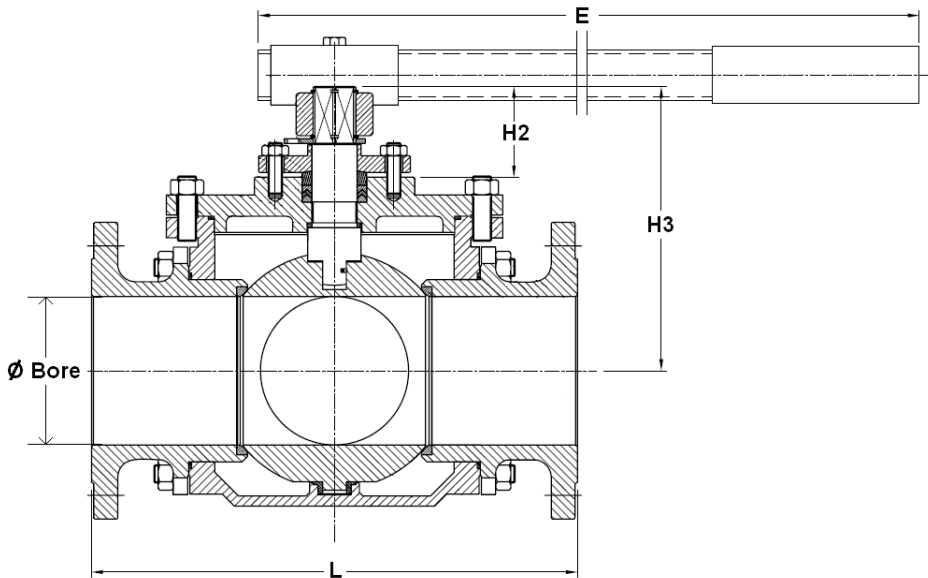

Stem size :

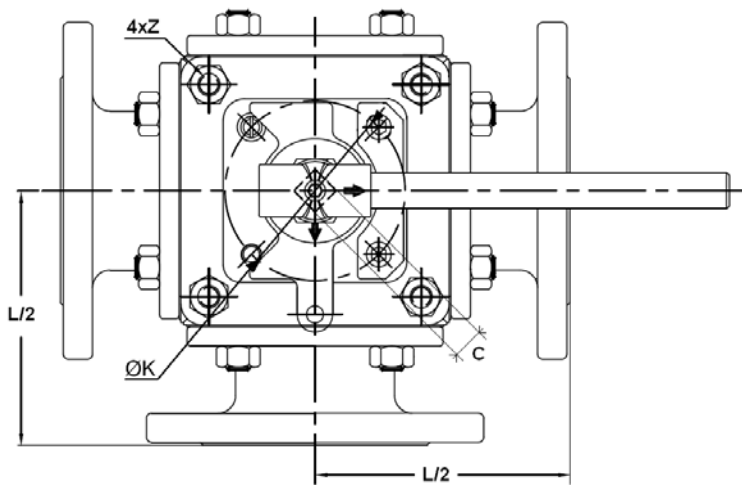
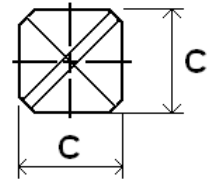
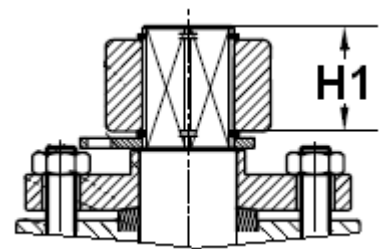

Ref.	DN	100	125	150
783 / 784	Ø Bore	99	125	150
	L	360	416	473
	L/2	180	208	236.5
	E	600	600	800
	H1	33	33	43.5
	H2	70	70	77.5
785 / 786	H3	193	233	266
	C	27	27	36
	Ø K	125	125	140
	ISO	F12	F12	F14
	4xZ	4x12	4x12	4x16
783/785	Weight (Kg)	67.4	95	124
784/786	Weight (Kg)	61.8	95	127

3 WAYS BALL VALVE FLANGED ISO PN16 (783-784-785-786)

FLANGES SIZE (in mm) :

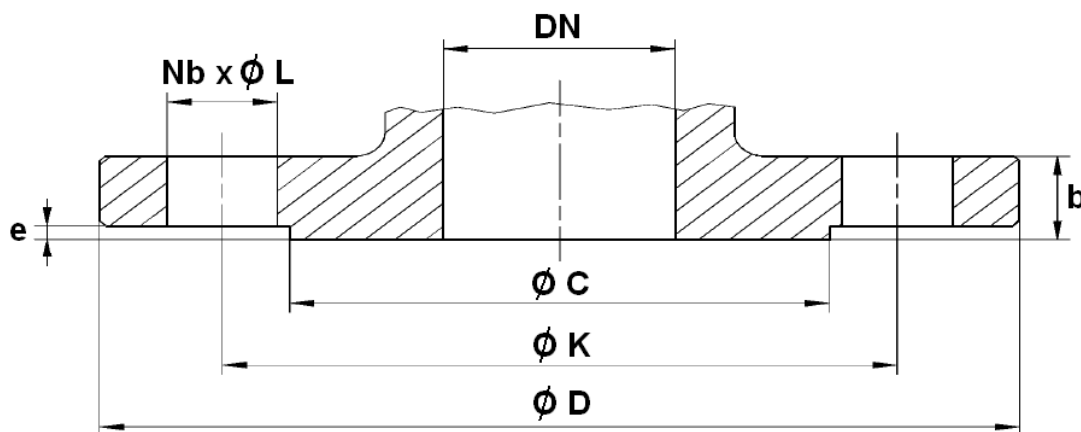

DN	25	32	40	50	65	80	100	125	150
Ø C	68	78	88	102	122	138	158	188	212
Ø D	115	140	150	165	185	200	220	250	285
Ø K	85	100	110	125	145	160	180	210	240
Nb x Ø L	4 x 14	4 x 18	4 x 18	4 x 18	4 x 18	8 x 18	8 x 18	8 x 18	8 x 22
b	18	18	18	20	18	20	20	22	22
e	2	2	2	2	2	2	2	2	2

3 WAYS BALL VALVE FLANGED ISO PN16 (783-784-785-786)

TORQUE VALUES (in Nm without safety coefficient) :

DN	25	32	40	50	65	80	100	125	150
Torque (Nm)	16.2	26	44	126	174	210	290	572	924

FLOW COEFFICIENT Kvs (M3 / H) :

REF.	DN	25	32	40	50	65	80	100	125	150
783 / 785	Kvs (M3 / H)	30	50	72	131.2	227.7	311.4	554.7	893.3	1328.6
784 / 786 (Straight)	Kvs (M3 / H)	37	61	88	160.6	278.9	381.3	679.3	1094.1	1627.2
784 / 786 (Branch)	Kvs (M3 / H)	21	35	51	92.8	161	220.2	392.2	631.7	939.5

STANDARDS :

- Fabrication according to ISO 9001 : 2008
- DIRECTIVE 97/23/CE : CE N° 0038
Risk Category II
- Tests according to EN 12266-1, Range A
- Flanges R.F. ISO PN16 according to EN 1092-1
- ISO 5211 mounting pad
- ATEX Group II Category 2 G/2D Zone 1 & 21 Zone 2 & 22 (optional marking)

ADVICE :Our opinion and our advice are not guaranteed and Lauridsen Industri shall not be liable for the consequences of damages.

The customer must check the right choice of the products with the real service conditions.

3 WAYS BALL VALVE FLANGED ISO PN16 (783-784-785-786)**INSTALLATION INSTRUCTIONS****GENERAL GUIDELINES :**

- Ensure that the valves to be used are appropriate for the conditions of the installation (type of fluid, pressure and temperature).
- Be sure to have enough valves to be able to isolate the sections of piping as well as the appropriate equipment for maintenance and repair.
- Ensure that the valves to be installed are of correct strength to be able to support the capacity of their usage.
- **Installation of all circuits should ensure that their function can be automatically tested on a regular basis (at least two times a year).**

INSTALLATION INSTRUCTIONS :

- **Before installing the valves, clean and remove any objects from the pipes** (in particular bits of sealing and metal) which could obstruct and block the valves.
- **Ensure that both connecting pipes either side of the valve (upstream and downstream) are aligned (if they're not, the valves may not work correctly).**
- **Make sure that the two sections of the pipe (upstream and downstream) match, the valve unit will not absorb any gaps. Any distortions in the pipes may affect the tightness of the connection, the working of the valve and can even cause a rupture.** To be sure, place the kit in position to ensure the assembling will work.
- **If sections of piping do not have their final support in place, they should be temporarily fixed. This is to avoid unnecessary strain on the valve.**
- Tighten the bolts in cross.
- It's recommended to operate the valve (open and close) 1 to 2 times per year