



BRASS ROTOR SIGHT GLASS C156

Model/Ref: 221004



*Partnership.
Without Limits.*

BRASS ROTOR SIGHT GLASS C156
MAIN CHARACTERISTICS

The sight glass C156 is dedicated to the visual control and inspection of fluids or gas flow, thanks to his rotor. It is particularly adapted to low pressure and standard temperature applications. C156 is a one way sight glass. The direction of the flow must follow the arrow stamped on the body.

AVAILABLE MODELS

Size 1/2"

BSP screwed connections.

CLASSIFICATION ACCORDING TO PED 97/23

A3 §3

LIMITS OF USE

PS : 6 bar

TS : from +10°C to +80°C

Utilisation on fluids compatible with polycarbonate

CONSTRUCTION

Item	Description	Material
1	Body	Brass CB 754S
2	Gasket	NBR
3	Cover	Polycarbonate
4	Screw	Brass CW 617N
5	Rotor	Nylon 6.6
6	Stem	Stainless steel AISI 304

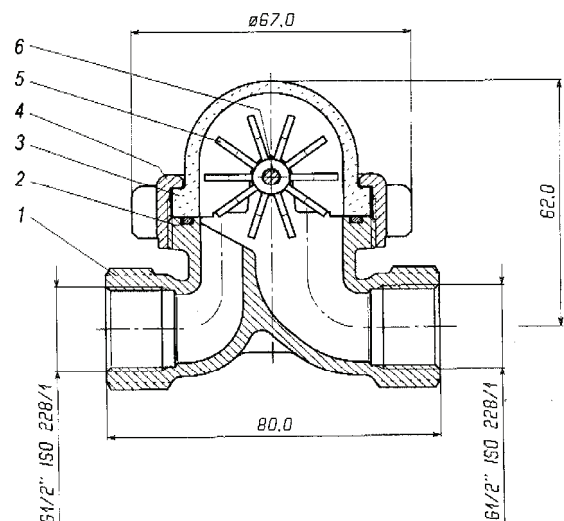

BRASS ROTOR SIGHT GLASS C156**INSTALLING AND MAINTAINING**

- Before installation or maintaining, shut off the line using upstream and downstream valves.
- Remove the pressure inside and drain the pipe.
- If the pipe is warm, wait the complete cooling to room temperature.
- Wear protections equipments adapted to this kind of operation (gloves and glasses).

Installing

- Decide the position of the sight glass on the line in order to make it visible for the operators.
- Install the sight glass by screwing the connections on the pipes ends.
- The arrow stamped on the body must follow the direction of the flow.

Maintaining

- Remove the cover and the glass.
- Clean the glass and the inner part of the body.
- Verify the state of the glass and check any starting of chemical corrosion or mechanical erosion. Replace it if necessary.

SPARE PARTS

Spare parts kits including 1 glass and 1 gasket.

Size	Ordering Code
1/2"	981010