



1133-1135 BUTTERFLY VALVES + UM ELECTRIC ACTUATOR

Model/Ref: 262504022060



*Partnership.
Without Limits.*

www.lauridsenindustri.dk

1133-1135 BUTTERFLY VALVES + UM ELECTRIC ACTUATOR
CHARACTERISTICS

The butterfly valves 1133 to 1135 are dedicated to the automatic opening/shut-off of common fluid pipes. It has a cast iron body. Thanks to various material possibilities for both the butterfly and the sleeve, it can be used in different applications. The lug type body enables the mounting between PN10/16 flanges and the long neck pattern makes the mounting on insulated pipes possible. The ISO 5211 pad enables the direct mounting of the UM electric actuator. It is perfectly adapted for an indoor or outdoor service (under shelter).

AVAILABLE ITEMS

DN 40 to DN 150

Flanged connections PN10/16

Voltage: 24 V AC, 24 V DC and 230 V AC

Ref.	Butterfly	Seat	Application examples	Min. TS	Max. TS
1133	Stainless steel	EPDM	Demineralised water – Alkaline materials	-10 °C	+110 °C
1135	Cast iron	EPDM	Cold water – hot water	-10 °C	+110 °C

LIMITS OF USE

Max. allowable pressure (PS)	16 bar until DN 300
Min./max. allowable temperature (TS)	According to the upper chart
Prohibited use	Steam, natural gas
Room temperature	-10 °C / +50 °C
Service	S4 - 30% - 10 starts/h



The following data is for information purpose only and may be subject to alteration without prior notice

1133-1135 BUTTERFLY VALVES + UM ELECTRIC ACTUATOR
DIRECTIVES AND DEVELOPMENT STANDARDS APPLICABLE

	Standard	Notified bodies		Standard
97/23/EC Pressure Equipment Directive	Cat. III module H	0035	Valve testing	API 598
Face-to-face dimension	ISO 5752 series 20		Actuator attachment	ISO 5211
Flange dimension	EN 1092-1			

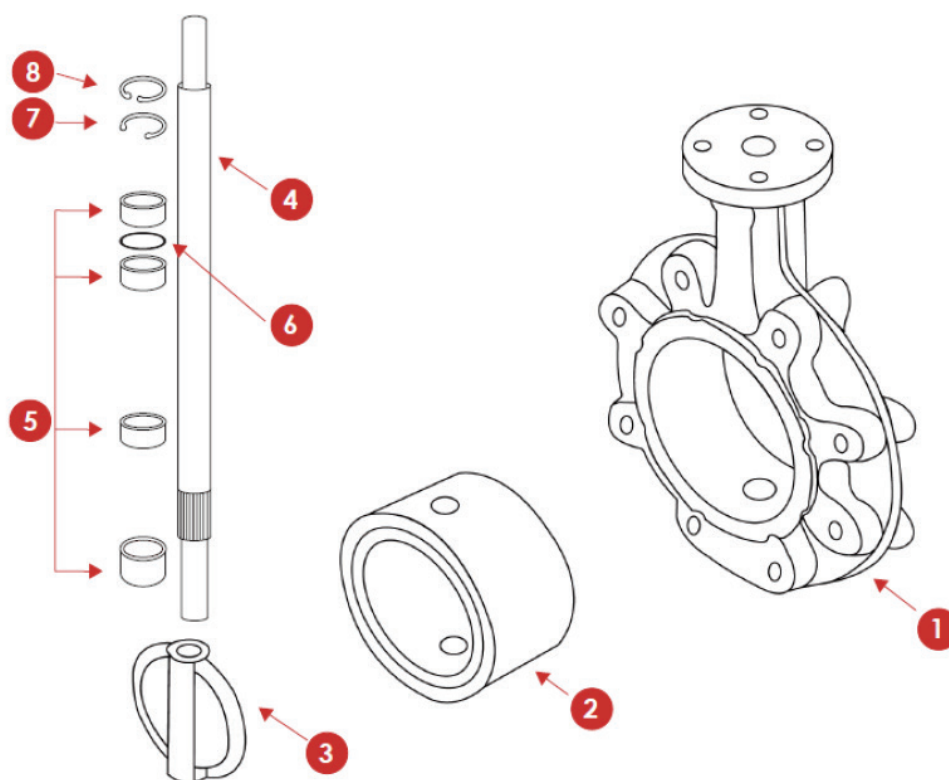

CONSTRUCTION

#	Item	1133	1135
1	Body	Cast iron EN GJL-250	
2	Seat	EPDM	EPDM
3	Butterfly	Stainless steel A351 CF8M /1.4408	Nickel plated cast iron EN GJS-400-15
4	Stem	Stainless steel 416	
5	Bearings	PTFE	
6	O-ring	NBR	NBR
7	Securing rings/ Circlips	Steel	
8	Securing rings/ Circlips	Steel	

The following data is for information purpose only and may be subject to alteration without prior notice

1133-1135 BUTTERFLY VALVES + UM ELECTRIC ACTUATOR
DIMENSIONS (mm)

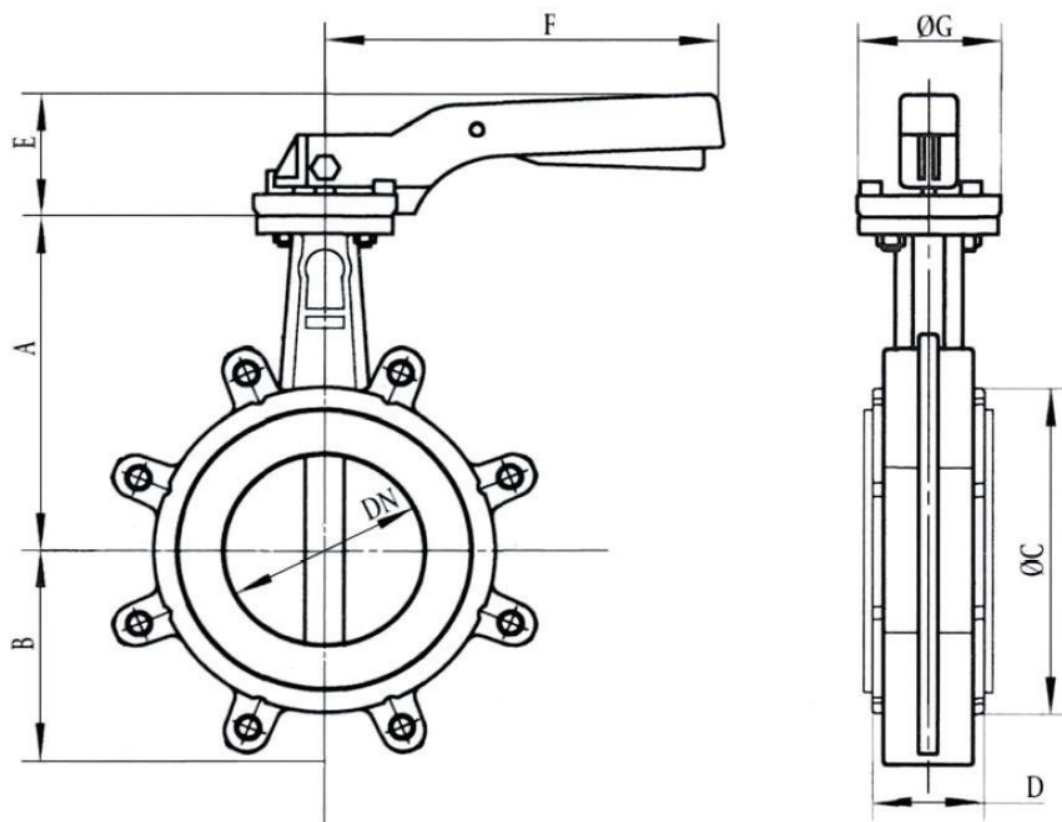
DN	40	50	65	80	100	125	150	200	250	300
A	130	136.5	142	158	180	192	215	242	280	310
B	61	77	87.5	95	107	121	144	171	205	235
Ø C	82	95	109	127	152	180	207	260	315	370
D	33	43	46	46	52	56	56	60	68	78
E	74	74	74	74	74	79	79	37	37	37
F	200	200	200	200	200	278	278	355	507	507
Ø G	65	65	65	65	65	90	90	125	150	150
Weight (kg)	2.43	3.13	3.73	4.98	5.64	9.06	10.9	167	32.3	45

FLOW FACTOR Kv (m³/h)

DN	40	50	65	80	100	125	150	200	250	300
Kv	78	98	167	258	512	872	1347	2675	4555	7037

The following data is for information purpose only and may be subject to alteration without prior notice

1133-1135 BUTTERFLY VALVES + UM ELECTRIC ACTUATOR

ACTUATION WITH UM

Suggested standard UM actuation under the following conditions:

- Electric actuator with an IP 65 plastic enclosure and steel gears
- A minimum 1.3 safety factor compared with the valve nominal torque rating,
- A maximum pressure differential up/downstream of 10 bar (=ΔP)

The actuator is directly mounted.

DN	Actuator	Power	Operating time 230 V AC	Operating time 24 V AC/DC	Standard equipment of the actuator
40	UMA3.5	10 W	10 s	15 s	2 adjustable limit switches 2 dry auxiliary switches Actuator thermal cut-out Manual override by key Visual position indicator Electrical connection: 1 gland pack ½" PF
50	UMA3.5	10 W	10 s	15 s	
65	UMA3.5	10 W	10 s	15 s	
80	UMA3.5	10 W	10 s	15 s	
100	UMC10	25 W	8 s	N/A	
125	UMC10	25 W	8 s	N/A	Optional equipment Anti-condensation heater
150	Refer to actuator 1135 + UV				
200					
250					

*Unloaded operating time given for information purpose only. May vary depending on the medium

For any other working conditions, please contact us.

ACTUATION OPTIONS

There are many different options, please contact our commercial department.

1	Electric actuator sized for a maximum pressure differential up/downstream over 10 bar (=ΔP)
2	UM electric actuator with a declutchable manual override by handwheel
3	Anti-condensation heater

The following data is for information purpose only and may be subject to alteration without prior notice