



**1113-1114 BUTTERFLY VALVES + NA ELECTRIC
ACTUATOR**

Model/Ref: 260950023110



*Partnership.
Without Limits.*

www.lauridsenindustri.dk

1113-1114 BUTTERFLY VALVES + NA ELECTRIC ACTUATOR

CHARACTERISTICS

The 1113-1114 double eccentric butterfly valves are high performance valves dedicated to the automatic shut-off of high pressure and/or low temperature fluids like steam, bitumen, thermal oils, alkali, etc. The valve has an assembly direction but its tightness is bi-directional. The one-piece butterfly stem is mounted on bearings and offers an antistatic device. Its firesafe construction enables its use in the hydrocarbon sector. The ISO 5211 pad allows the mounting of standardized actuators.

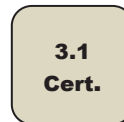

AVAILABLE ITEMS

1113: carbon steel body

1114: stainless steel body

DN 50 to DN 300, face-to-face dimensions according to the ISO 5752 series 20 standard

Flanged connections EN 1092 RF PN 25

Voltages: 24 V AC/DC, 230 V AC, 3~400 V AC

LIMITS OF USE

Max. allowable pressure (PS)	25 bar
Min./max. allowable temperature (TS)	Steel: -25 °C / +210 °C Stainless steel: -30 °C / +210 °C
Room temperature	-20 °C / +70 °C
Service	S2 – 70%

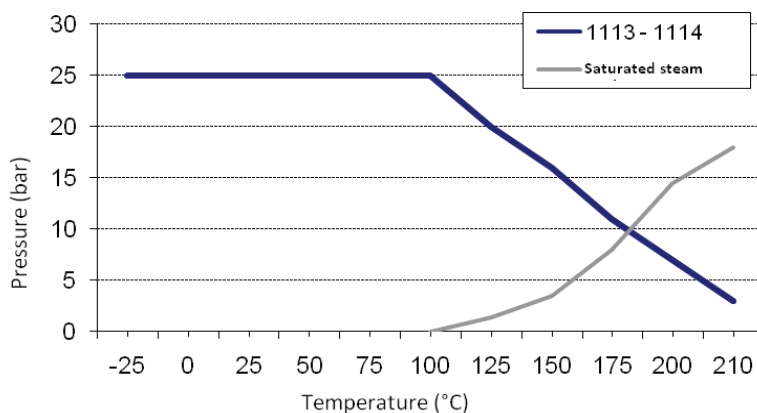

The following data is for information purpose only and may be subject to alteration without prior notice

1113-1114 BUTTERFLY VALVES + NA ELECTRIC ACTUATOR

DIRECTIVES AND DEVELOPMENT STANDARDS APPLICABLE

	Standard
97/23/EC Pressure Equipment Directive	Cat.III Module H - CE 0035
ATEX Directive	EN 13463-1 : II 2G/D
Construction	API 609 and MSS SP-68
Body materials	EN 1503-2
Material certificate	EN 10204
Flanges dimension	EN 1092-1
Face-to-face dimension	ISO 5752 series 20
Valve leakage	ANSI/FCI 70-2
Valve testing	ISO 5208 et MSS SP-61
Fire safe testing	API 607/5 – ISO 10497-5
Actuator attachments	ISO 5211

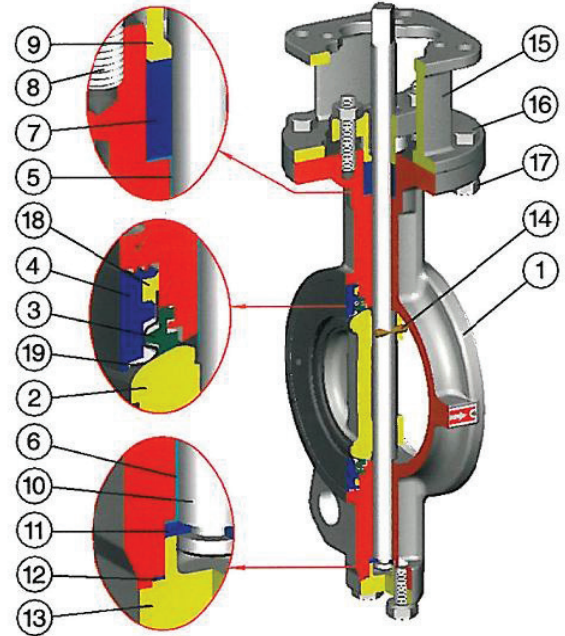

CONSTRUCTION

#	Item	Materials 1113	Materials 1114
1	Body	Carbon steel A216 WCB / 1.0619	Stainless steel A351 CF8M / 1.4408
2	Butterfly	Stainless steel A351 CF8M / 1.4408	
3	Seat	PTFE + 15 % Graphite	
4	Retainer	Stainless steel 1.4308	
5	Ring	PTFE + Stainless steel	
6	Ring	PTFE + Stainless steel	
7	Packing	Graphite	
8	Stud	ASTM A 193 B8	
9	Gland plate	Stainless steel 1.4308	
10	Stem	Stainless steel 364 630	
11	Thrust ring	Stainless steel ASTM A240 Gr. 316	
12	Gasket	Graphite	
13	Bottom cover	Carbon steel A216 WCB / 1.0619	Stainless steel A351 CF8M / 1.4408
14	Pin	ASTM A 182 F316	
15	Bracket	Carbon steel A216 WCB / 1.0619	Stainless steel A351 CF8M / 1.4408
16	Stud	ASTM A 193 B8	
17	Nut	ASTM A 194 B8	
18	Tightness	Graphite	
19	Metal seat	Stainless steel ASTM A240 Gr. 316	

The following data is for information purpose only and may be subject to alteration without prior notice

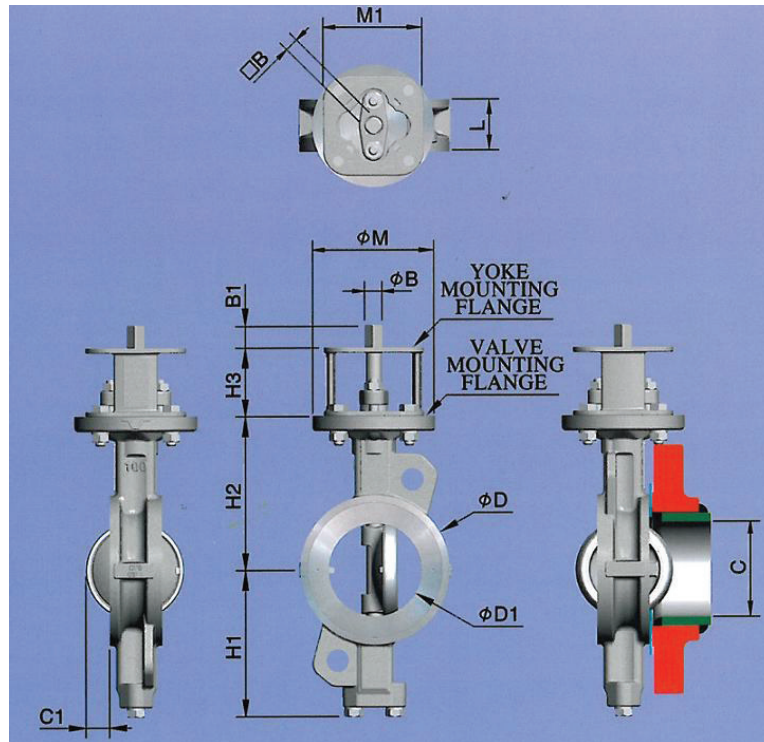
1113-1114 BUTTERFLY VALVES + NA ELECTRIC ACTUATOR
DIMENSIONS (mm)

DN	L	H1	H2	H3	Ø D	Ø D1	C	C1	Weight (Kg)
50	43	99	118	60	92	57	49	2	3.9
65	46	110	125	60	108	63	62	15	4.5
80	47	128	140	70	126	78	78	22	7
100	53	150	157	70	153	95	93	25	9
125	57	163	170	70	184	118	120	36	12
150	56	176	185	70	212	143	149	50	13.5
200	62	206	220	80	268	188	196	70	22
250	68	238	260	80	326	236	243	90	32
300	78	269	290	100	375	282	289	106	48

FLOW FACTOR Kv (m³/h)

DN	50	65	80	100	125	150	200	250	300
Kv	56	119	222	358	615	1709	1709	2649	4059

The following data is for information purpose only and may be subject to alteration without prior notice

1113-1114 BUTTERFLY VALVES + NA ELECTRIC ACTUATOR

ACTUATION WITH NA

Suggested standard NA actuation under the following conditions:

- Electric actuator with an IP 67 epoxy coated aluminium enclosure and steel gears
- A minimum 1.3 safety factor compared with the valve nominal torque rating
- A maximum pressure differential up/downstream of 10 bar (=ΔP)





The actuator is mounted with steel bracket and coupler

DN	Actuator	Power	Operating Time*	Standard equipment of the actuator
50	NA06	15 W	17 s	2 adjustable limit switches + 2 dry auxiliary switches 20 W anti-condensation heater Visual position indicator Actuator thermal cut-out (NA06 and NA09) Torque limiter (NA15 to NA38) Electrical connection: 2 gland packs M20 x 1.5 Manual override by declutchable handwheel
65	NA06	15 W	17 s	
80	NA09	25 W	17 s	
100	NA09	25 W	17 s	
125	NA15	40 W	20 s	
150	NA28	40 W	24 s	
200	NA28	40 W	24 s	
250	NA38	60 W	24 s	
300	NA38	60 W	24 s	

*Unloaded operating time given for information purpose only. May vary depending on the medium
 For any other working conditions, please contact us.

ACTUATION OPTIONS

There are many different options, please contact our commercial department.

1	2	3	4	5
NALCU: Actuator with a local control	NAPCU: regulation actuator 4-20 mA or 0-10 V	NARBP: Safety actuator with an integrated battery emergency shutdown	NA-X: Actuator for use in ATEX zones 1 and 2	SR: Safety spring return actuator
				
6	Electric actuator sized for a maximum pressure differential up/downstream over 10 bar (=ΔP)			
7	NA electric actuator with a declutchable manual override by handwheel			
VALVE OPTIONS				
1	Locating holes drilling according to EN 1092-1 standard for PN16 flanges and according to ANSI B16.5 standard for ANSI 150			
2	Lug connections			

ATEX ZONES INSTALLATION

It is compulsory to specify if the installation of the automatic valve 1113-1114+NA-X will take place in ATEX zones 1 or 2 while making the order. Our services will proceed to the mounting check, to a grounding strip installation and will edit a mounting certificate. Those operations are performed by our proper engineers. Please contact us for further details. It is also compulsory to follow the ATEX zone mounting and maintenance special instructions for motorized valves. The ATEX gland packs and sealing plugs are not provided. Please use the following codes:

ATEX aluminium gland pack M20x1.5	Code 980179	ATEX aluminium sealing plugs M20x1.5	Code 980180
-----------------------------------	-------------	--------------------------------------	-------------

The following data is for information purpose only and may be subject to alteration without prior notice