



## ALL POSITIONS CAST IRON CHECK VALVE PN16

Model/Ref: 363 - 366



*Partnership.  
Without Limits.*

[www.lauridsenindustri.dk](http://www.lauridsenindustri.dk)

**ALL POSITIONS CAST IRON CHECK VALVE PN16**



**Size :** DN 50 to 600  
**Ends :** Flanges R.F. ISO PN10/16  
**Min Temperature :** - 10°C  
**Max Temperature :** + 130°C  
**Max Pressure :** 16 Bars up to DN300 ( 10 bars over )  
**Specifications :** Ductile iron disc  
All positions  
Low head loss

**Materials :** Cast iron body

ALL POSITIONS CAST IRON CHECK VALVE PN16

**SPECIFICATIONS :**

- All positions thanks to the stainless steel spring
- Respect the flow direction indicated by an arrow on the body
- Flanges R.F. ISO PN10/16 up to DN150, ISO PN16 from DN200 to DN300, ISO PN10 over
- With steel strainer basket and 6 mm mesh ( Ref. 363 )
- Weak head loss thanks to the cylindrical internal designing
- Anti-corrosion epoxy internal and external painting blue color RAL 5017, 100 μ thickness
- Bronze bushing to avoid blocking of the disc
- Drilled boss on request for bypass or to check the thickness
- Disc designed for a better hydrodynamism
- Silent solution
- Minimum back pressure for tightness : 0.2 bars

**USE :**

- Water distribution
- Min Temperature Ts : - 10°C
- Max Temperature Ts :+ 130°C
- Max Pressure Ps : 16 bars up to DN300, 10 bars over

**HEAD LOSS GRAPH :**

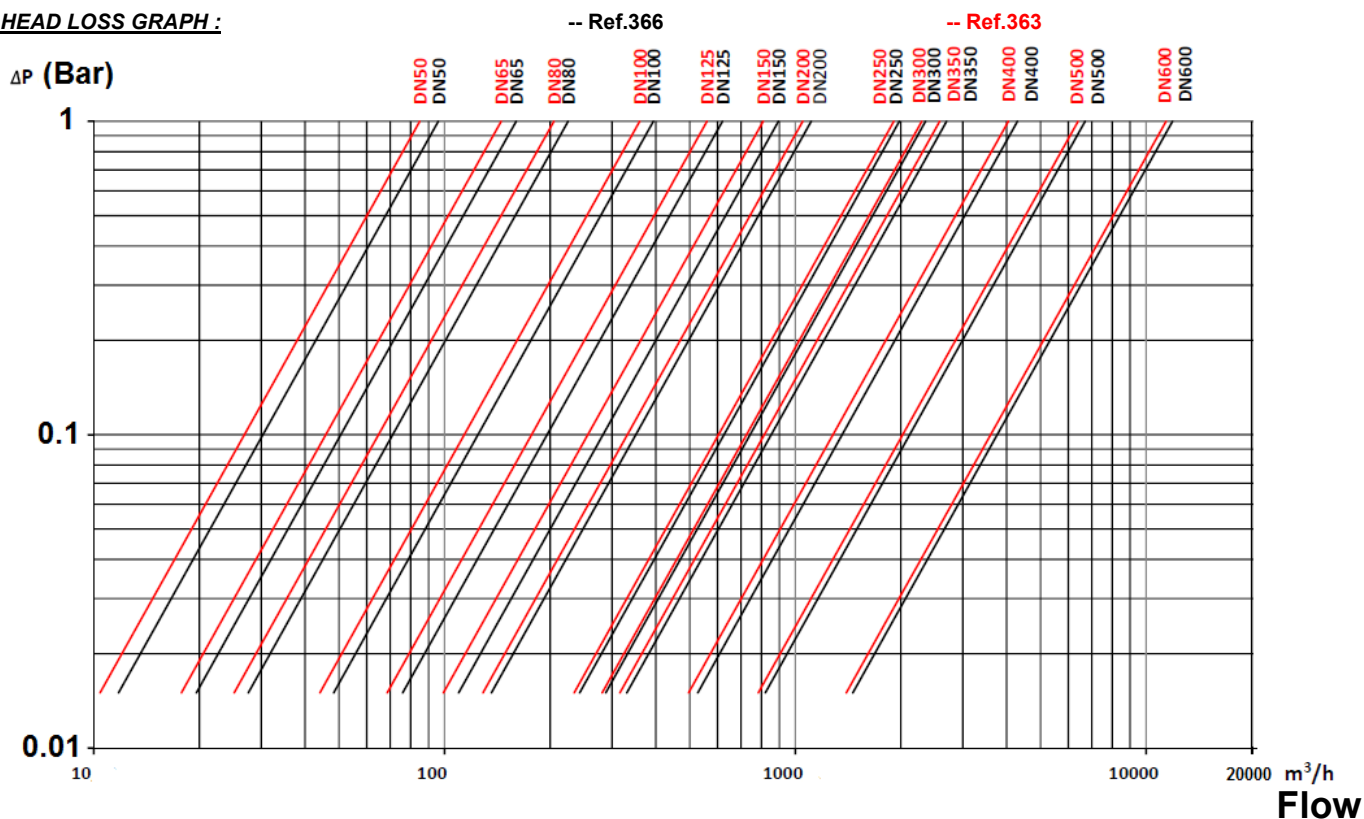

**FLOW COEFFICIENT Kvs ( in m3/h ) :**

Ref.	DN	50	65	80	100	125	150	200	250	300	350	400	500	600
366	Kvs (m3/h)	96	160	225	394	620	895	1110	1980	2350	2700	4300	6700	10750
363	Kvs (m3/h)	86	143	201	351	553	801	980	1750	2115	-	-	-	-

**ALL POSITIONS CAST IRON CHECK VALVE PN16**
**RANGE :**

- Flanged ISO PN10/16 from DN50 to DN 150, ISO PN16 from DN 200 to DN 300 and ISO PN10 for DN350 to 600 **Ref. 366**
- Flanged ISO PN10/16 from DN50 to DN 150 and ISO PN16 from DN 200 to DN 300 with steel strainer basket **Ref. 363**

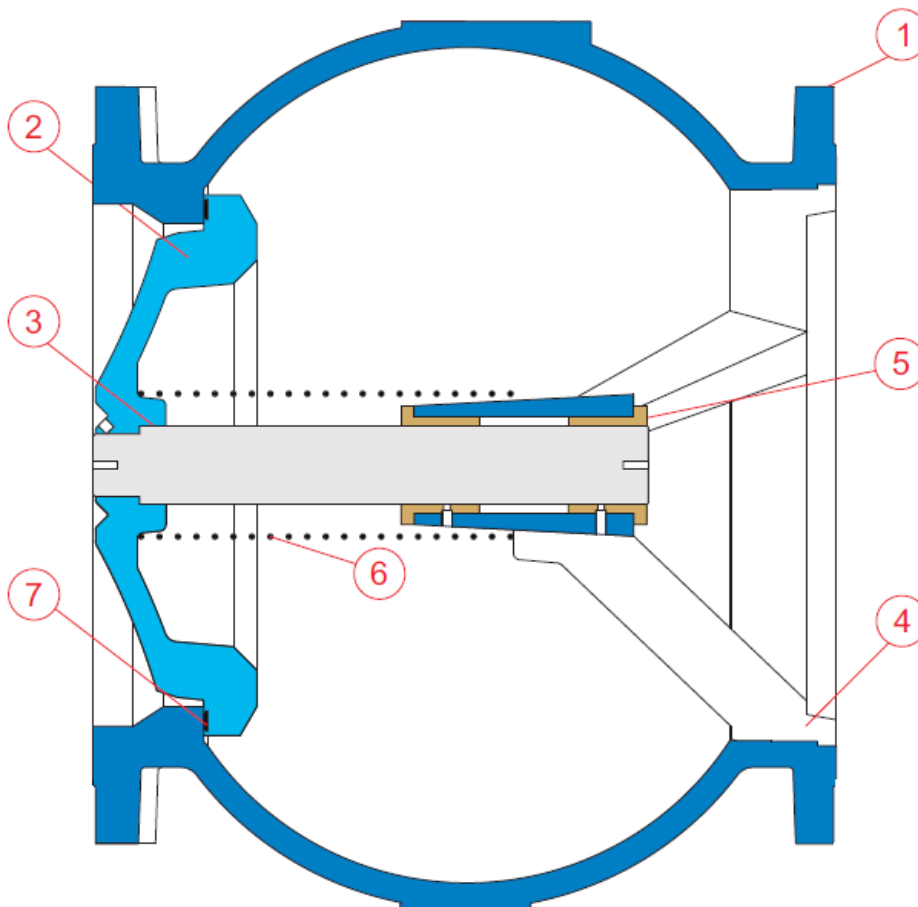
**MATERIALS DN 50 - 300 :**

Item	Designation	Materials
1	Body	Cast iron EN-GJL-250
2	Disc	Ductile iron EN-GJS-400-15
3	Stem	SS 304
4	Guide	Ductile iron EN-GJS-400-15
5	Bushing	Bronze
6	Spring	SS 302
7	Gasket	EPDM

**ALL POSITIONS CAST IRON CHECK VALVE PN16**

MATERIALS DN 350 -600 :

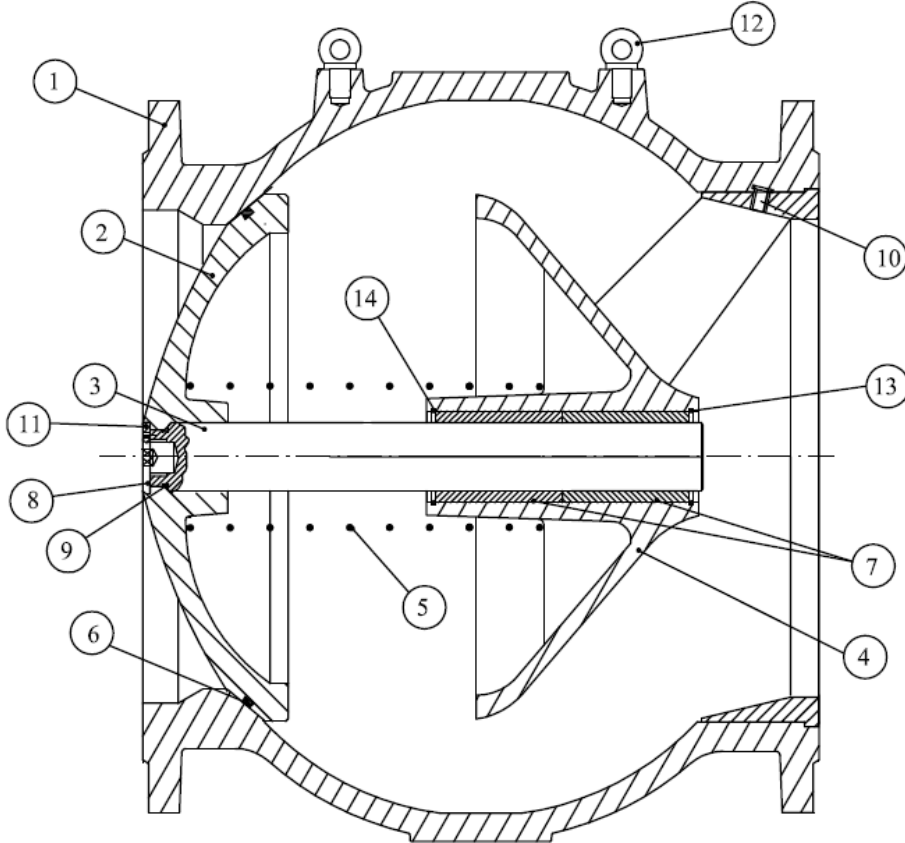

Item	Designation	Materials
1	Body	Ductile iron EN-GJS-400-15
2	Disc	Ductile iron EN-GJS-400-15
3	Stem	SS 316
4	Guide	Ductile iron EN-GJS-400-15
5	Spring	SS 302
6	Gasket	EPDM
7	Bushing	Bronze
8	Cap	Steel
9	O ring	EPDM
10	Pin DIN 916	SS 304
11	Pin DIN 913	SS 304
12	Lifting plug	Steel
13	Circlip	SS 302
14	Circlip	SS 302

**ALL POSITIONS CAST IRON CHECK VALVE PN16**

SIZE REF.366 DN 50 - 300 ( in mm ) :

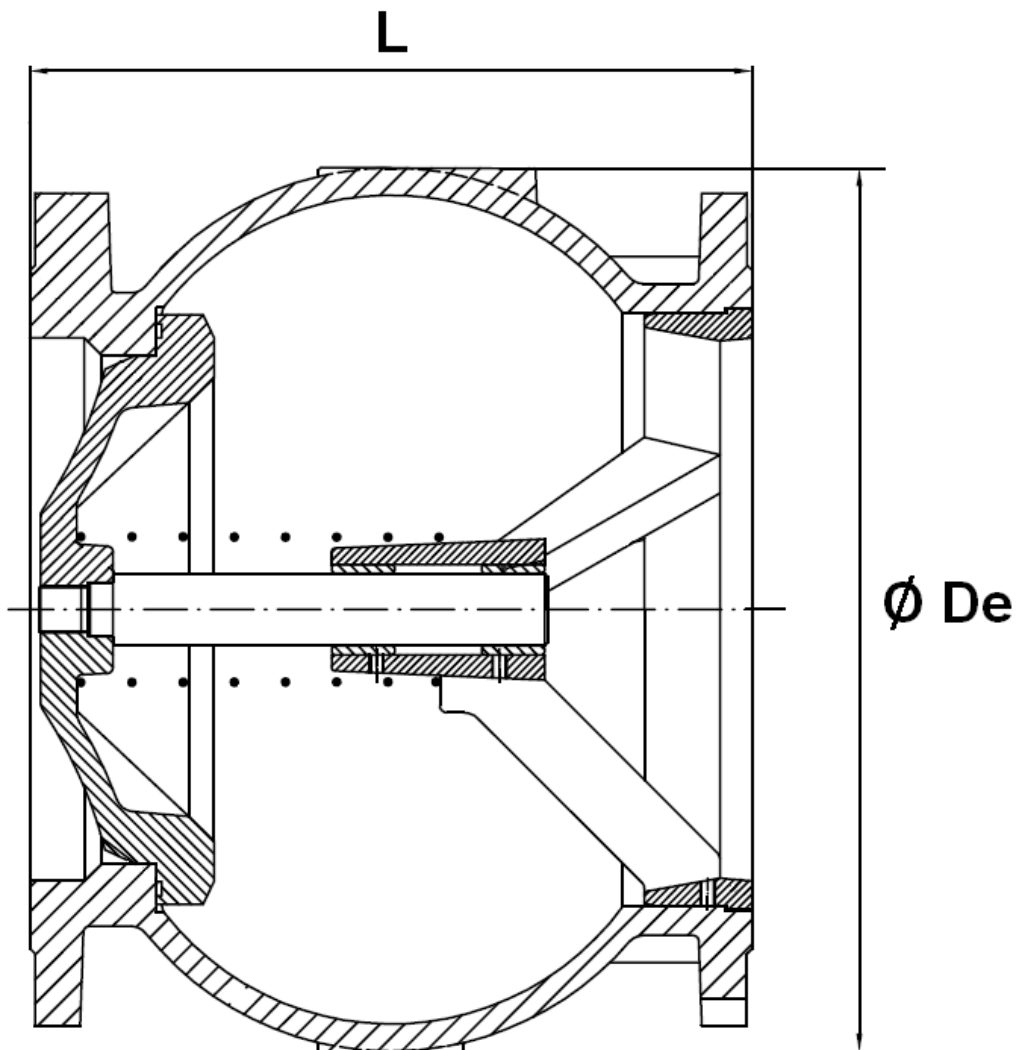

Ref.	DN	50	65	80	100	125	150	200	250	300
366	L	100	120	140	165	195	230	290	355	400
	De	104	127	157	180	215	250	335	410	486
	Weight ( Kg )	5.42	8.22	10.13	13.53	19.5	27.07	46.8	77.2	128



**ALL POSITIONS CAST IRON CHECK VALVE PN16**

SIZE REF. 366 DN 350 – 600 ( in mm ) :

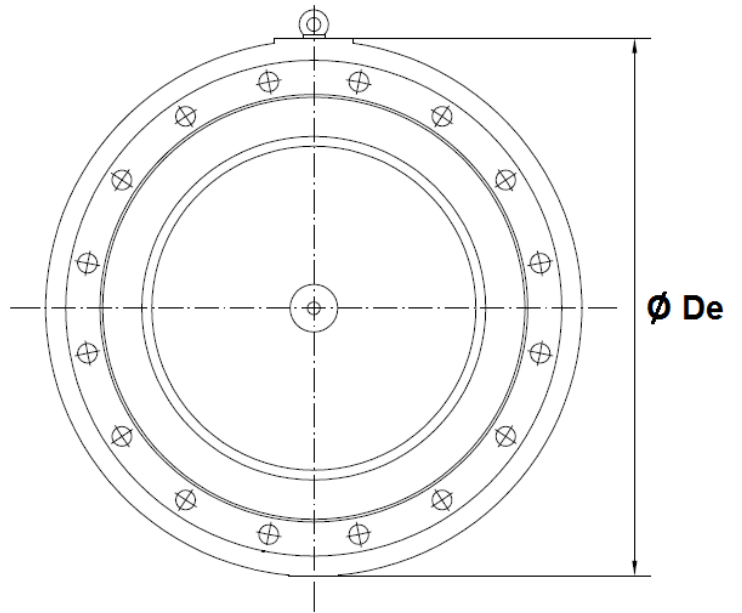
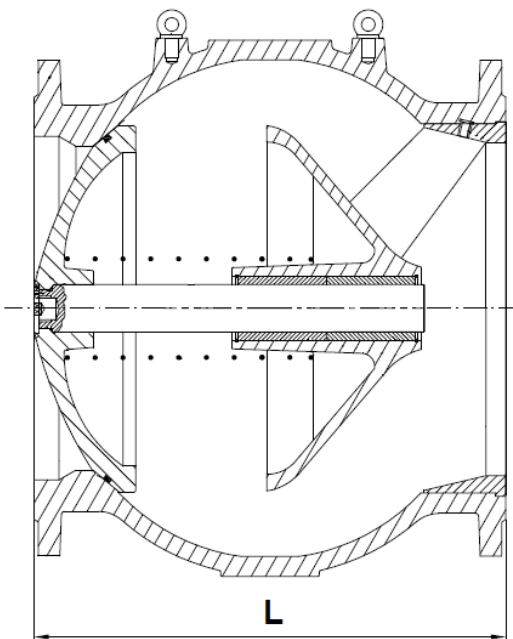

Ref.	DN	350	400	500	600
366	L	480	550	680	800
	Ø De	550	620	780	880
	Weight (in Kg)	260	260	500	780

**ALL POSITIONS CAST IRON CHECK VALVE PN16**

SIZE REF.363 ( in mm ) :

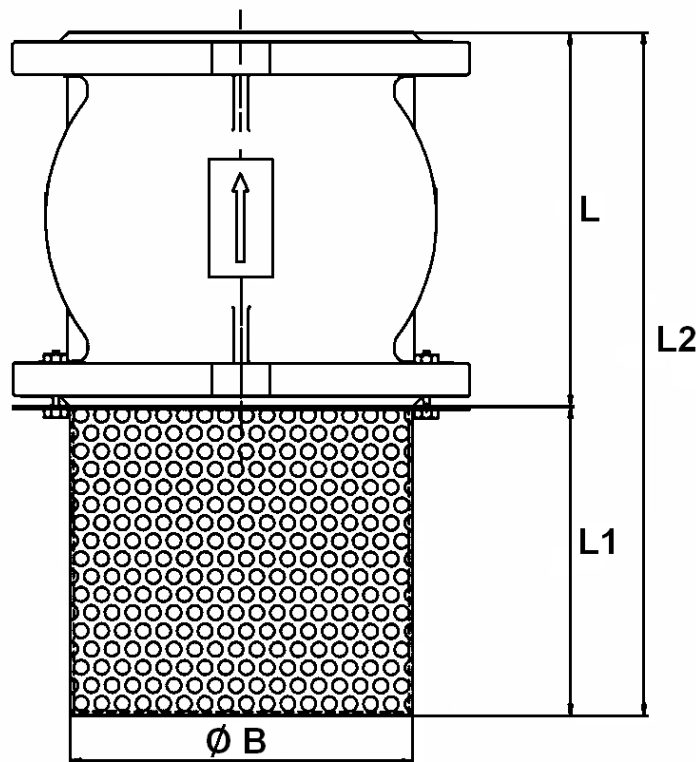

REF.	DN	50	65	80	100	125	150	200	250	300
363	L	100	120	140	165	195	230	290	355	400
	L1	77	110	125	155	170	220	300	390	410
	L2	177	230	265	320	365	450	590	745	810
	Ø B	93	113	128	148	178	200	255	310	360
	Mesh	6	6	6	6	6	6	6	6	6
	Weight ( Kg )	6.01	8.98	10.95	14.73	21	28.88	49.58	81.58	133.38



**ALL POSITIONS CAST IRON CHECK VALVE PN16**

*FLANGES SIZE REF.366 ( in mm ) :*

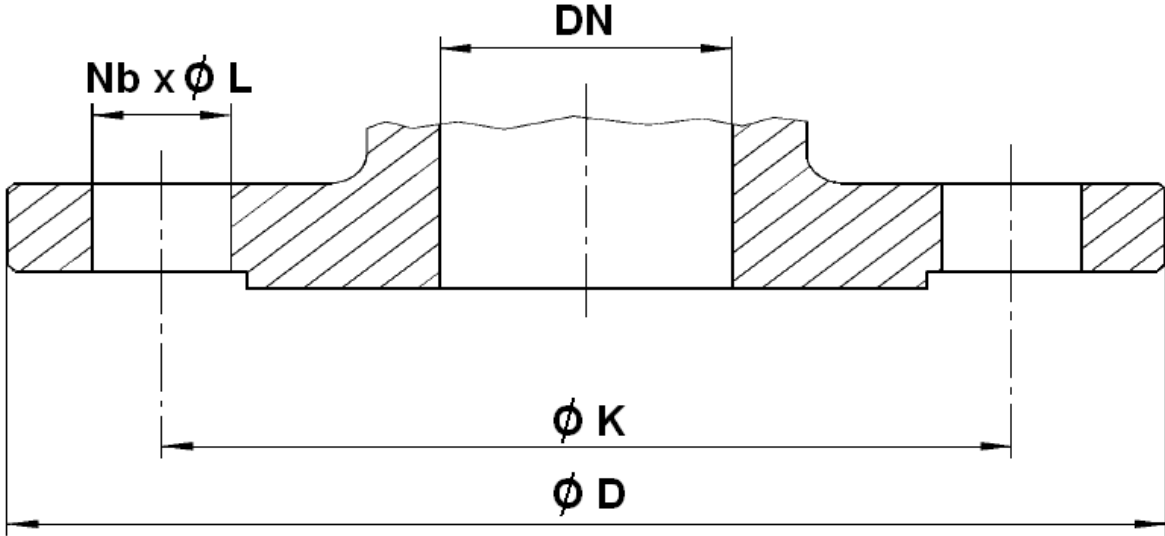

Ref.	DN	50	65	80	100	125	150	200	250	300	350	400	500	600
366	Ø D	165	185	200	220	250	285	340	405	460	505	565	670	780
	Ø K	125	145	160	180	210	240	295	355	410	460	515	620	725
	Nb x Ø L	4 x 19	4 x 19	8 x 19	8 x 19	8 x 19	8 x 23	12 x 23	12 x 28	12 x 28	16 x 23	16 x 27	20 x 26	20 x 30

**ALL POSITIONS CAST IRON CHECK VALVE PN16**
OPENING PRESSURE ( mbar ) :

DN	Vertical Position ascending fluid	Horizontal Position
DN 50	55 ↑	40 →
DN 65	52 ↑	35 →
DN 80	52 ↑	34 →
DN 100	53 ↑	35 →
DN 125	65 ↑	46 →
DN 150	66 ↑	48 →
DN 200	76 ↑	55 →
DN 250	91 ↑	62 →
DN 300	90 ↑	58 →
DN 350	91 ↑	59 →
DN 400	106 ↑	70 →
DN 500	114 ↑	72 →
DN 600	155 ↑	92 →

STANDARDS :

- Fabrication according to ISO 9001: 2008
- DIRECTIVE 97/23/CE : Concerned by article 3, § 3
- French water agreement **A.C.S. N° 10 ACC LY 463** up to DN300
- Tests according to ISO 5208, range A
- Flanges according to EN 1092-2 PN10-PN16

**ALL POSITIONS CAST IRON CHECK VALVE PN16****INSTALLATION INSTRUCTIONS****GENERAL GUIDELINES :**

- Ensure that the check valves to be used are appropriate for the conditions of the installation (type of fluid, pressure and temperature).
- Be sure to have enough valves to be able to isolate the sections of piping as well as the appropriate equipment for maintenance and repair.
- Ensure that the valves to be installed are of correct strength to be able to support the capacity of their usage.

**INSTALLATION INSTRUCTIONS :**

- **Before installing the check valves, clean and remove any objects from the pipes** (in particular bits of sealing and metal) which could obstruct and block the valves.
- **Ensure that both connecting pipes either side of the check valve (upstream and downstream) are aligned** (if they're not, the valves may not work correctly).
- **Make sure that the two sections of the pipe (upstream and downstream) match, the check valve unit will not absorb any gaps. Any distortions in the pipes may affect the tightness of the connection, the working of the check valve and can even cause a rupture.** To be sure, place the kit in position to ensure the assembling will work.
- **If sections of piping do not have their final support in place, they should be temporarily fixed. This is to avoid unnecessary strain on the check valve.**
- If there is a direction changing or if there's another material, it's better to take away the check valve so that it is outside the turbulence area ( **between 3 and 5 times the ND before and after** ).
- After a pump please refer to norm NF CR 13932 to install the check valve.