



THREADED BALL CHECK VALVE PN10

Model/Ref: 335



*Partnership.
Without Limits.*

www.lauridsenindustri.dk

THREADED BALL CHECK VALVE PN10



Size : DN 1" to 3"
Ends : Threaded female BSP
Min Temperature : - 10°C
Max Temperature : + 70°C
Max Pressure : 10 Bars
Specifications : Ball type
Vertical or horizontal installation
Removable bonnet

Materials : Cast iron

THREADED BALL CHECK VALVE PN10

SPECIFICATIONS :

- Ball type
- Vertical with ascendant fluid or horizontal (respect the flow direction indicated by the arrow)
- Female / female
- Removable bonnet for easy maintenance
- Anti-corrosion epoxy painting RAL 5017 blue color 150 microns thickness
- Anti-corrosion stainless steel bolting
- Aluminium NBR coated ball non floating
- Full bore
- Minimum backpressure for tightness between 0.3 and 0.5 bars

USE :

- Water distribution and watering
- Min Temperature Ts : - 10°C
- Max Temperature Ts :+ 70°C
- Max Pressure PN : 10 bars

HEAD LOSS :

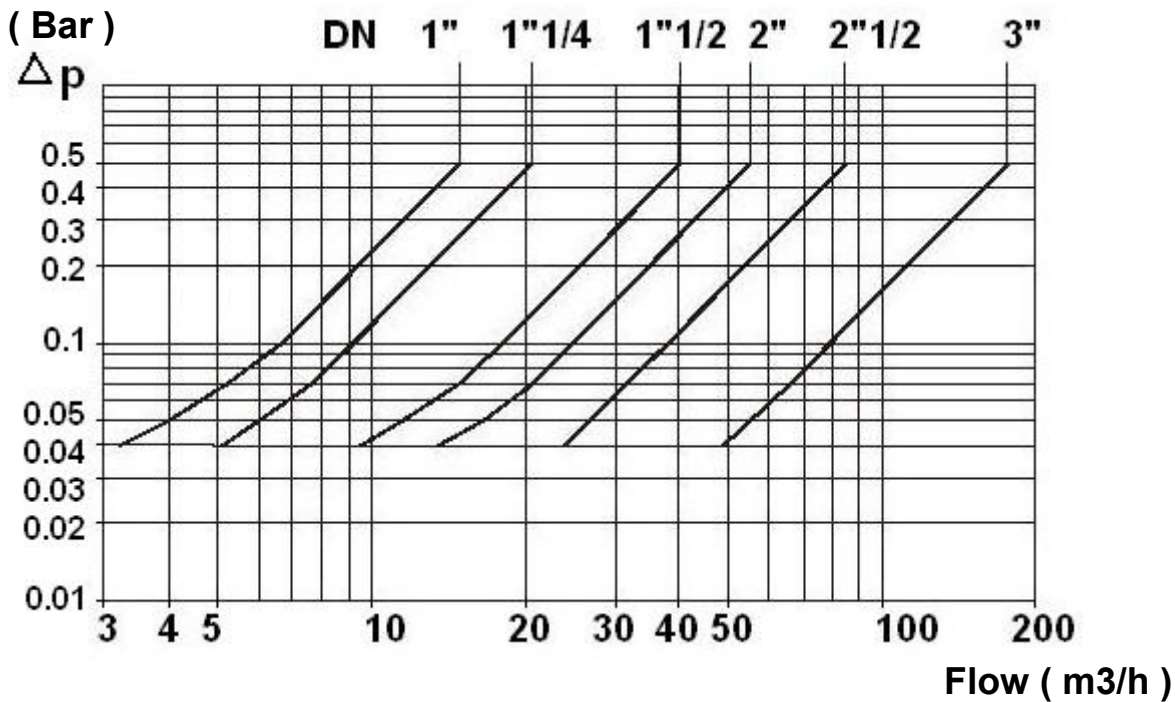

FLOW COEFFICIENT Kvs (in m3/h) :

DN	1"	1 1/4"	1 1/2"	2"	2 1/2"	3"
Kvs (m3/h)	21	29	57	78	120	250

THREADED BALL CHECK VALVE PN10
RANGE :

- Female / female threaded cylindrical BSP Ref. 335 DN1" to 3"

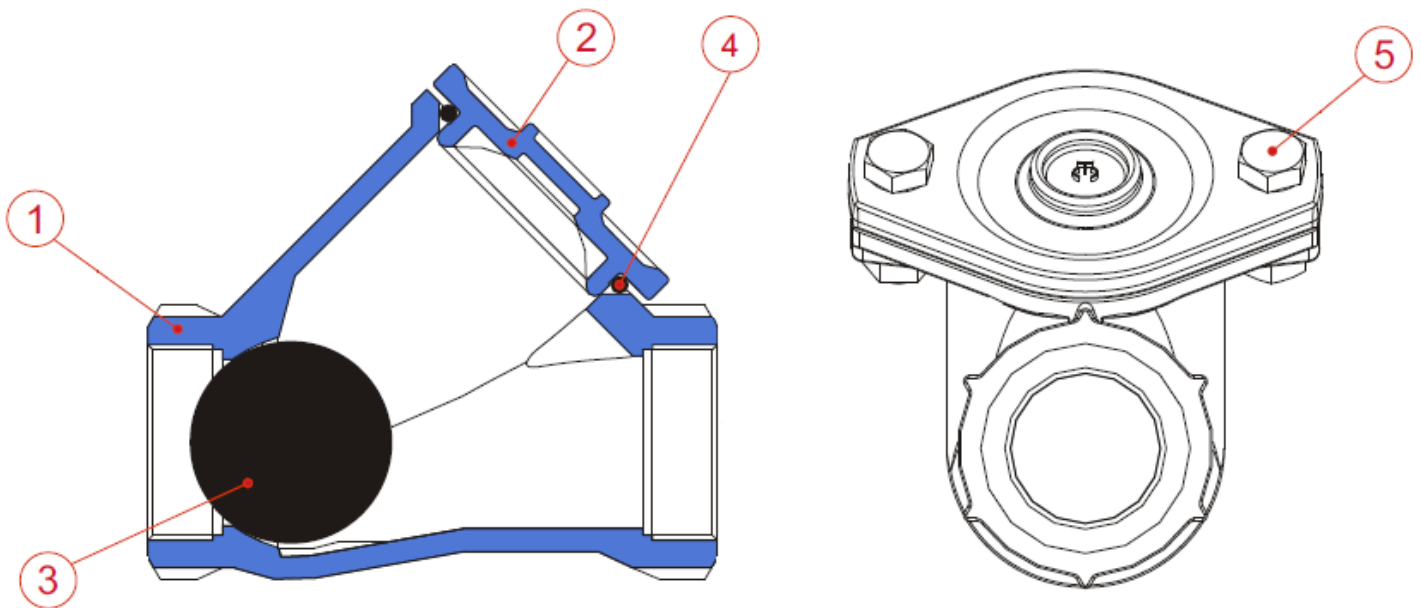
MATERIALS :

Item	Designation	Materials
1	Body	Cast iron EN-GJL-250
2	Bonnet	Cast iron EN-GJL-250
3	Ball	Aluminium + NBR
4	Bonnet gasket	NBR
5	Bolting	SS A-2

THREADED BALL CHECK VALVE PN10

SIZE (in mm) :

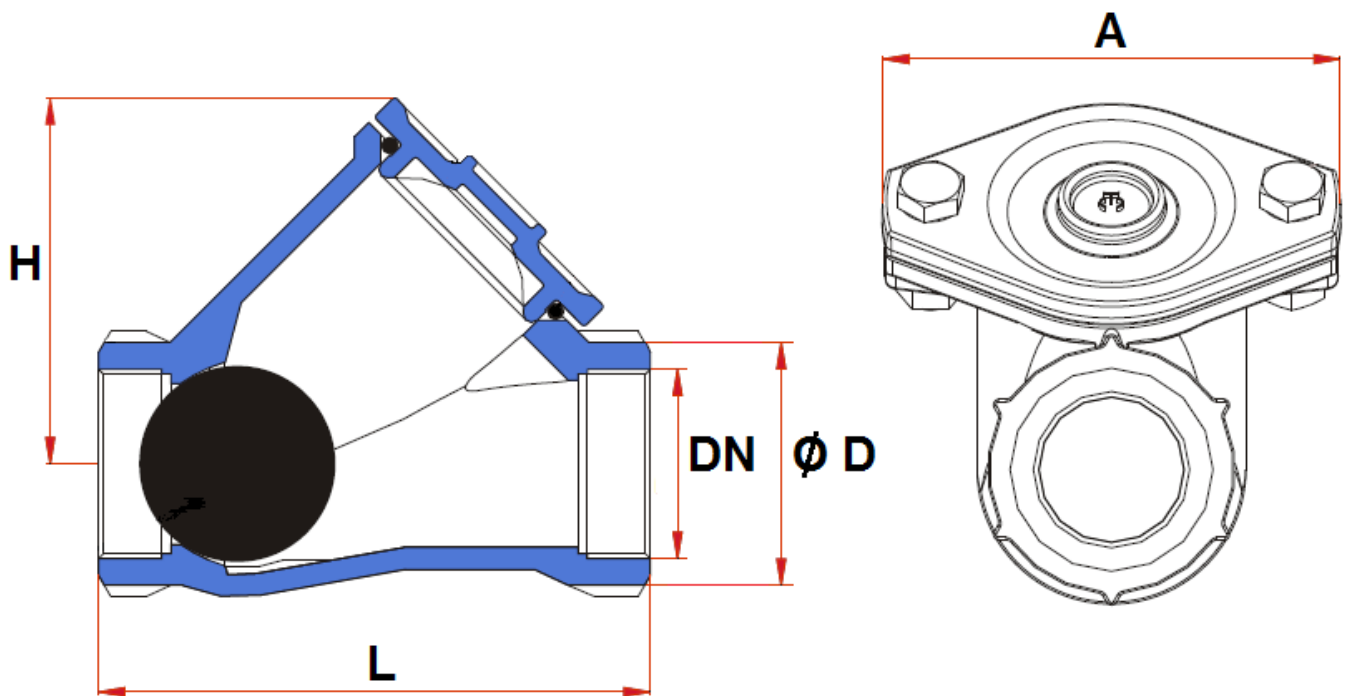

Ref.	DN	1"	1"1/4	1"1/2	2"	2"1/2	3"
335	L	141	141	150	175	214	248
	H	85	85	90	115	135	160
	A	110	110	120	140	155	185
	Ø D	57	57	64	77	95	108
	Weight (Kg)	2.28	2.15	3.05	3.8	6.65	9.15

THREADED BALL CHECK VALVE PN10**STANDARDS :**

- Fabrication according to ISO 9001: 2008
- DIRECTIVE 97/23/CE : Products excluded from directive (Article1, § 3.2)
- Tests according to ISO 5208 A category
- Threaded cylindrical female BSP ends according to ISO 228-1 and NFE 03-005
- According to water pumping stations NF EN 12050-4

INSTALLATION POSITIONS :

Vertical position (Ascendant fluid)

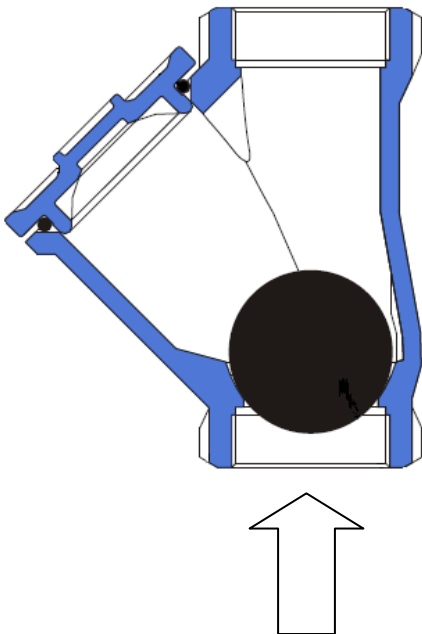

Horizontal position

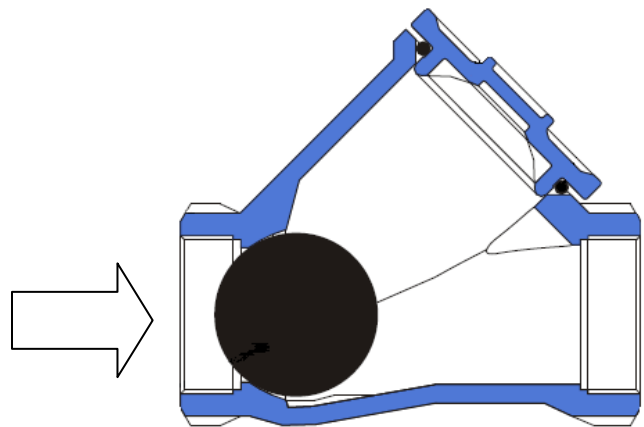

ADVICE :Our opinion and our advice are not guaranteed and Lauridsen Industri shall not be liable for the consequences of damages.

The customer must check the right choice of the products with the real service conditions.

THREADED BALL CHECK VALVE PN10**INSTALLATION INSTRUCTIONS****GENERAL GUIDELINES :**

- Ensure that the check valves to be used are appropriate for the conditions of the installation (type of fluid, pressure and temperature).
- Be sure to have enough valves to be able to isolate the sections of piping as well as the appropriate equipment for maintenance and repair.
- Ensure that the valves to be installed are of correct strength to be able to support the capacity of their usage.

INSTALLATION INSTRUCTIONS :

- **Before installing the check valves, clean and remove any objects from the pipes** (in particular bits of sealing and metal) which could obstruct and block the valves.
- **Ensure that both connecting pipes either side of the check valve (upstream and downstream) are aligned (if they're not, the valves may not work correctly).**
- **Make sure that the two sections of the pipe (upstream and downstream) match, the check valve unit will not absorb any gaps. Any distortions in the pipes may affect the tightness of the connection, the working of the check valve and can even cause a rupture.** To be sure, place the kit in position to ensure the assembling will work.
- Before starting the fitting, ensure that the threads and tapping are clean.
- **If sections of piping do not have their final support in place, they should be temporarily fixed. This is to avoid unnecessary strain on the check valve.**
- The theoretical lengths given by ISO/R7 for the tapping are typically longer than required, the length of the thread should be limited, and **check that the end of the tube does not press right up to the head of the thread.**
- When screwing the check valve, ensure that you only rotate on screwed side by the 6 ended side. Use an open ended spanner or an adjustable spanner and not a monkey wrench.
- **Never use a vice to tighten the fixings of the check valve.**
- Do not over tighten the check valve. Do not block with any extensions as it may cause a rupture or weakening of the casing.
- If there is a direction changing or if there's another material, it's better to take away the check valve so that it is outside the turbulence area (**between 3 and 5 times the ND before and after**).
- After a pump please refer to norm NF CR 13932 to install the check valve.