

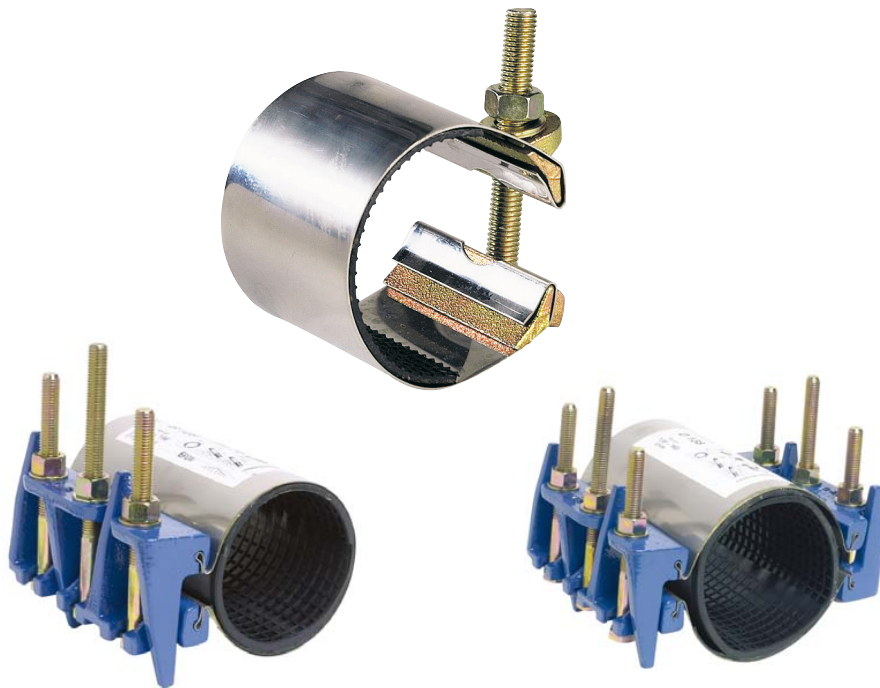

REPAIR CLAMPS

Model/Ref: 1401 -1406



*Partnership.
Without Limits.*

www.lauridsenindustri.dk

REPAIR CLAMPS

ISO 9001:2008
BUREAU VERITAS
Certification



- Size :** DN 21 to DN 516
Ends: For rigid pipes
Min Temperature : - 10°C (with EPDM gasket)
Max Temperature : + 60°C (for temporarily used and EPDM gasket)
Max Pressure : 20 Bars up to DN140
Specifications : EPDM or NBR gasket
SS 304 belt
For PE, PVC, steel and ductile iron pipes

Materials : SS 304 belt

REPAIR CLAMPS

SPECIFICATIONS :

- SS 304 belt
- EPDM or NBR gasket
- For PE, PVC, steel and ductile iron pipes

USE:

- Drinkable water for Ref. 1401, 1403 and 1406 (EPDM)
- Irrigation and sewage systems for Ref. 1405 (NBR)
- Min and max Temperature Ts : - 10°C to + 60°C (for temporarily used) for EPDM gasket types Ref.1401-1403-1406
- Min and max Temperature Ts : + 0°C to + 85°C (for temporarily used) for NBR gasket types Ref.1405
- Max pressure PN : see graph under

DN	20 – 140	141 – 200	201 – 250	251 – 300	301 – 400	401 - 500
PN (Bars)	20	16	10	8	4.5	2.5

RANGE :

- Temporarily repair clamp type M, 1 bolt length 80 mm with EPDM gasket **Ref.1401** from DN 21 to DN 173
- Repairing for complete break type B, 3 bolts, length 200 mm with EPDM gasket **Ref.1403** from DN 48 to DN 285
- Repairing for complete break type B, 3 bolts, length 200 mm with NBR gasket **Ref.1405** from DN 48 to DN 285
- Repairing for complete break type D, 3x2 bolts, length 200 mm with EPDM gasket **Ref.1406** from DN 88 to DN 516

MATERIALS :

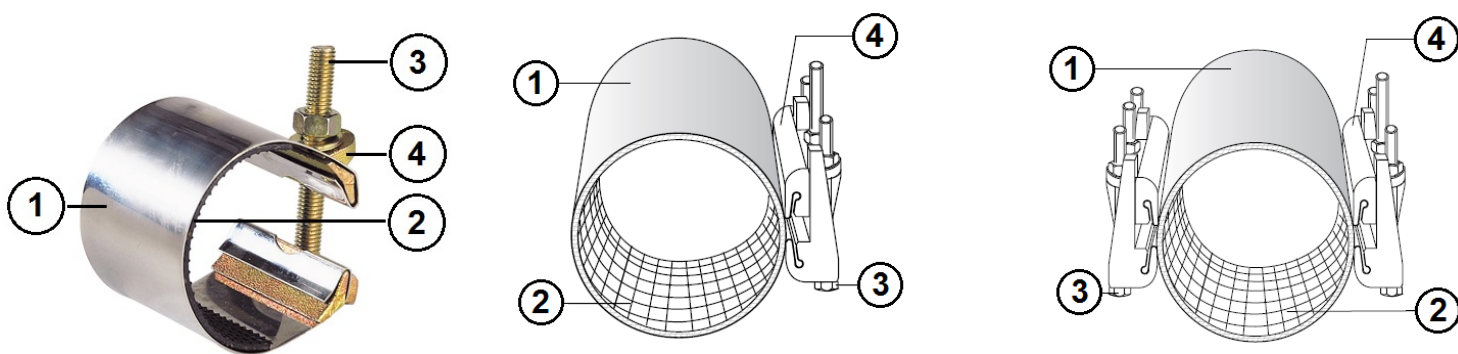

Item	Designation	Materials Ref.1401-1403-1406	Materials Ref.1405
1	Insert	SS 304	SS 304
2	Gasket	EPDM (ACS)	NBR
3	Bolting	Steel 6.S	Steel 6.S
4	Clamp	Ductile iron EN GJS-500-7	Ductile iron EN GJS-500-7

REPAIR CLAMPS
SIZE (in mm) :

Ref. 1401
Type M
1 bolt
Length 80mm

Repairing

Ø external pipe		Pressure PN
Mini	Maxi	
21	25	20 bars
26	30	20 bars
29	33	20 bars
33	37	20 bars
38	42	20 bars
42	45	20 bars
48	51	20 bars
50	54	20 bars
55	60	20 bars
60	64	20 bars
65	69	20 bars
69	73	20 bars
71	76	20 bars
76	82	20 bars
82	87	20 bars
87	93	20 bars
94	100	20 bars
99	104	20 bars
105	111	20 bars
112	118	20 bars
120	126	20 bars
126	131	20 bars
131	136	20 bars
139	145	16 bars
156	162	16 bars
167	173	16 bars

Ref. 1403-1405
Type B
3 bolts
Length 200mm

Repairing for comp. break

Ø external pipe		Pressure PN
Mini	Maxi	
48	56	20 bars
56	64	20 bars
60	68	20 bars
68	78	20 bars
78	88	20 bars
88	98	20 bars
98	108	20 bars
108	118	20 bars
114	126	20 bars
126	138	20 bars
138	150	16 bars
140	153	16 bars
150	162	16 bars
162	174	16 bars
168	182	16 bars
174	186	16 bars
186	198	16 bars
198	210	10 bars
210	223	10 bars
222	234	10 bars
234	246	10 bars
243	255	10 bars
273	285	8 bars

Ref. 1406
Type D (2 pieces)
3 bolts x 2
Length 200mm

Repairing for comp. break

Ø external pipe		Pressure PN
Mini	Maxi	
88	110	20 bars
114	137	20 bars
138	160	20 bars
160	182	20 bars
182	202	20 bars
202	224	16 bars
217	240	16 bars
240	262	16 bars
262	284	10 bars
273	296	10 bars
296	319	8 bars
324	346	8 bars
346	368	8 bars
365	387	8 bars
387	410	4,5 bars
410	432	4,5 bars
428	450	4,5 bars
450	474	4,5 bars
470	492	4,5 bars
492	516	2,5 bars

REPAIR CLAMPS

STANDARDS :

- Fabrication according to ISO 9001 : 2008
- Directive 97/23/CE : Products excluded from directive (Article 1, § 3.2)
- French water agreement **A.C.S. N° 09 MAT NY 062** for types with EPDM gasket **Ref.1401-1403-1406**

ADVICE : Our opinion and our advice are not guaranteed and lauridsen industri shall not be liable for the consequences of damages. The customer must check the right choice of the products with the real service conditions.

INSTALLATION INSTRUCTIONS

1.1 Storage

The equipment has to be stored in covered places, protected from the sun, rain and all other atmospheric agents. Moreover it has to be avoided that the seal comes in contact with dust and dirt.

1.2 Installation

The structure and the construction method allow a good facility and fast assembly of the collar on the pipe to repair.

Here follow are described the operations to carry out during the installation:

1. Clean the part of the pipe to be repair from eventual soil deposits;
2. Position the repair clamp in correspondance with the cut or the hole;
3. Ensure that the tapered end of the gasket is not folded on itself in any point, and that it is well extended on the pipeline to be repaired;

Note: we suggest greasing the tapered end with soapy water, grease or Vaseline.

4. Put the opposite terminal of the clamp on the tapered end.
5. To insert the threaded studs in the respective positions of the buttonholes and manually shut.
6. Rotate the repair clamp in the indicated direction by the arrow printed on the label (indispensable operation for the definitive correct extension of the tapered end) possibly making sure that the damaged section of the pipeline remains under the section of vulcanized plate in the gasket.
7. Uniformly and gradually tighten the three or more screws so that the two clamps come together during the tightening, always parallel to each other according to the recommended tightening torque.

Note: make sure during this phase that the vulcanized welt sheet in the gasket, does not strain and it keeps its preformed bend: if it strains, it will compromise the seal.