



DOUBLE PLATE CHECK VALVE

Model/Ref: 370 - 371 - 372



*Partnership.
Without Limits.*

www.lauridsenindustri.dk

DOUBLE PLATE CHECK VALVE



Size : DN 50 to 600
Ends : Between flanges ISO PN10/16 or ISO PN25
Min Temperature : - 10°C
Max Temperature : + 90°C for NBR, 110°C for EPDM, 200°C for FKM
Max Pressure : 10 to 16 Bars (according to DN)
Specifications : Vulcanized gasket
Horizontal or vertical position
Between flanges

Materials : Cast iron or stainless steel body

DOUBLE PLATE CHECK VALVE

SPECIFICATIONS :

- Vulcanized gasket
- Hoisting eye from DN200 to 600
- Short length
- Anti-corrosion stainless steel spring
- PTFE bushing
- Weak head loss
- Vertical position with ascendant fluid or horizontal position (respect the flow direction indicated by the arrow)
- Between flanges ISO PN10/16 or ISO PN25
- Anti-corrosion epoxy painting RAL003 50-100 microns thickness for body of 370 and 371 types

USE :

- Heating, water distribution for **Ref. 370-371**
- Chemical and pharmaceutical industries, petrochemical industries, hydraulic installation for **Ref. 372**
- Min and max Temperature Ts : - 10°C to + 90°C (110°C temporarily) for cast iron body with NBR gasket type **Ref.370**
- Min and max Temperature Ts : - 10°C to + 110°C for cast iron body with EPDM gasket type **Ref.371**
- Min and max Temperature Ts : - 10°C to + 200°C for stainless steel body with FKM gasket type **Ref.372**
- Max Pressure Ps : 16 bars up to DN300 included and 10 bars over
- **Do not use with pulsatory speed**

HEAD LOSS GRAPH :

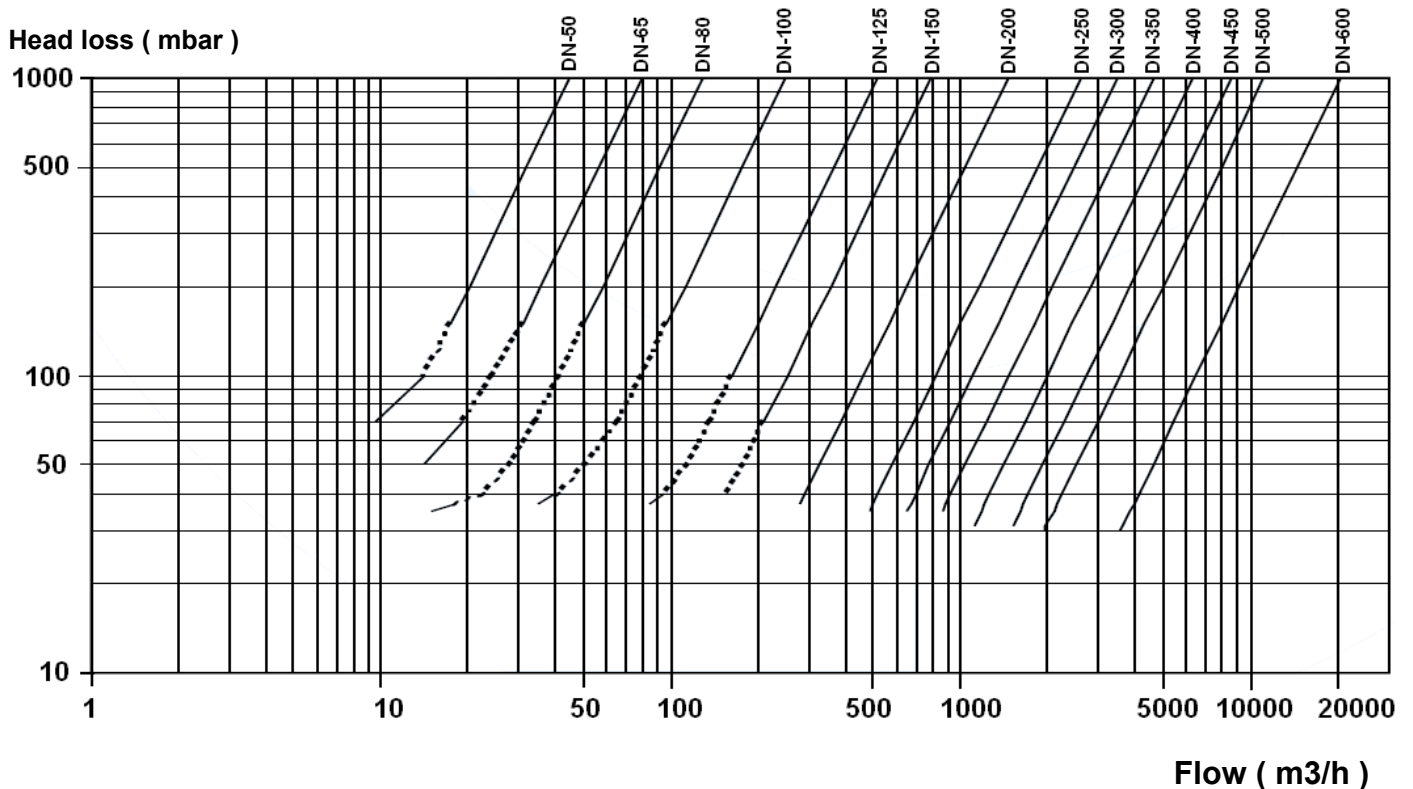

OPENING PRESSURE (in mbar) :

DN	50	65	80	100	125	150	200	250	300
Horizontal position	230	94	190	280	160	79	41	38	31
Vertical position ascend. fluid	260	114	230	320	180	95	57	58	56

DOUBLE PLATE CHECK VALVE

RANGE :

- Double plate check valve with cast iron body and ductile iron disc between flanges ISO PN10/16 **Ref. 370** From DN50 to DN 600
- Double plate check valve with cast iron body and stainless steel disc between flanges ISO PN10/16 **Ref. 371** From DN50 to DN 300
- Double plate check valve with Stainless steel body and disc between flanges ISO PN25 from DN 50 to 200 and ISO PN10/16 from DN 250 to DN 600 **Ref. 372** From DN50 to 600

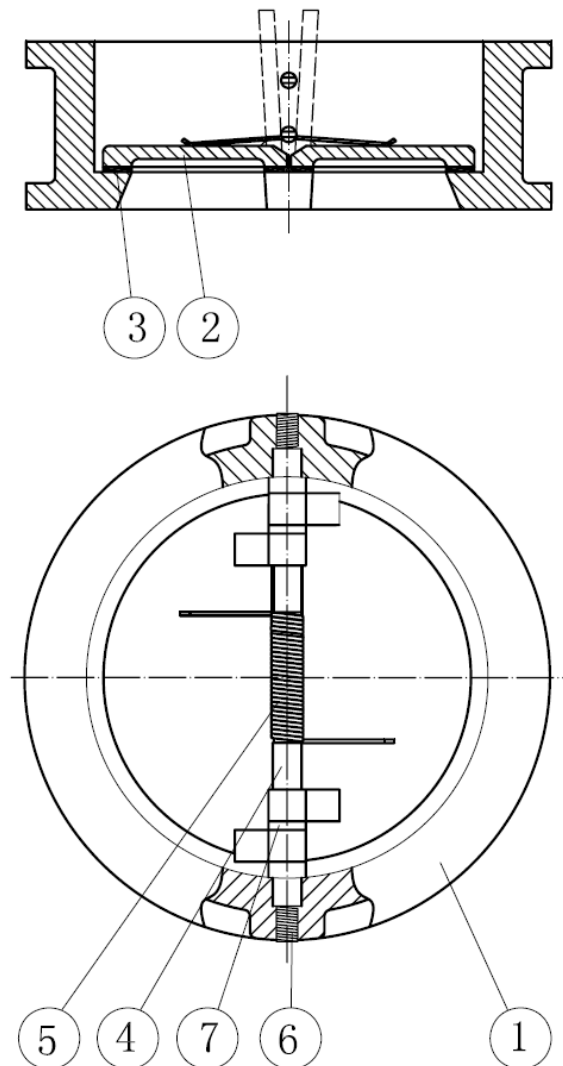
MATERIALS DN50-80 :

Item	Designation	Materials 370	Materials 371	Materials 372
1	Body	Cast iron EN-GJL 250	Cast iron EN-GJL 250	SS ASTM A351 CF8M
2	Disc	Nickel ductile iron EN-GJS 400-15	SS ASTM A351 CF8M	SS ASTM A351 CF8M
3	Seat	NBR	EPDM	FKM
4	Shaft	SS 304	SS 316	SS 316
5	Spring	SS 304	SS 316	SS 316
6	Screw	Galvanized carbon steel	Galvanized carbon steel	SS 316
7	Spacer	PTFE	PTFE	PTFE

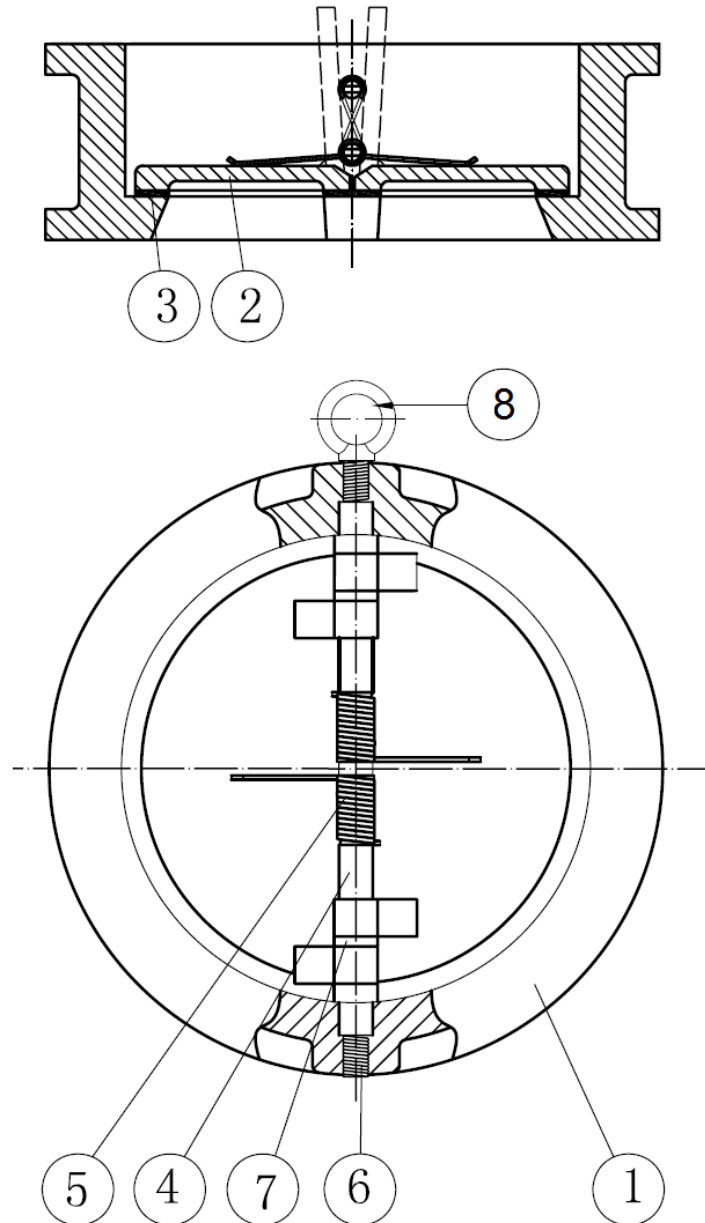
DOUBLE PLATE CHECK VALVE
MATERIALS DN100 - 600 :

Item	Designation	Materials 370	Materials 371	Materials 372
1	Body	Cast iron EN-GJL 250	Cast iron EN-GJL 250	ASTM A351 CF8M
2	Disc	Nickel ductile iron EN-GJS 400-15	ASTM A351 CF8M	ASTM A351 CF8M
3	Seat	NBR	EPDM	FKM
4	Shaft	SS 304	SS 316	SS 316
5	Spring	SS 304	SS 316	SS 316
6	Screw	Galvanized carbon steel	Galvanized carbon steel	SS 316
7	Spacer	PTFE	PTFE	PTFE
8	Hoisting eye (from DN200 to 600)	SS 304	SS 304	SS 304

DOUBLE PLATE CHECK VALVE

SIZE REF.370/371 (in mm):

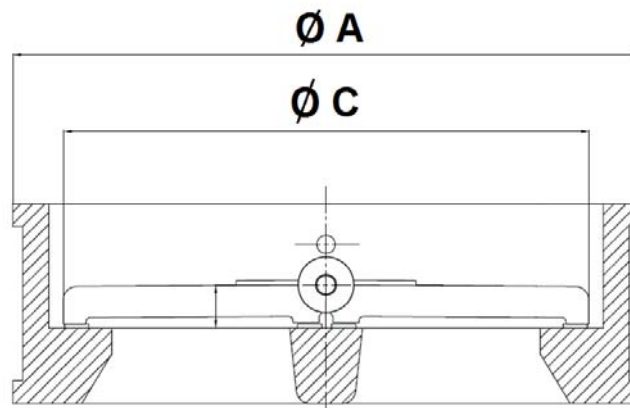
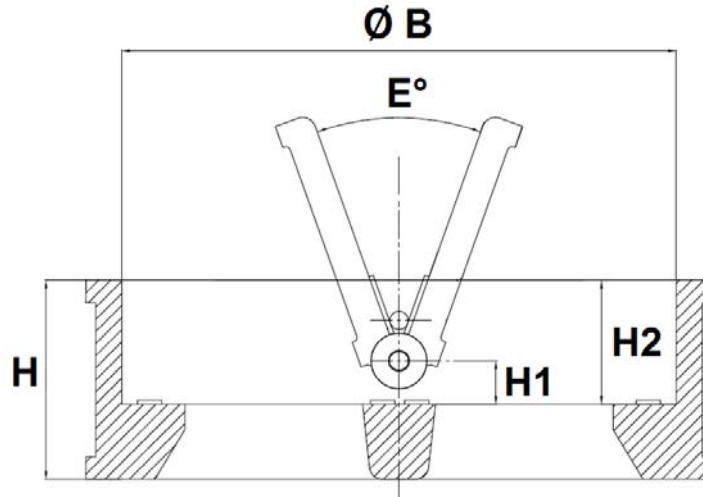

Ref.	DN	50	65	80	100	125	150	200	250	300	350	400	450	500	600	
370/371	H	54	54	57	64	70	76	95	108	144	184	191	203	213	222	
	H1	14.4	16.9	19.9	21	22.3	22.5	28	34	37	35	37.5	42.2	39.5	48.5	
	H2	43	43	45	47	51	54	69	71	100	120	123	122.6	132	138.5	
	Ø A	109	129	144	164	194	220	275	330	380	440	491	541	596	697	
	Ø B	70.5	83.5	91.5	115.5	142.5	169.5	220.5	275.5	325.5	356	406	467	514	616	
	Ø C	59	73	80.8	102.8	126.8	77.4	99.4	125.2	149.2	335	388	430	480	585	
	E°	0°	0°	0°	0°	0°	0°	0°	0°	0°	0°	20°	20°	20°	25°	25°
	Weight (Kg)	1.62	2.3	3.14	4.5	6.7	9.05	16	26.9	38.9	80	106	128	158	225	

DOUBLE PLATE CHECK VALVE

SIZE REF.372 (in mm) :

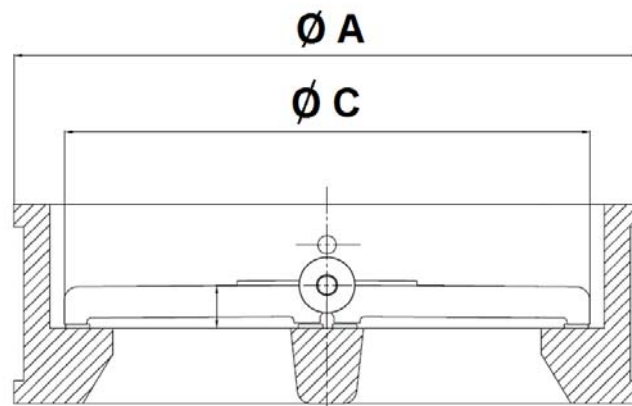
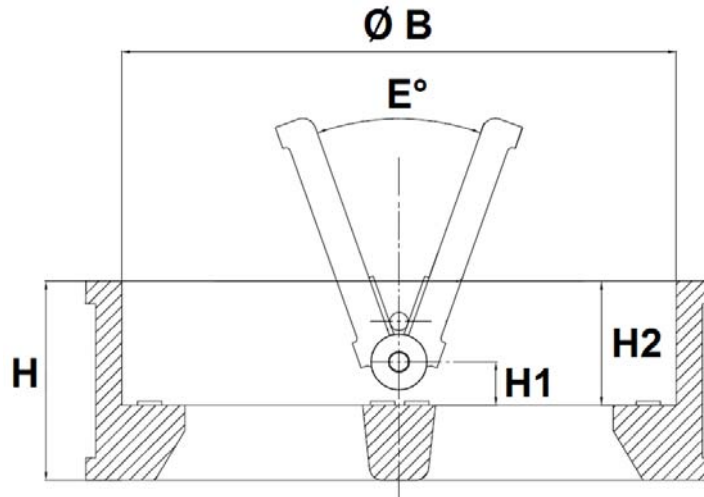

Ref.	DN	50	65	80	100	125	150	200	250	300	350	400	450	500	600
372	H	54	54	57	64	70	76	95	108	144	184	191	203	213	222
	H1	14.4	16.9	19.9	21	22.3	22.5	28	34	37	35	37.5	42.2	39.5	48.5
	H2	43	43	45	47	51	54	69	71	100	120	123	122.6	132	138.5
	Ø A	109	129	144	170	196	226	285	330	380	440	491	541	596	698
	Ø B	70.5	83.5	91.5	115.5	142.5	169.5	220.5	275.5	325.5	356	406	467	514	616
	Ø C	59	73	80.8	102.8	126.8	77.4	99.4	125.2	149.2	335	388	430	480	585
	E°	0°	0°	0°	0°	0°	0°	0°	0°	0°	20°	20°	20°	25°	25°
	Weight (Kg)	1.84	2.4	3.35	5.05	6.68	9.6	18.07	26.9	38.9	80	106	128	158	225

DOUBLE PLATE CHECK VALVE**STANDARDS :**

- Fabrication according to ISO 9001 : 2008
- DIRECTIVE 97/23/CE : Risk Category I Module A
- Designing according to API 594
- Tests according to API 598
- Length according to EN 558 Series 50
- Between flanges according to EN 1092-2 PN10/16 for cast iron check valves Ref.370- 371
- Between flanges according EN 1092-1 PN10/16/25 for stainless steel check valves Ref.372

INSTALLATION POSITIONS :

Vertical position (ascendant fluid)

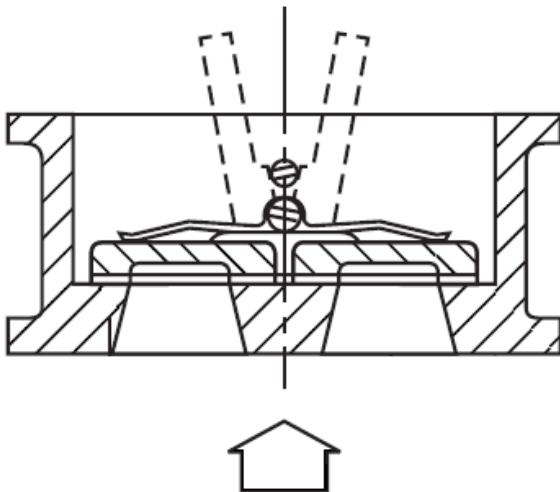

Horizontal position

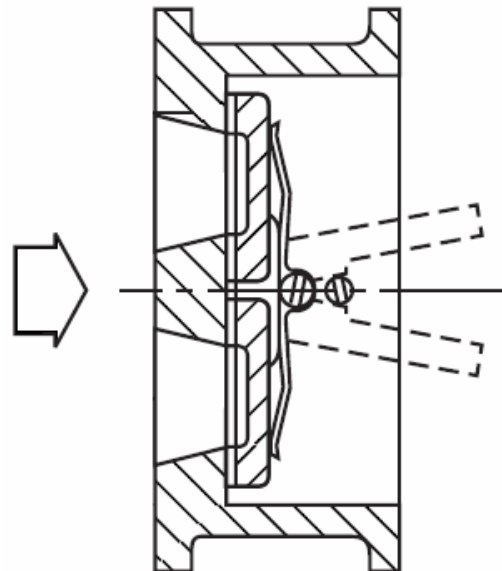

ADVICE :Our opinion and our advice are not guaranteed and Lauridsen Industri shall not be liable for the consequences of damages.

The customer must check the right choice of the products with the real service conditions.

DOUBLE PLATE CHECK VALVE**INSTALLATION INSTRUCTIONS****GENERAL GUIDELINES :**

- Ensure that the check valves to be used are appropriate for the conditions of the installation (type of fluid, pressure and temperature).
- Be sure to have enough valves to be able to isolate the sections of piping as well as the appropriate equipment for maintenance and repair.
- Ensure that the valves to be installed are of correct strength to be able to support the capacity of their usage.

INSTALLATION INSTRUCTIONS :

- **Before installing the check valves, clean and remove any objects from the pipes** (in particular bits of sealing and metal) which could obstruct and block the valves.
- **Ensure that both connecting pipes either side of the check valve (upstream and downstream) are aligned** (if they're not, the valves may not work correctly).
- **Make sure that the two sections of the pipe (upstream and downstream) match, the check valve unit will not absorb any gaps. Any distortions in the pipes may affect the tightness of the connection, the working of the check valve and can even cause a rupture.** To be sure, place the kit in position to ensure the assembling will work.
- Make sure there is enough space so that the disc can be opened totally in the pipe.
- If there is a direction changing or if there's another material, it's better to take away the check valve so that it is outside the turbulence area (**between 3 and 5 times the ND before and after**).
- After a pump please refer to norm NF CR 13932 to install the check valve.