

FLANGED BALL CHECK VALVE PN10



Size : DN 40 to 500
Ends : PN10/16 RF Flanged
Min Temperature : - 10°C
Max Temperature : + 70°C
Max Pressure : 10 Bars
Specifications : Ball type
Vertical or horizontal position
Removable bonnet

Materials : Ductile Iron EN GJS-400-15

FLANGED BALL CHECK VALVE PN10

SPECIFICATIONS :

- Ball type
- Vertical with ascendant fluid or horizontal (respect the flow direction indicated by the arrow)
- PN10/16 RF Flanged up to DN150, PN10 over
- Removable bonnet for easy maintenance
- Anti-corrosion epoxy painting RAL 5017 blue color 150 microns thickness
- Anti-corrosion stainless steel bolting
- Aluminium or ductile iron NBR coated ball non floating
- Full bore
- Minimum backpressure for tightness between 0.3 and 0.5 bars

USE :

- Water distribution and watering
- Min Temperature Ts : - 10°C
- Max Temperature Ts :+ 70°C
- Max Pressure Ps : 10 bars

HEAD LOSS :

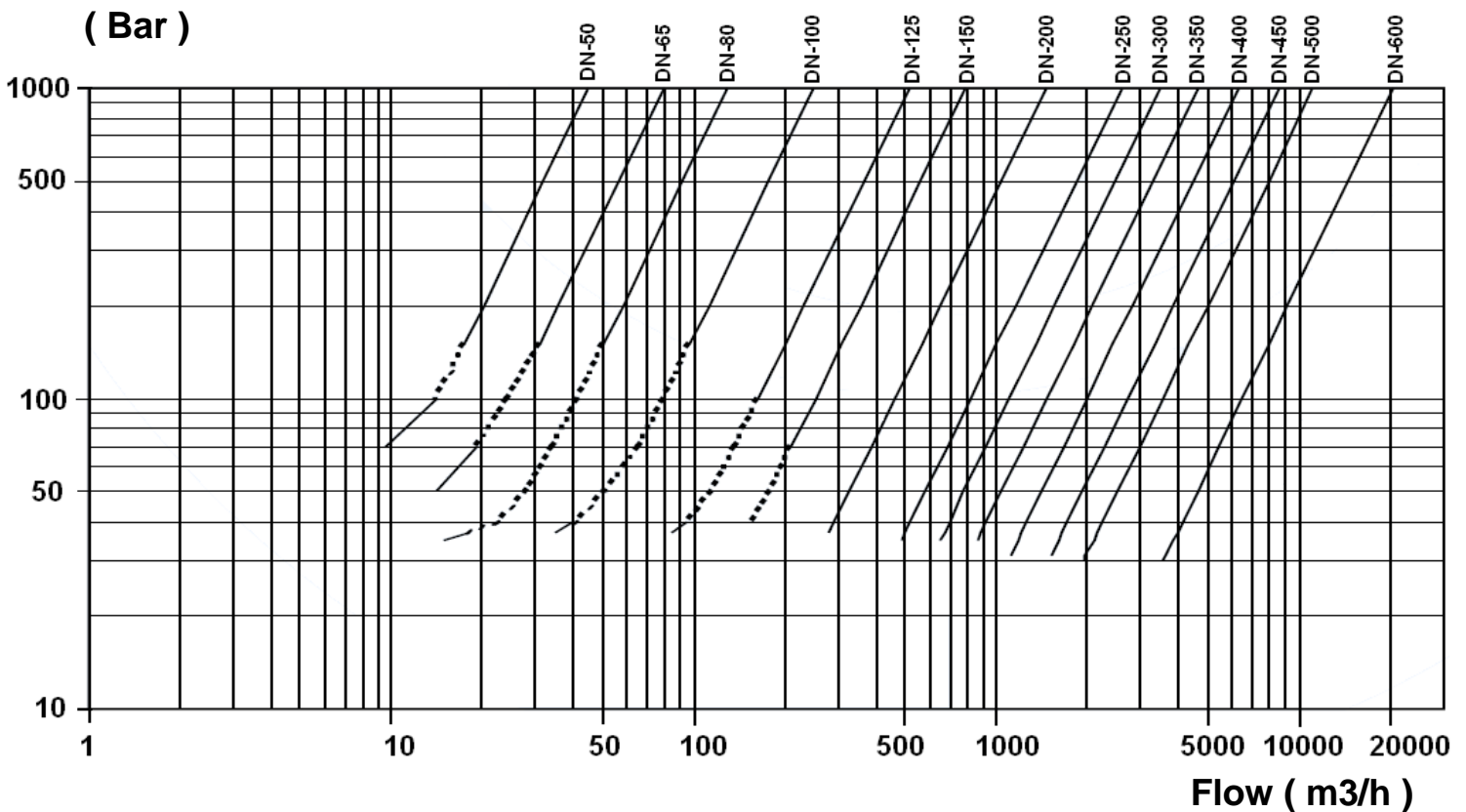

FLOW COEFFICIENT Kvs (in m3/h) :

DN	40	50	65	80	100	125	150	200	250	300	350	400	450	500
Kvs (m3/h)	60	81	130	255	400	645	970	2000	3050	4150	5100	6600	7500	9700

FLANGED BALL CHECK VALVE PN10

RANGE :

- PN10/16 RF Flanged from DN40 to 150 and PN10 over Ref. 336 DN40 to 500

MATERIALS :

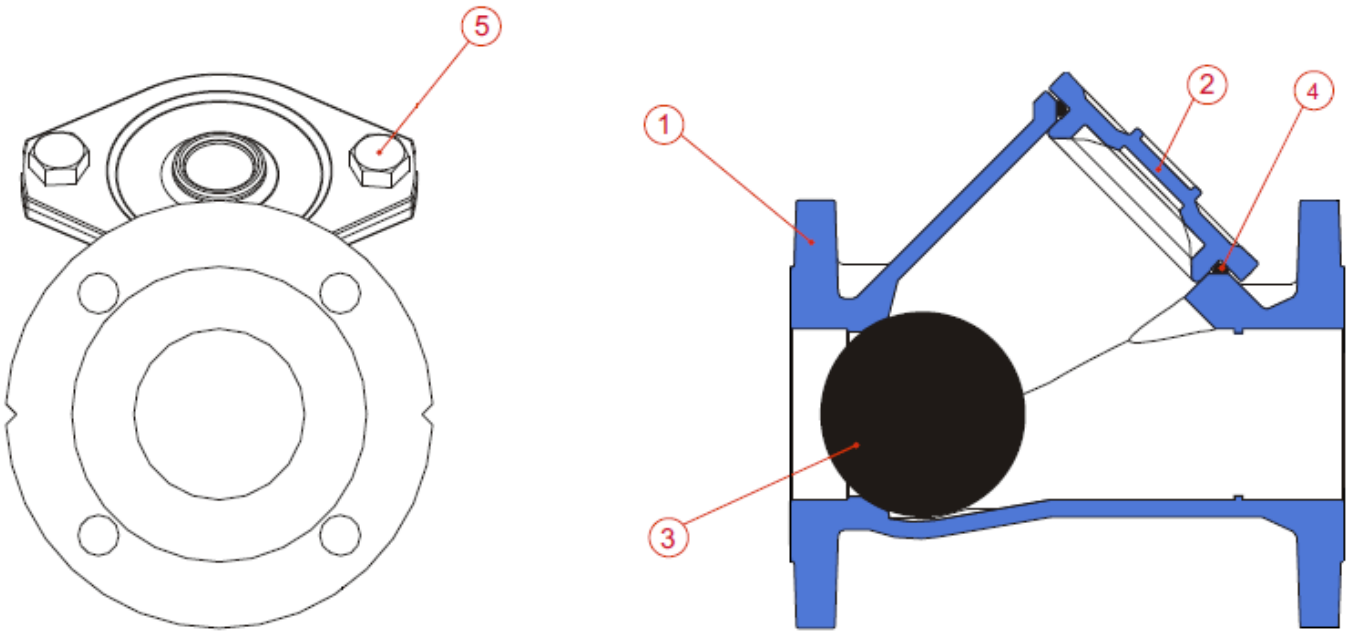

Item	Designation	Materials
1	Body	Ductile iron EN GJS-400-15
2	Bonnet	Ductile iron EN GJS-400-15
3	Ball DN 40 to 200	Aluminium + NBR
	Ball DN 250 to 500	Ductile iron EN GJS-400-15 + NBR
4	Bonnet gasket	NBR
5	Bolting	SS A-2

FLANGED BALL CHECK VALVE PN10

SIZE (in mm) :

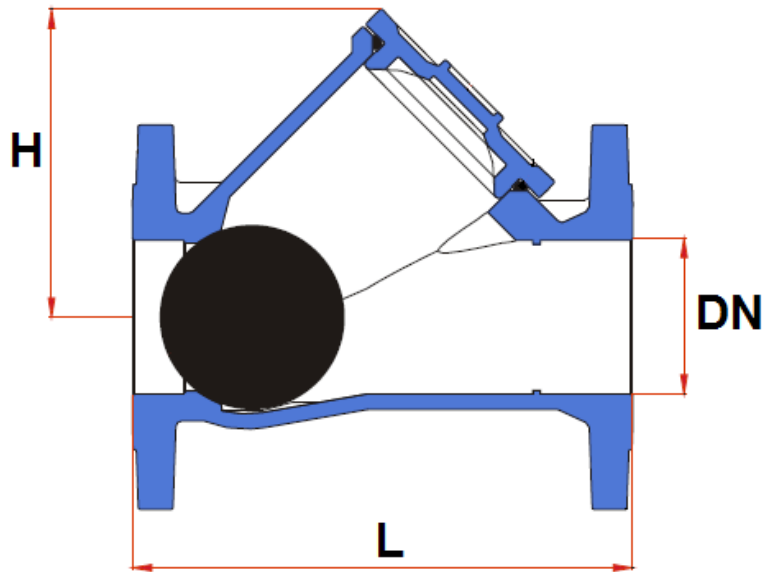
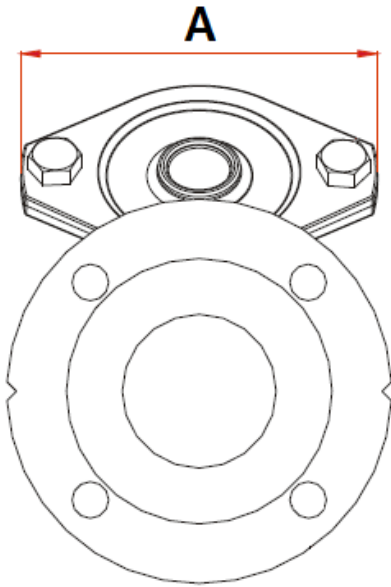

DN	40	50	65	80	100	125	150	200	250	300	350	400	450	500
L	180	200	240	260	300	350	400	500	600	700	800	900	1000	1100
H	90	115	135	160	190	222	268	335	420	495	580	730	760	900
A	120	140	155	185	220	255	290	370	380	445	520	712	712	775
Weight (Kg)	6	8	12	15	21.5	29	45	85	120	180	270	440	500	680

FLANGED BALL CHECK VALVE PN10

FLANGES SIZE (in mm):

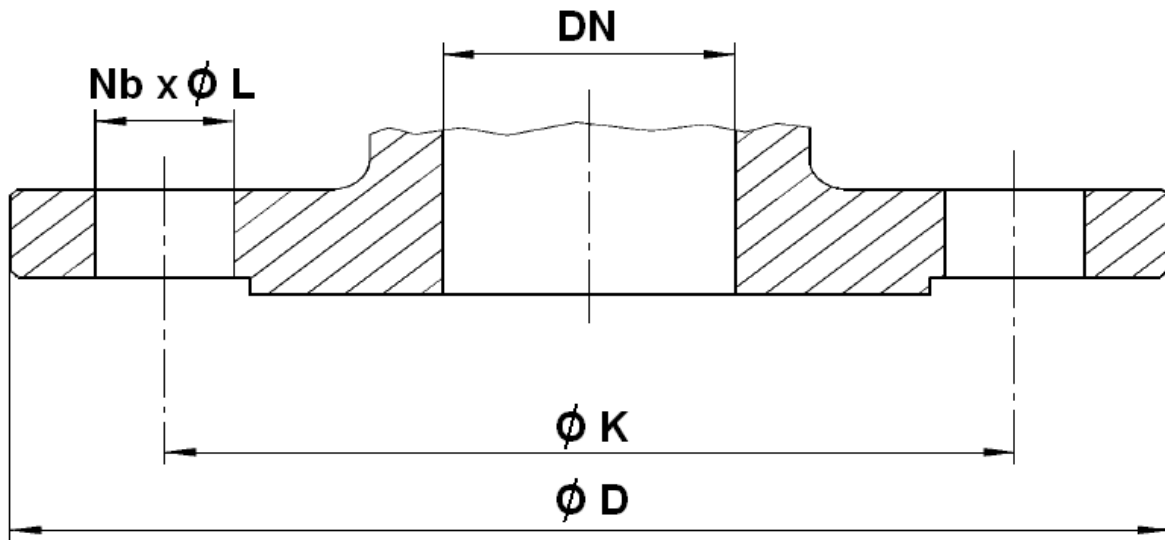

DN	40	50	65	80	100	125	150	200	250	300	350	400	450	500
Ø D	150	165	185	200	226	253	285	342	403	450	505	565	615	670
Ø K	110	125	145	160	180	210	240	295	350	400	460	515	565	620
Nb x Ø L	4 x 19	4 x 19	4 x 1	8 x 19	8 x 19	8 x 19	8 x 23	8 x 23	12 x 23	12 x 23	16 x 23	16 x 27	20 x 27	20 x 27

FLANGED BALL CHECK VALVE PN10

STANDARDS :

- Fabrication according to ISO 9001: 2015 and ISO 14001 : 2015
- DIRECTIVE 2014/68/EU : Products excluded from directive (Article 1, § 2b)
- Tests according to ISO 5208, Rate A
- PN10 Flanged according to EN 1092-2
- Length according to EN 558 series 48 (DIN 3202 F6)
- According to water pumping stations NF EN 12050-4

INSTALLATION POSITIONS :

Vertical position (Ascendant fluid)

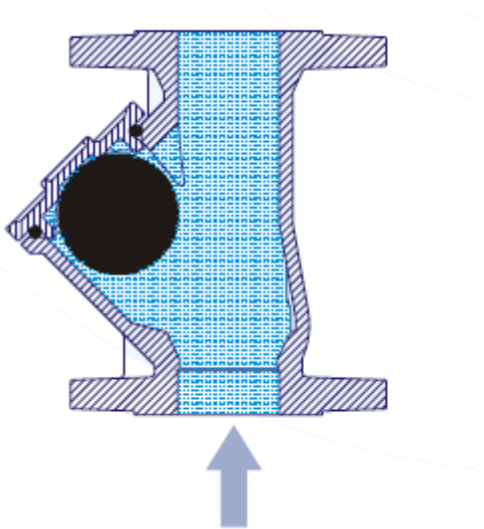

Horizontal position

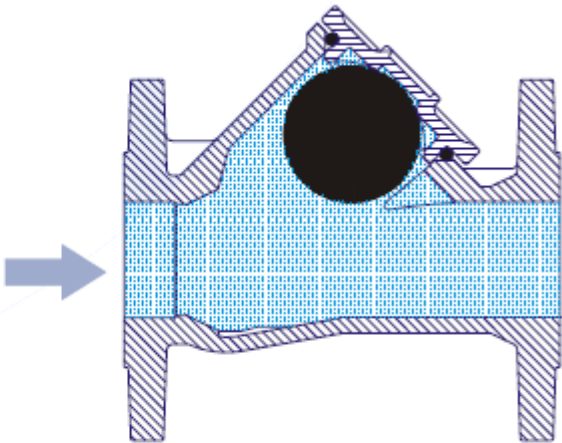

ADVICE : Our opinion and our advice are not guaranteed and Lauridsen group shall not be liable for the consequences of damages. The customer must check the right choice of the products with the real service conditions.

FLANGED BALL CHECK VALVE PN10

INSTALLATION INSTRUCTIONS

GENERAL GUIDELINES :

- Ensure that the check valves to be used are appropriate for the conditions of the installation (type of fluid, pressure and temperature).
- Be sure to have enough valves to be able to isolate the sections of piping as well as the appropriate equipment for maintenance and repair.
- Ensure that the valves to be installed are of correct strength to be able to support the capacity of their usage.

INSTALLATION INSTRUCTIONS :

- **Before installing the check valves, clean and remove any objects from the pipes** (in particular bits of sealing and metal) which could obstruct and block the valves.
- **Ensure that both connecting pipes either side of the check valve (upstream and downstream) are aligned (if they're not, the valves may not work correctly).**
- **Make sure that the two sections of the pipe (upstream and downstream) match, the check valve unit will not absorb any gaps. Any distortions in the pipes may affect the tightness of the connection, the working of the check valve and can even cause a rupture.** To be sure, place the kit in position to ensure the assembling will work.
- **If sections of piping do not have their final support in place, they should be temporarily fixed. This is to avoid unnecessary strain on the check valve.**
- If there is a direction changing or if there's another material, it's better to take away the check valve so that it is outside the turbulence area (**between 3 and 5 times the ND before and after**).
- After a pump please refer to **FD CEN/TR 13932** to install the check valve :
 - If it is essential to keep priming the pump, a non-return check valve can be fitted to the suction pipe at a distance **L1 (straight length suction) > 10xD1 (diameter suction)**
The check valve is designed to meet the maximum flow rate in service
 - In other cases, the non-return check valve is mounted on the discharge pipe at a distance of **L2 (straight length at discharge) > 3xD2 (diameter at discharge)**