

2 PIECES SPLIT BODY BALL VALVE FLANGED CLASS 300 PN50 ICP

2 pieces stainless steel split body ball valve ICP with full bore for Chemical industries, petrochemical industries, hydraulic installation, heating, water distribution, compressed air.

Ball valve with firesafe certificate ISO 10497 to reduce risks in case of fire.

Fugitive emission according to EN 15848-1 :2006 for an excellent tightness on the stem and to prevent external leakage.

PTFE seat for a temperature up to +230°C.

Compatible with explosive atmosphere, ATEX Zone 1&21 and Zone 2&22 thanks to the antistatic device.

Handling possible with gearbox or stainless steel handle.

Thanks to the ISO 5211 plate, an actuator can be installed on the valve.



NACE
MR01-75



Certificate
3.1



Size : DN15 to DN200 (NPS 1/2" to NPS 8")

Connection : Flanged Class 300 (PN50) RF

Min Temperature : -50°C

Max Temperature : +230°C

Max Pressure : 50 bars

Specifications : Antistatic device, ATEX

ISO 5211 mounting pad

Anti blow-out stem, full bore

Fugitive Emissions EN 15848-1 :2006

Fire Safe ISO 10497 :2004

Materials : Stainless Steel ASTM A351 CF8M

2 PIECES SPLIT BODY BALL VALVE FLANGED CLASS 300 PN50 ICP

SPECIFICATIONS :

- Full bore
- Anti blow-out stem
- PTFE seat
- Locking device
- ISO 5211 mounting pad
- 2 pieces type (Split body)
- Class 300 PN50 RF flanges
- Antistatic device
- Fire safe ISO 10497 : 2004
- Fugitive emissions EN 15848-1 : 2006
- Graphite packing + FKM O ring on stem
- With exhaust hole in the ball (located in the top of the ball to avoid overpressure in it)
- Blue painting colour RAL 5009 or Black painting colour RAL 9004, 5-15 microns thickness

USE :

- Chemical industries, petrochemical industries, hydraulic installation, heating, water distribution, compressed air
- Min and max Temperature Ts : -50°C to + 230°C
- Max Pressure Ps : 50 bars
- Vacuum 10⁻² torr
- Compressed air (ambient temperature) : 8 bars maximum
- Steam : 12 bars maximum

PRESSURE / TEMPERATURE GRAPH (STEAM EXCLUDED) :

PRESSURE

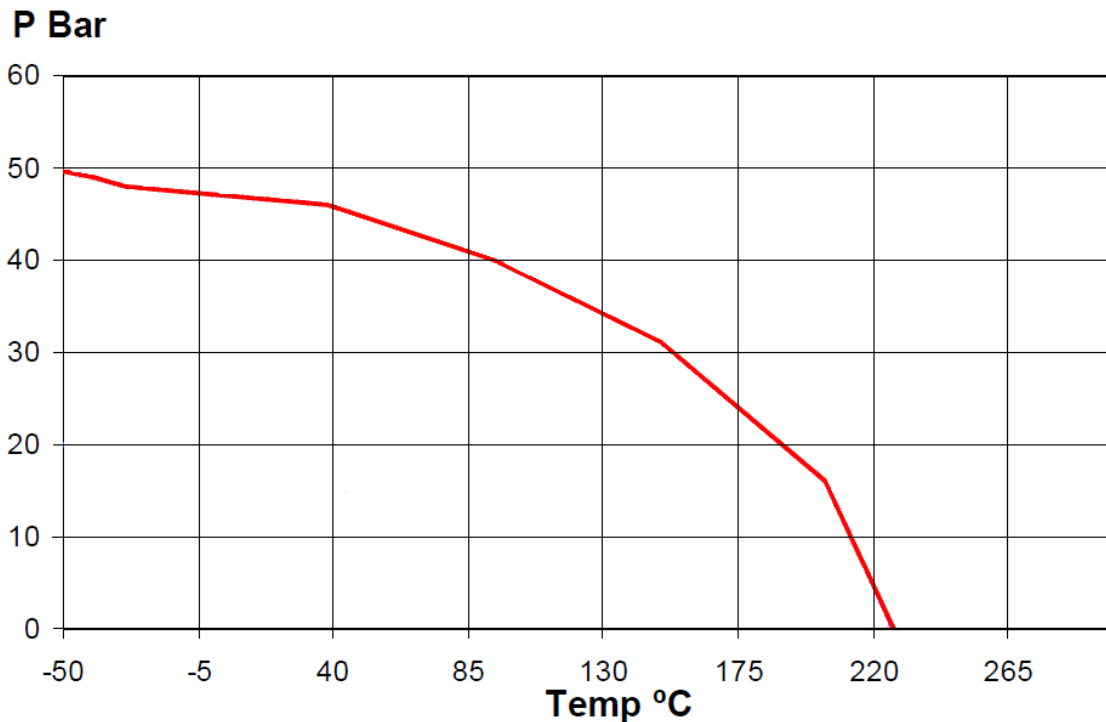

2 PIECES SPLIT BODY BALL VALVE FLANGED CLASS 300 PN50 ICP

FLOW COEFFICIENT Kvs (in m³ / h) :

DN (mm)	15	20	25	40	50	80	100	150	200
NPS (")	1/2"	3/4"	1"	1"1/2	2"	3"	4"	6"	8"
Kvs (m ³ / h)	20	40	75	170	270	1000	1650	4200	9000

TORQUE VALUE (in Nm without safety coefficient) :

DN (mm)	15	20	25	40	50	80	100	150	200
NPS (")	1/2"	3/4"	1"	1"1/2	2"	3"	4"	6"	8"
Torque (Nm)	10	13	17	30	49	135	170	308	780

RANGE :

- Stainless steel ball valve **Ref. 769** DN 15 to DN 200 (NPS 1/2" to 8")
- Possible with gearbox **Ref. 9830221 and 9830266-267** from DN 100 to 200 (NPS 4" to 8")
- Stainless steel handle ASTM A351 CF8M **Ref. 9812090-9812097** from DN 15 to DN 200 (NPS 1/2" to 8")

ENDS:

- Class 300 (PN50) R.F. Flanges

2 PIECES SPLIT BODY BALL VALVE FLANGED CLASS 300 PN50 ICP

VALVE MATERIALS :

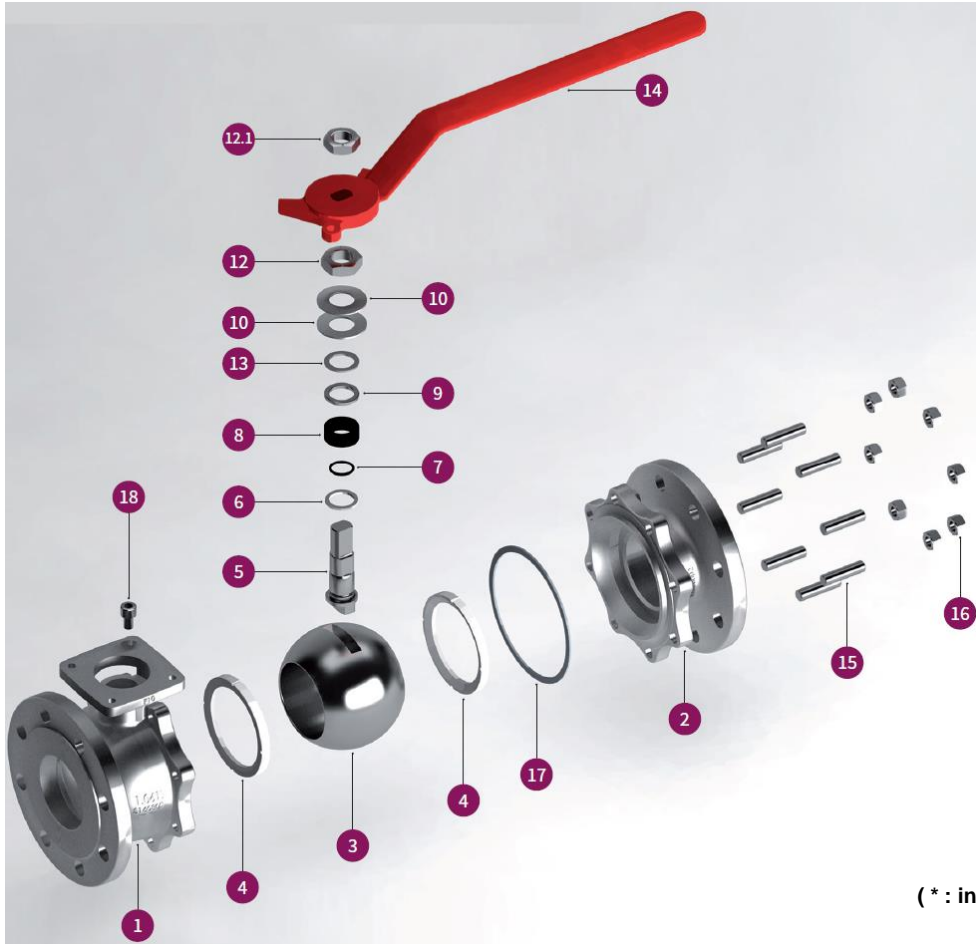

(* : included in gaskets kit)

Item	Designation	Materials
1	Body	ASTM A351 CF8M
2	Ends	
3	Ball	
4*	Seat	PTFE
5	Stem	ASTM A479 type 316
6*	Stem thrust seal	PTFE filled with 25% glass
7*	Stem O ring	FKM
8*	Gland Packing	Graphite
9	Gland	AISI 303
10	Elastic ring	Inconel 718
12	Gland nut	AISI 303
12.1	Handle nut	AISI 303
13	Antifriction washer	PTFE filled with 25% glass
14	Handle	Nodular iron
15	Stud	A 193 Gr. B8M
16	Nut	A 194 Gr. 8M
17*	Spiralwound gasket	SS 316L + PTFE + Graphite
18	Bolt	A2

2 PIECES SPLIT BODY BALL VALVE FLANGED CLASS 300 PN50 ICP

GEARBOX MATERIALS :

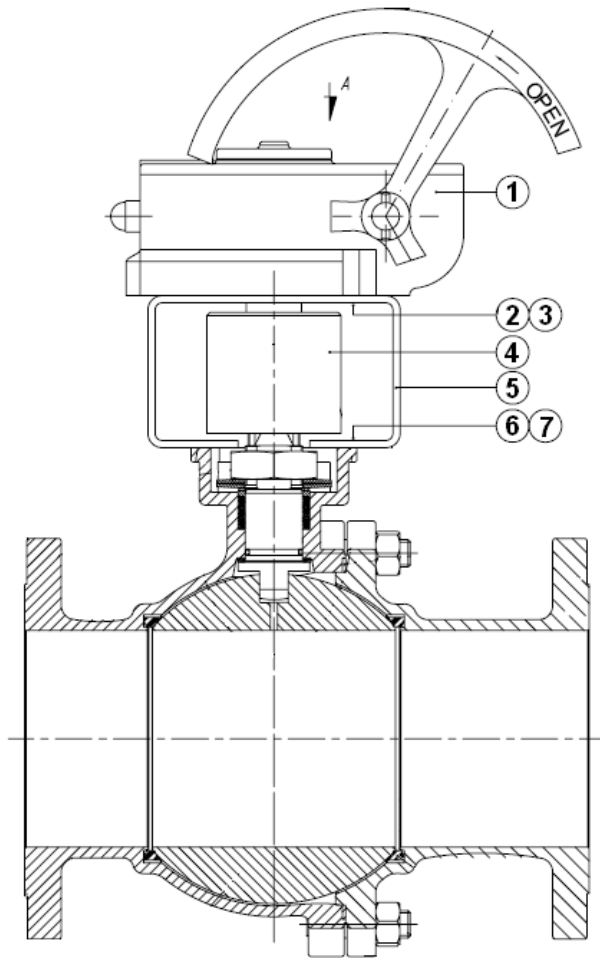

Item	Designation	Materials
1	Gearbox	Painted steel
2	Screw	DIN 912 A2
3	Washer	DIN 912 A2
4	Coupling	Stainless steel
5	Mounting bracket	Stainless steel
6	Screw	DIN 912 A2
7	Washer	DIN 912 A2

2 PIECES SPLIT BODY BALL VALVE FLANGED CLASS 300 PN50 ICP

VALVE SIZE (in mm) :

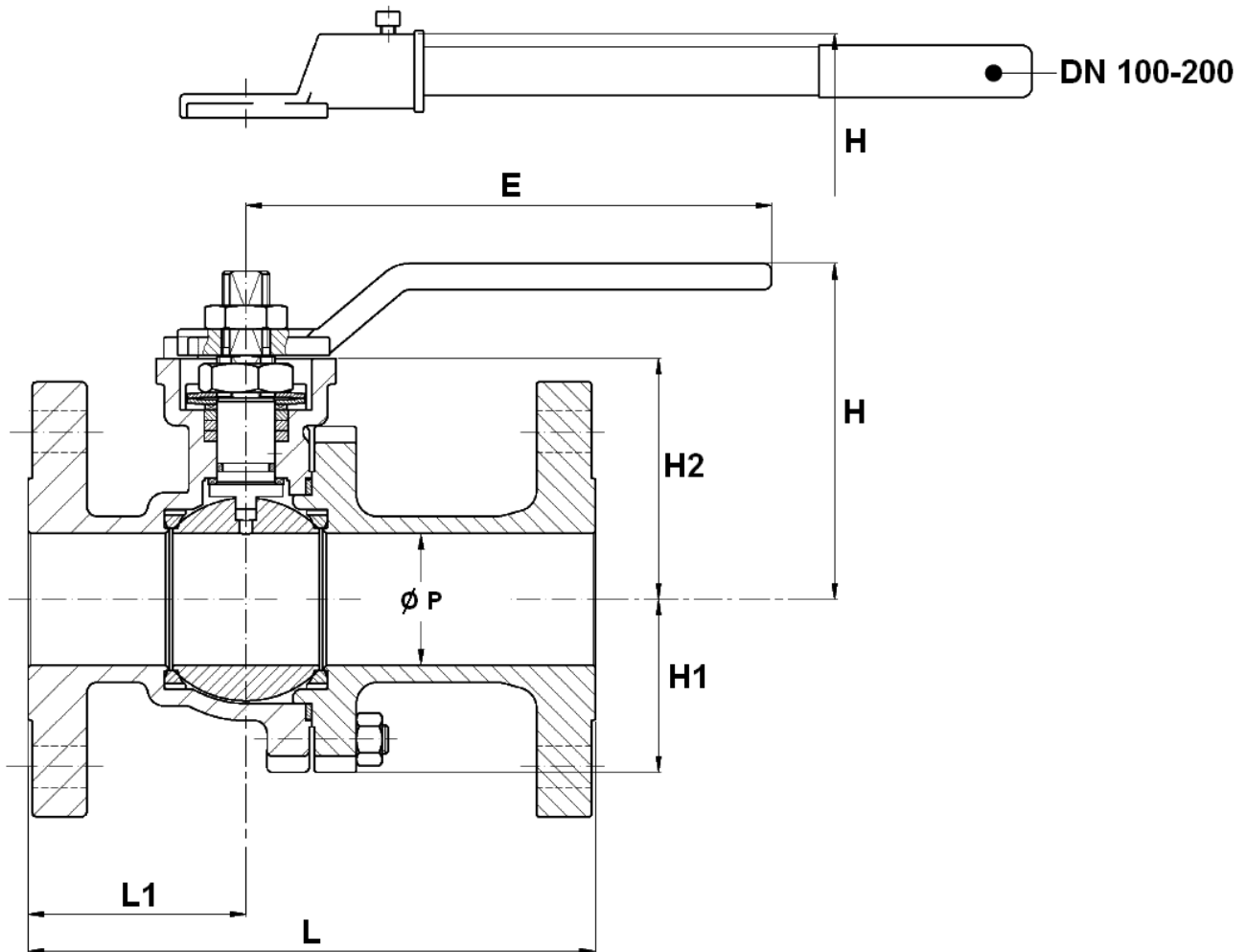

DN (mm)	15	20	25	40	50	80	100	150	200
NPS (")	1/2"	3/4"	1"	1 1/2"	2"	3"	4"	6"	8"
Ø P	15	20	25	40	50	78	100	151	203
L	140	152	165	190	216	283	305	403	502
L1	60	65	70	80	83	118	133	160	239
E	170	170	170	215	215	430	466	680	845
H	68	70	86	122.5	127.5	190	192.5	259	319
H1	31	33	39	48	63	87	108	152	202
H2	41	43	58.5	86.5	91.5	118.5	144	203	250
Weight (Kg)	2.5	3.7	4.7	9.4	12.2	25	39.5	88.1	160.5
Ref.	769015	769020	769025	769040	769050	769080	769100	769150	769200

2 PIECES SPLIT BODY BALL VALVE FLANGED CLASS 300 PN50 ICP

STEM AND ISO PLATE SIZE (in mm) :

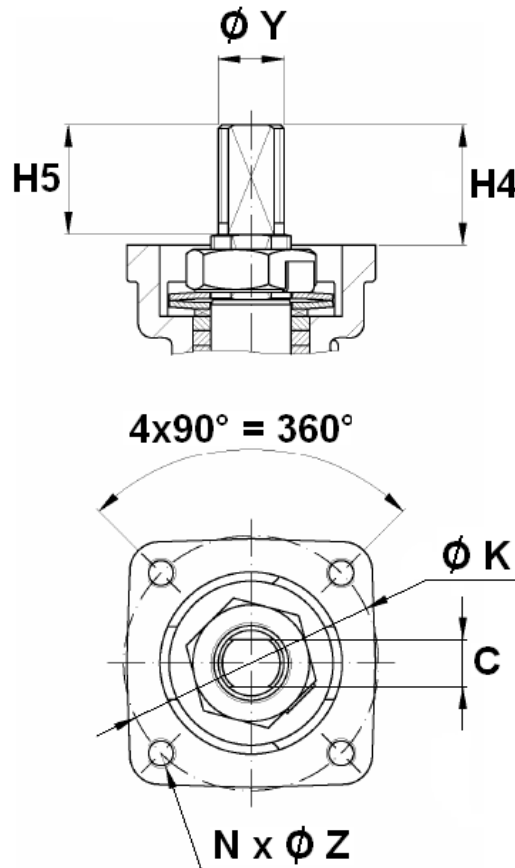

DN (mm)	15	20	25	40	50	80	100	150	200
NPS (")	1/2"	3/4"	1"	1 1/2"	2"	3"	4"	6"	8"
H4	18	18	22	33	33	34	45	56	69
H5	11	11	21	32	32	33	43.5	54.5	67
C	7	7	8	12	12	15	19	24	32
$\varnothing Y$	M10	M10	M12	M18	M18	M22	M28	M36	M48
$\varnothing K$	50	50	50	70	70	102	102	125	140
ISO	F05	F05	F05	F07	F07	F10	F10	F12	F14
N x $\varnothing Z$	4 x M6	4 x M6	4 x M6	4 x M8	4 x M8	4 x M10	4 x M10	4 x M12	4 x M16

2 PIECES SPLIT BODY BALL VALVE FLANGED CLASS 300 PN50 ICP

FLANGES SIZE (in mm) :

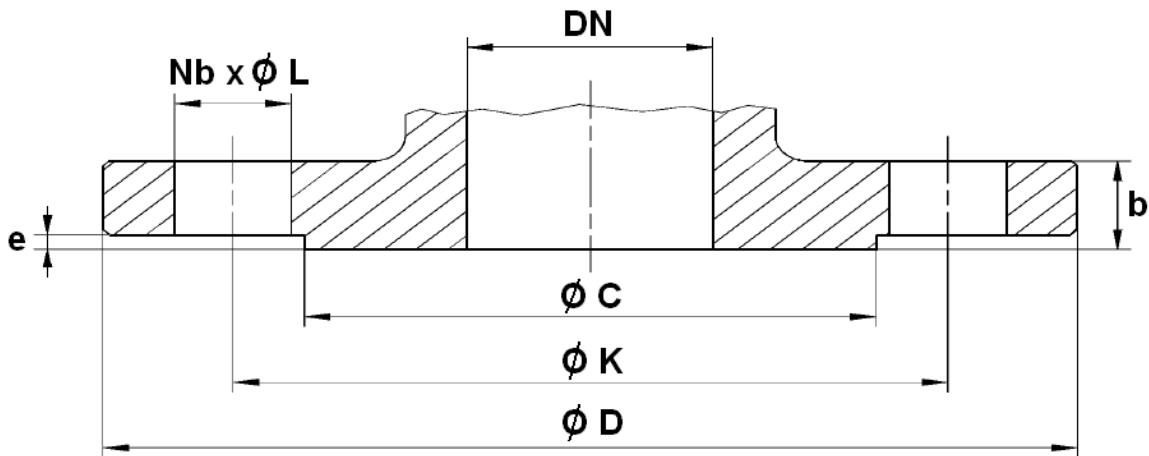

DN (mm)	15	20	25	40	50	80	100	150	200
NPS (")	1/2"	3/4"	1"	1"1/2	2"	3"	4"	6"	8"
Ø C	35	43	51	73	92	127	157	216	270
Ø D	95	117.5	124	155.5	165	210	254	318	381
Ø K	66.55	82.55	88.9	114.3	127	168.1	200.15	269.75	330.2
Nb x Ø L	4 x 15.74	4 x 19	4 x 19	4 x 22.2	8 x 19	8 x 22.2	8 x 22.2	12 x 22.2	12 x 25.4
b	14.3	15.8	17.6	20.6	22.4	28.5	31.8	36.6	41.2
e	1.6	1.6	1.6	1.6	1.6	1.6	1.6	1.6	1.6

2 PIECES SPLIT BODY BALL VALVE FLANGED CLASS 300 PN50 ICP

GEARBOX SIZE (in mm) :

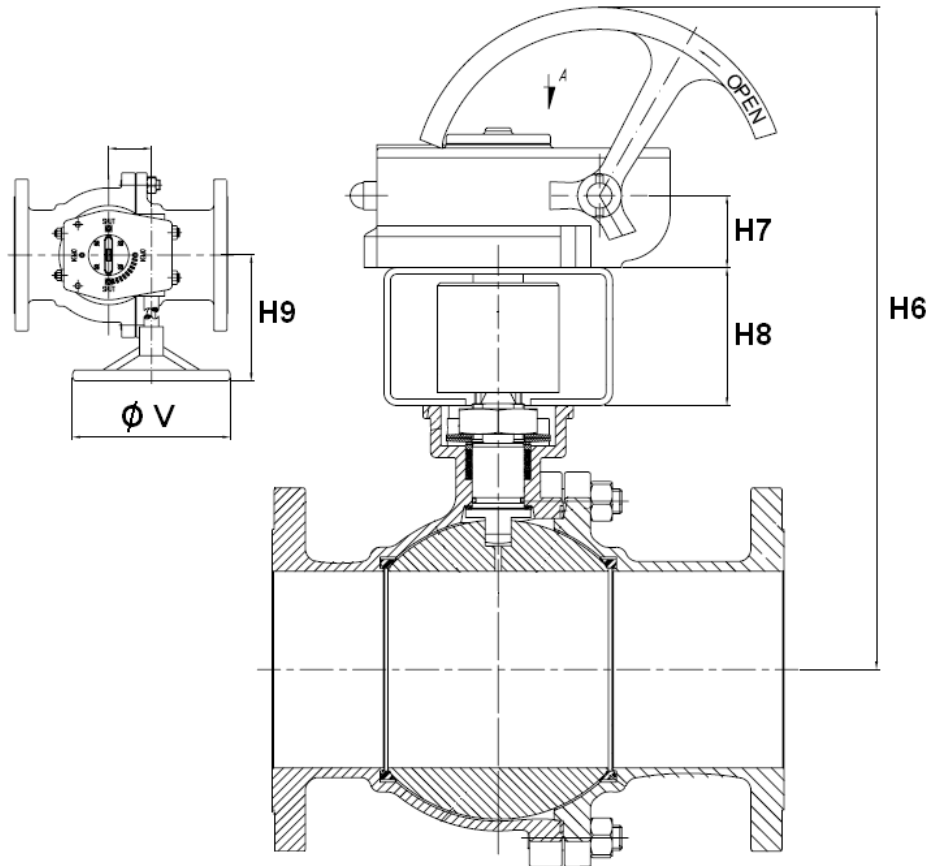

DN (mm)	100	150	200
NPS (")	4"	6"	8"
H6	521.5	596.5	643.5
H7	55	55	55
H8	90	106	106
H9	229	229	229
Ø V	465	465	465
Ref. gearbox alone	9830221	9830266	9830267
Weight gearbox alone (in Kg)	17.8	19.5	19.7
Weight gearbox+valve (in Kg)	47.1	84	142.9

2 PIECES SPLIT BODY BALL VALVE FLANGED CLASS 300 PN50 ICP

STAINLESS STEEL HANDLE SIZE (in mm) :

DN 15 - 80

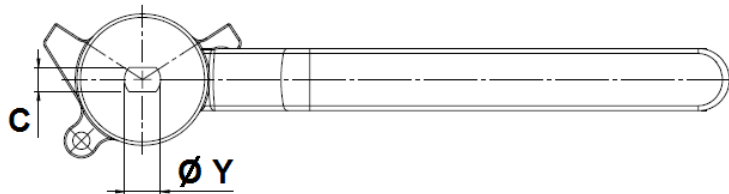
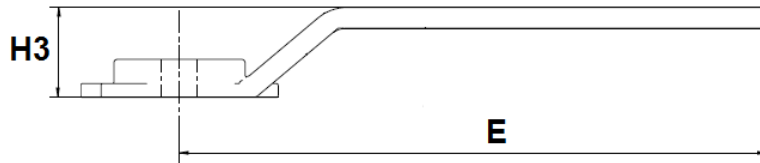

DN 100 - 200

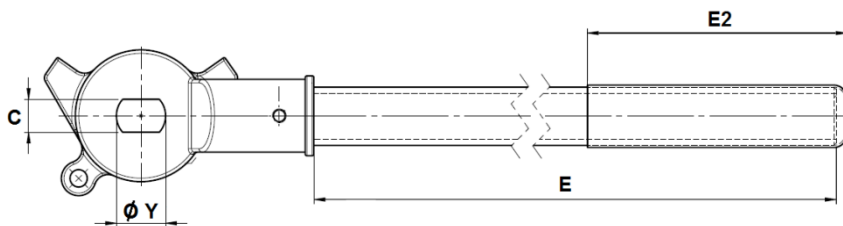
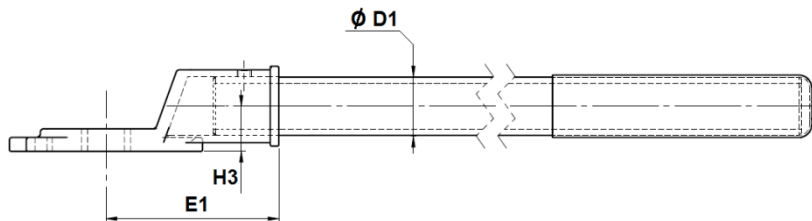

DN	15-20	25-32	40-50	65	80	100	125-150	200
NPS (")	1/2"-3/4"	1"-1 1/4"	1 1/2"-2"	2 1/2"	3"	4"	5"-6"	8"
E	170	170	215	335	430	375	578	730
E1	-	-	-	-	-	100	115	140
E2	-	-	-	-	-	120	200	200
H3	26	26	35	35	71	26	30	36
Ø D1	-	-	-	-	-	26.8	33	42
C	7	8	12	15	15	19	24	32
Ø Y	10.5	12.5	18.5	22.5	22.5	28.5	36.5	48.5
Ref.	9812090	9812091	9812092	9812093	9812094	9812095	9812096	9812097

2 PIECES SPLIT BODY BALL VALVE FLANGED CLASS 300 PN50 ICP

STANDARDS :

- Fabrication according to ISO 9001:2015
- DIRECTIVE 2014/68/EU : CE N° 0035
Risk Category III module H
- Certificate 3.1 on request
- Valve designing according to EN 1983 – ISO 17292 and ASME B16.34
- Materials according to NACE MR 01-75
- Pressure Tests according to EN 12266-1, Rate A and API 598
- Marking according to EN 19
- Fire safe according to ISO 10497 : 2004
- Fugitive Emissions according to EN 15848-1 : 2006
- Class 300 (PN50) Flanges R.F. according to ASME B16.5
- ISO 5211 mounting pad and stem size according to EN 15081
- Length according to ASME B16.10 (EN 558 series 4 up to DN150)
- ATEX Group II Category 2 G/2Dc Zone 1 & 21 Zone 2 & 22 (optional marking) according to directive 2014/34/EU

ADVICE : Our opinion and our advice are not guaranteed and Lauridsen group shall not be liable for the consequences of damages. The customer must check the right choice of the products with the real service conditions.



2 PIECES SPLIT BODY BALL VALVE FLANGED CLASS 300 PN50 ICP

INSTALLATION INSTRUCTIONS

GENERAL GUIDELINES :

- Ensure that the valves to be used are appropriate for the conditions of the installation (type of fluid, pressure and temperature).
- Be sure to have enough valves to be able to isolate the sections of piping as well as the appropriate equipment for maintenance and repair.
- Ensure that the valves to be installed are of correct strength to be able to support the capacity of their usage.
- **Installation of all circuits should ensure that their function can be automatically tested on a regular basis (at least two times a year).**

INSTALLATION INSTRUCTIONS :

- **Before installing the valves, clean and remove any objects from the pipes** (in particular bits of sealing and metal) which could obstruct and block the valves.
- **Ensure that both connecting pipes either side of the valve (upstream and downstream) are aligned (if they're not, the valves may not work correctly).**
- **Make sure that the two sections of the pipe (upstream and downstream) match, the valve unit will not absorb any gaps. Any distortions in the pipes may affect the tightness of the connection, the working of the valve and can even cause a rupture.** To be sure, place the kit in position to ensure the assembling will work.
- **If sections of piping do not have their final support in place, they should be temporarily fixed. This is to avoid unnecessary strain on the valve.**
- Tighten the bolts in cross.
- It's recommended to operate the valve (open and close) 1 to 2 times per year