

CAST IRON DUAL PLATE CHECK VALVE STAINLESS STEEL DISC EPDM SEAT

Cast iron dual plate check valve for heating and water distribution.

Cast iron EN GJL-250 body coated with anti-corrosion epoxy painting, stainless steel disc and vulcanized EPDM seat.

Wafer type with short length and with a hoisting eye from DN200 to 600 for easy installation.

Certificate**3.1****Size :** DN 50 to 600**Ends :** Between flanges PN10/16
Class 150 (PN20) from DN100 to 600**Min Temperature :** -10°C**Max Temperature :** +110°C**Max Pressure :** 16 Bars up to DN300**Specifications :** EPDM vulcanized seat

Horizontal or vertical position with ascendant fluid

Wafer type

Hoisting eye from DN200 to 600

Weak headloss

Materials : Cast iron EN GJL-250 body

CAST IRON DUAL PLATE CHECK VALVE STAINLESS STEEL DISC EPDM SEAT

SPECIFICATIONS :

- Vulcanized gasket
- Hoisting eye from DN200 to 600
- Short length
- Anti-corrosion stainless steel spring
- PTFE bushing
- Weak head loss
- Vertical position with ascendant fluid or horizontal position (respect the flow direction indicated by the arrow)
- Between flanges PN10/16, and Class 150 PN20 from DN100 to 600
- Anti-corrosion epoxy painting RAL003 50-100 microns thickness for body
- Minimum backpressure for tightness : 2 bars

USE :

- Heating, water distribution
- Min and max Temperature Ts : - 10°C to + 110°C
- Max Pressure Ps : 16 bars up to DN300 included and 10 bars over
- **Do not use with pulsatory speed**

HEAD LOSS GRAPH :

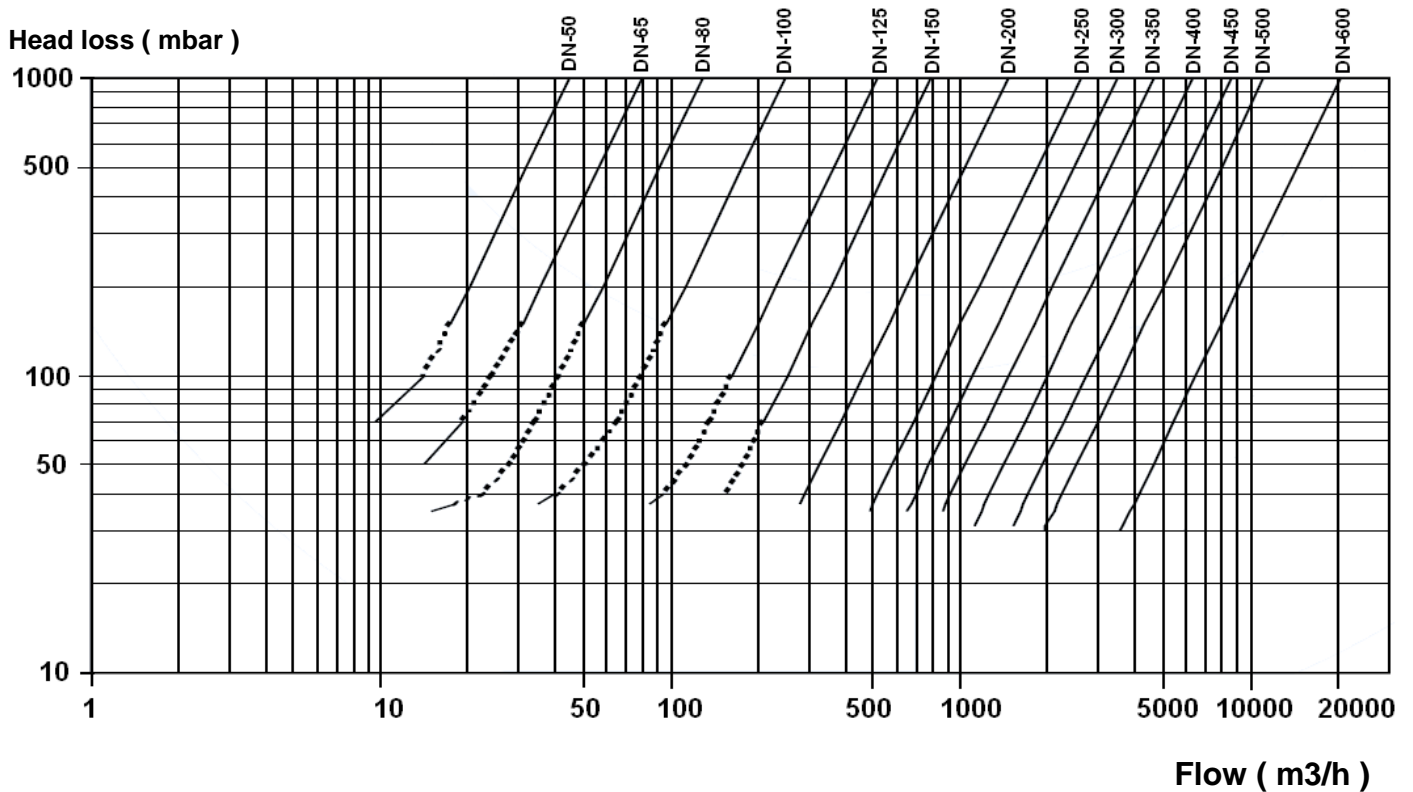

OPENING PRESSURE (in mbar) :

DN	50	65	80	100	125	150	200	250	300
Horizontal position	230	94	190	280	160	79	41	38	31
Vertical position ascend. fluid	260	114	230	320	180	95	57	58	56

CAST IRON DUAL PLATE CHECK VALVE STAINLESS STEEL DISC EPDM SEAT

RANGE :

- Dual plate check valve with cast iron body and stainless steel disc between flanges PN10/16 Ref. 371 From DN50 to DN 600
- Between flanges Class 150 PN20 possible from DN100 to 600

MATERIALS DN50-80 :

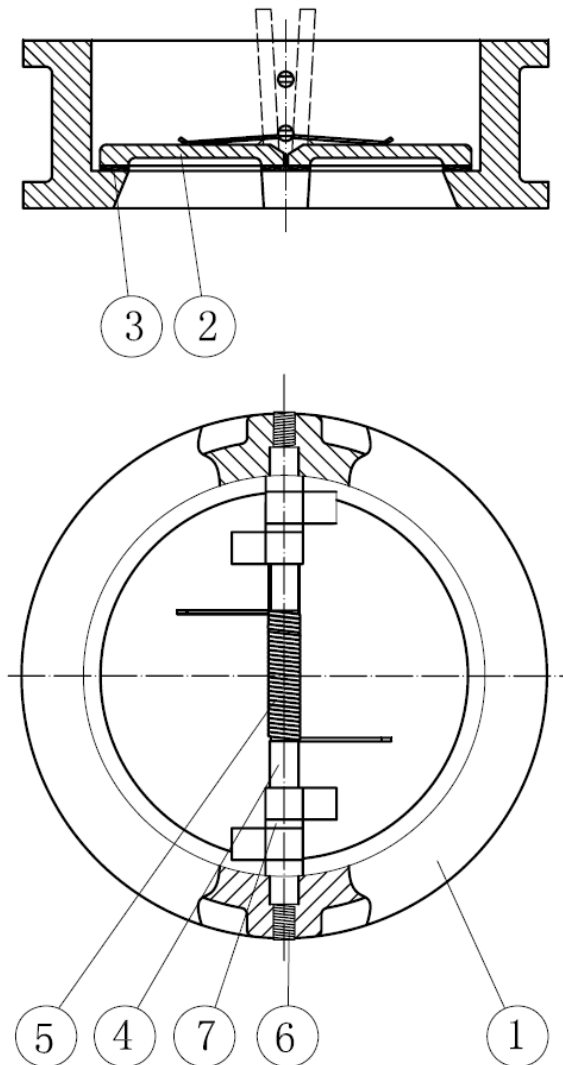

Item	Designation	Materials
1	Body	Cast iron EN-GJL 250
2	Disc	ASTM A351 CF8M
3	Seat	EPDM
4	Shaft	AISI 316
5	Spring	
6	Screw	Galvanized carbon steel
7	Spacer	PTFE

CAST IRON DUAL PLATE CHECK VALVE STAINLESS STEEL DISC EPDM SEAT

MATERIALS DN100 - 600 :

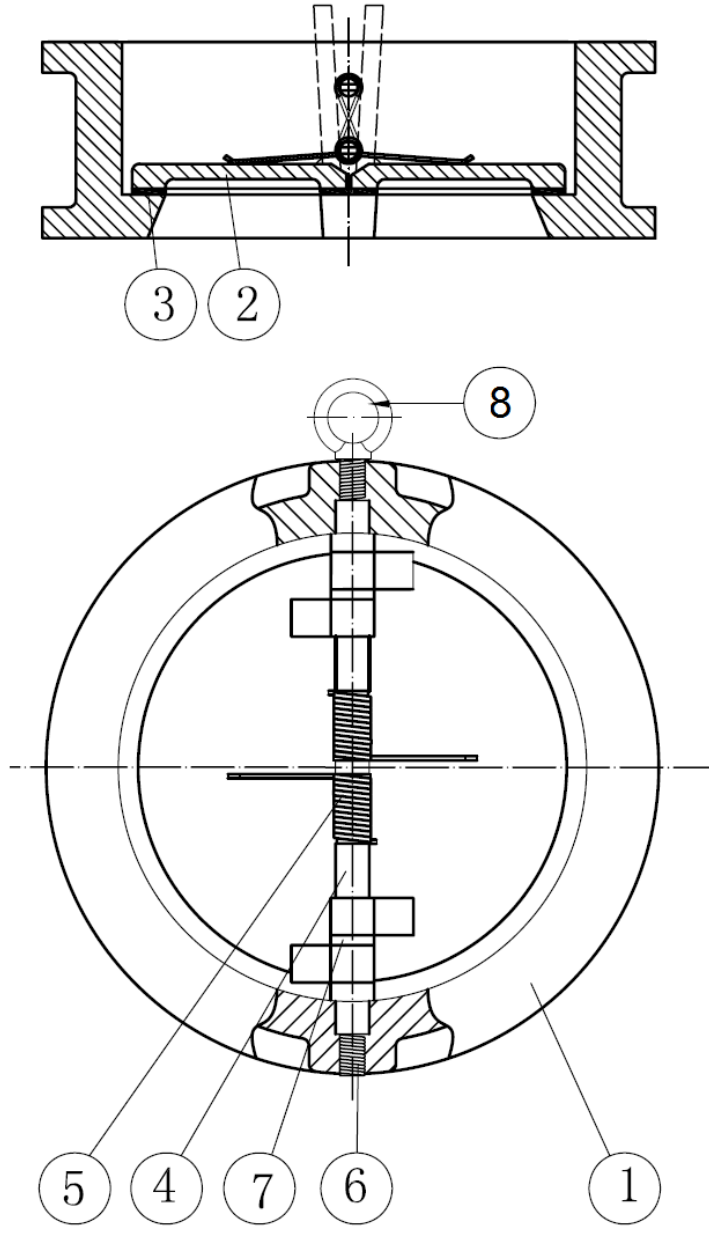

Item	Designation	Materials
1	Body	Cast iron EN-GJL 250
2	Disc	ASTM A351 CF8M
3	Seat	EPDM
4	Shaft	AISI 316
5	Spring	
6	Screw	Galvanized carbon steel
7	Spacer	PTFE
8	Hoisting eye (from DN200 to 600)	AISI 304

CAST IRON DUAL PLATE CHECK VALVE STAINLESS STEEL DISC EPDM SEAT

SIZE (in mm) :

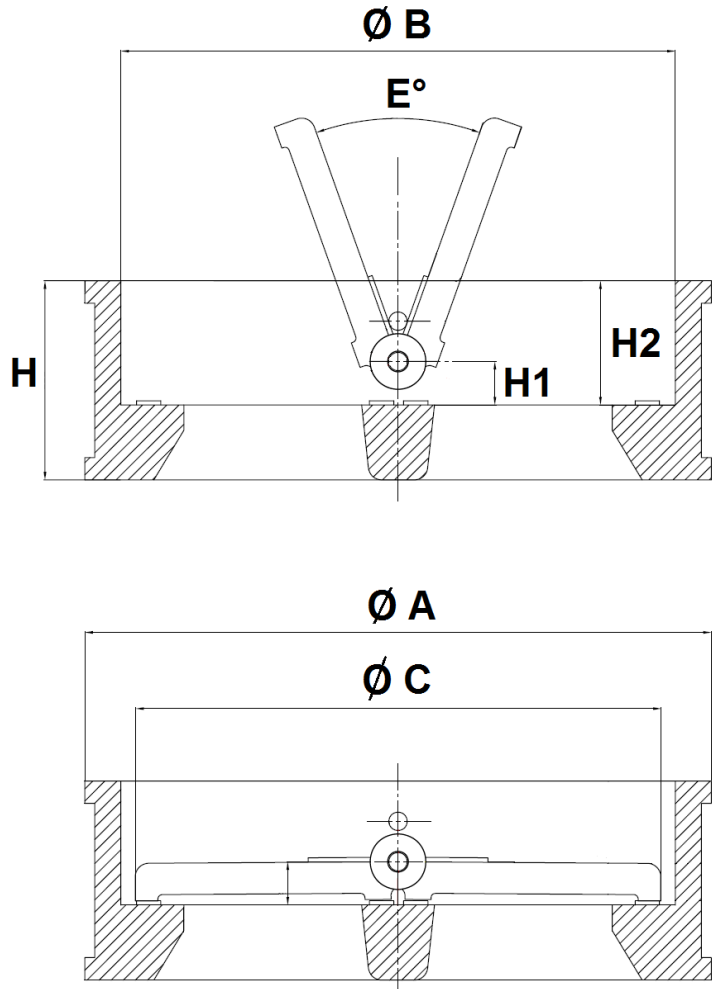

DN	50	65	80	100	125	150	200	250	300	350	400	450	500	600
H	54	54	57	64	70	76	95	108	144	184	191	203	213	222
H1	14.4	16.9	19.9	21	22.3	22.5	28	34	37	35	37.5	42.2	39.5	48.5
H2	43	43	45	47	51	54	69	71	100	120	123	122.6	132	138.5
Ø A	109	129	144	164	194	220	275	330	380	440	491	541	596	697
Ø B	70.5	83.5	91.5	115.5	142.5	169.5	220.5	275.5	325.5	356	406	467	514	616
Ø C	60.5	75.8	80.5	104.5	130.3	155.9	201.2	257.2	303.3	345.9	388.6	431.2	486.8	607.6
E°	0°	0°	0°	0°	0°	0°	0°	0°	0°	20°	20°	20°	25°	25°
Weight (Kg)	1.62	2.3	3.14	4.5	6.7	9.05	16	26.9	38.9	80	106	128	158	225
Ref.	371050	371065	371080	371100	371125	371150	371200	371250	371300	371350	371400	371450	371500	371600

CAST IRON DUAL PLATE CHECK VALVE STAINLESS STEEL DISC EPDM SEAT

STANDARDS :

- Manufacturer certified ISO 9001 : 2015
- DIRECTIVE 2014/68/EU : CE N° 0035
Risk Category III Module H
- Certificate 3.1 on request
- Designing according to API 594
- Pressure tests according to API 598, table 6
- Length according to EN 558 Series 50
- Between flanges according to EN 1092-1 PN10/16

INSTALLATION POSITIONS :

Vertical position (ascendant fluid)

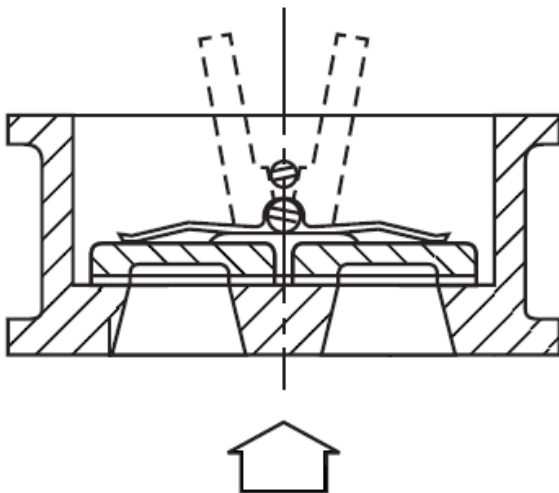

Horizontal position

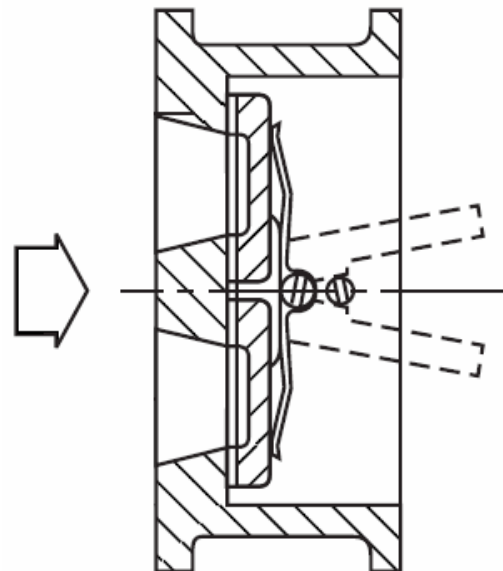

ADVICE : Our opinion and our advice are not guaranteed and Lauridsen group shall not be liable for the consequences of damages. The customer must check the right choice of the products with the real service conditions.