

CAST IRON GLOBE VALVE HIGH TEMPERATURE PN16



ISO 9001 : 2015
BUREAU VERITAS
Certification



PED/2014/68/UE
BUREAU VERITAS
Certification



Certificate 3.1

Size : DN 15 to DN 200
Ends : Flanges R.F. PN16
Min Temperature : -10°C
Max Temperature : + 300°C
Max Pressure : 16 Bars
Specifications : Rising rotating stem and handwheel
Bolted bonnet and gland packing
High temperature

Materials : Cast iron EN GJL-250

CAST IRON GLOBE VALVE HIGH TEMPERATURE PN16

SPECIFICATIONS :

- Respect the flow direction (indicated by the arrow)
- Rising rotating stem and handwheel
- Pressed seat
- Bolted bonnet and gland packing
- Flanges R.F. PN16
- Grey painting RAL 7011-7012, 50-100µ thickness

USE :

- For all common fluids
- Min and max Temperature Ts : - 10°C to + 300°C
- Max Pressure Ps : 16 bars (see graph)
- Keep greased the stem
- Do not use for convector fluid
- Tighten the gland packing in service
- **Steam : 10 bars maximum**

FLOW COEFFICIENT Kvs (M3 / h) :

DN	15	20	25	32	40	50	65	80	100	125	150	200
Kvs (m3/h)	5.9	7.4	13	18	30	41	79	115	181	225	364	690

PRESSURE / TEMPERATURE GRAPH :

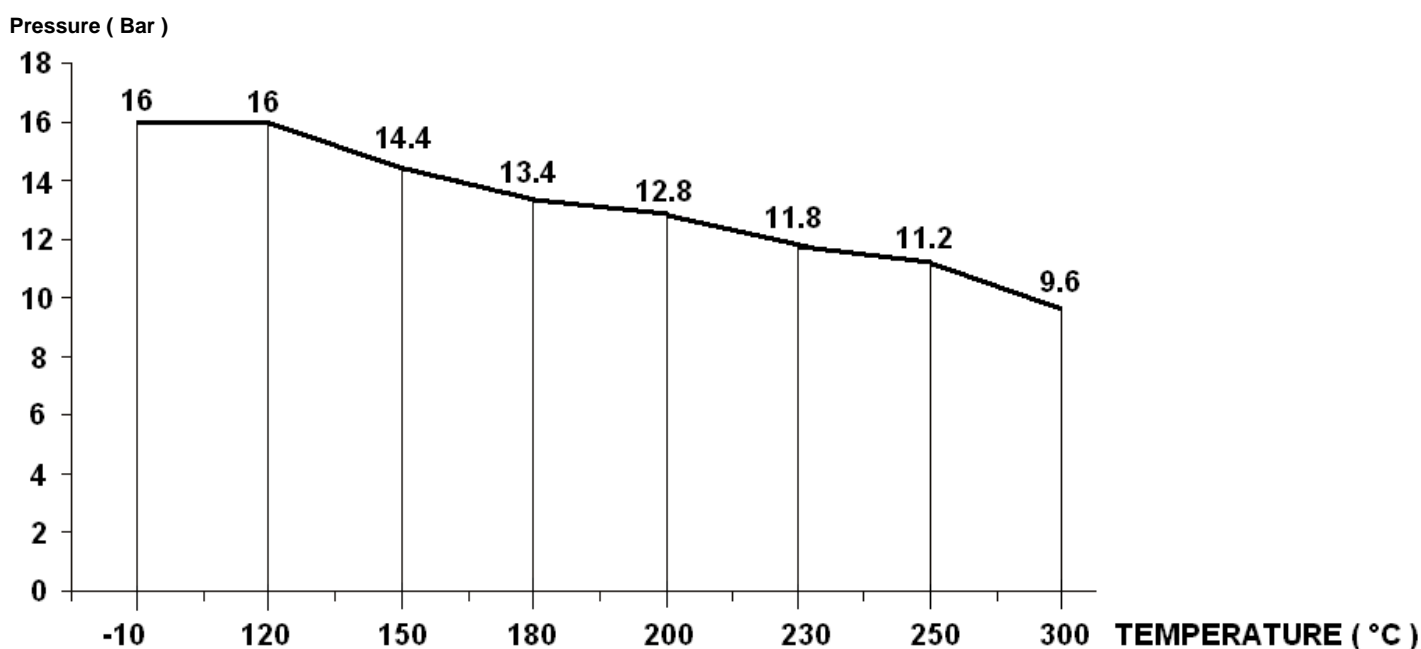

CAST IRON GLOBE VALVE HIGH TEMPERATURE PN16

RANGE :

- Cast iron flanges R.F. PN16 Ref. 479 DN 15 to DN 200

MATERIALS:

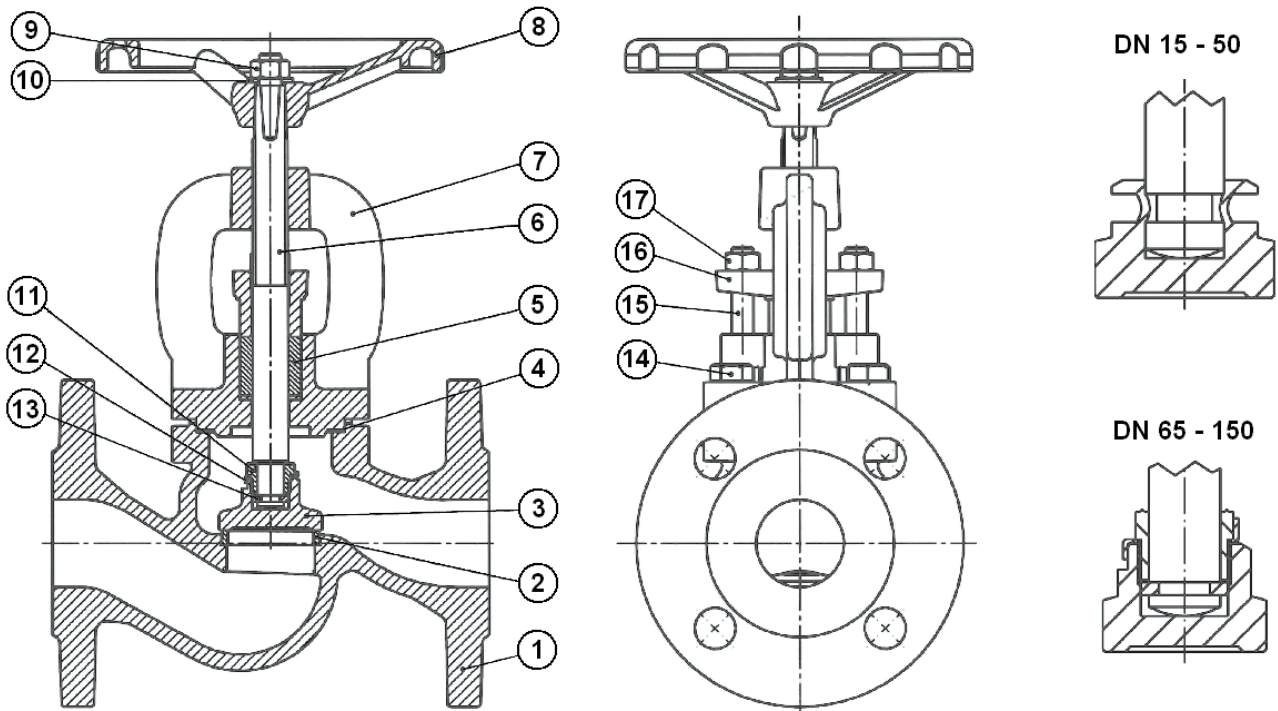

Item	Designation	Materials
1	Body	Cast iron EN GJL-250
2	Seat	SS 410 (1.4006)
3	Disc	SS 420 (1.4021)
4	Bonnet gasket	Graphite + NiCr
5	Gland packing	Graphite
6	Stem	SS 420 (1.4021)
7	Bonnet	Cast iron EN GJL-250
8	Handwheel	Cast iron EN GJS-500-7
9	Handwheel nut	Galvanized steel
10	Washer	Galvanized steel
11*	Disc screw	SS 420 (1.4021)
12*	Disc washer	SS 321 (1.4541)
13*	Ring	SS 420 (1.4021)
14	Hexagon bolt	8.8
15	T bolt	Galvanized steel 5.8
16	Gland	Cast iron EN GJL-250
17	Gland nut	Galvanized steel

* : only for DN 65 to 200

CAST IRON GLOBE VALVE HIGH TEMPERATURE PN16

SIZE (in mm) :

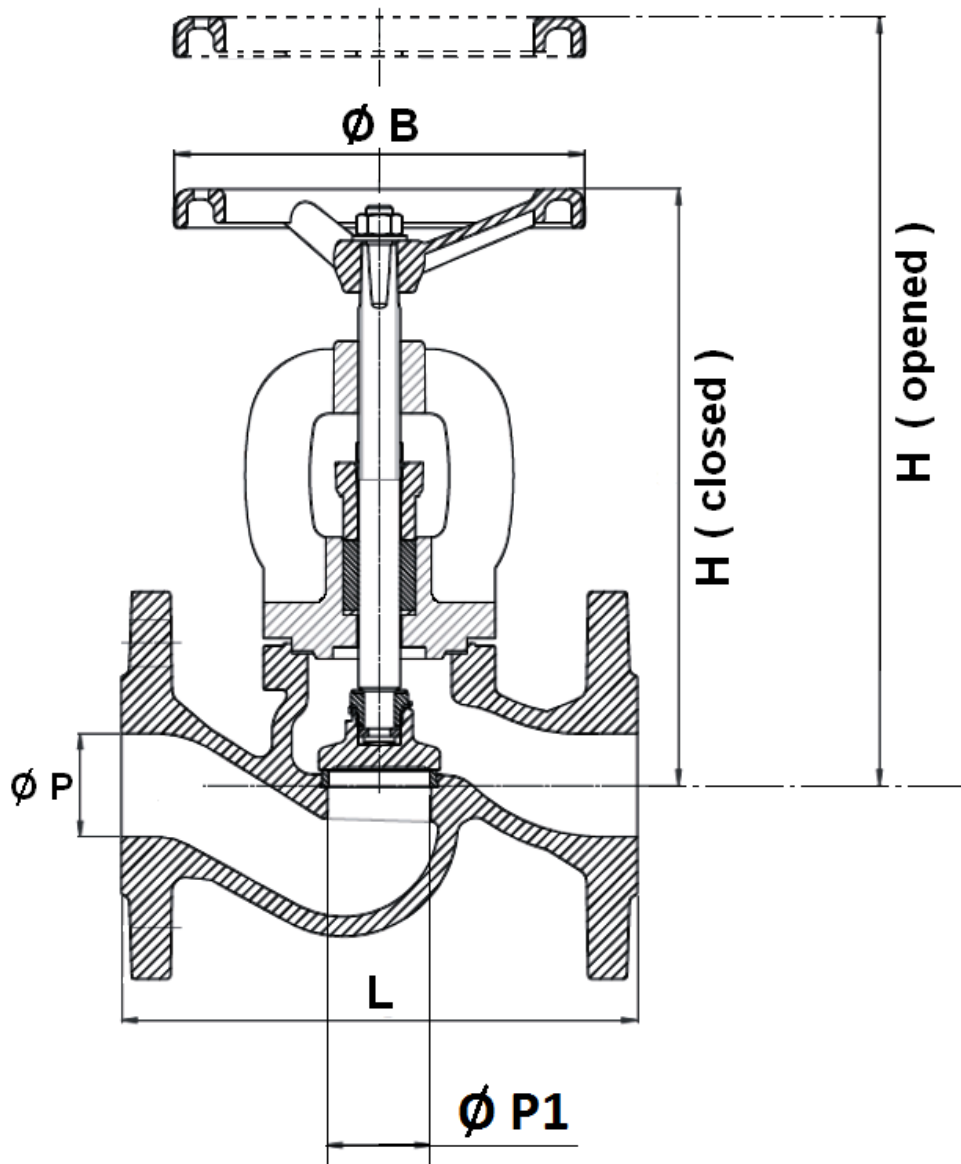

Ref.	DN	15	20	25	32	40	50	65	80	100	125	150	200
479	Ø P	15	20	25	32	40	50	65	80	100	125	150	200
	Ø P1	17	20	25	32	39	50	65	80	100	125	150	200
	L	130	150	160	180	200	230	290	310	350	400	480	600
	H (opened)	193	194	203	212	263	273	305	344	378	420	483	606
	H (closed)	178	180	188	191	235	238	270	297	344	375	429	525
	Ø B	100	100	120	120	160	160	180	200	250	250	320	360
	Weight (Kg)	3.3	3.9	5	6.6	9.5	12	17.3	22.7	35.8	52.8	72.5	126

CAST IRON GLOBE VALVE HIGH TEMPERATURE PN16

FLANGES SIZE (in mm):

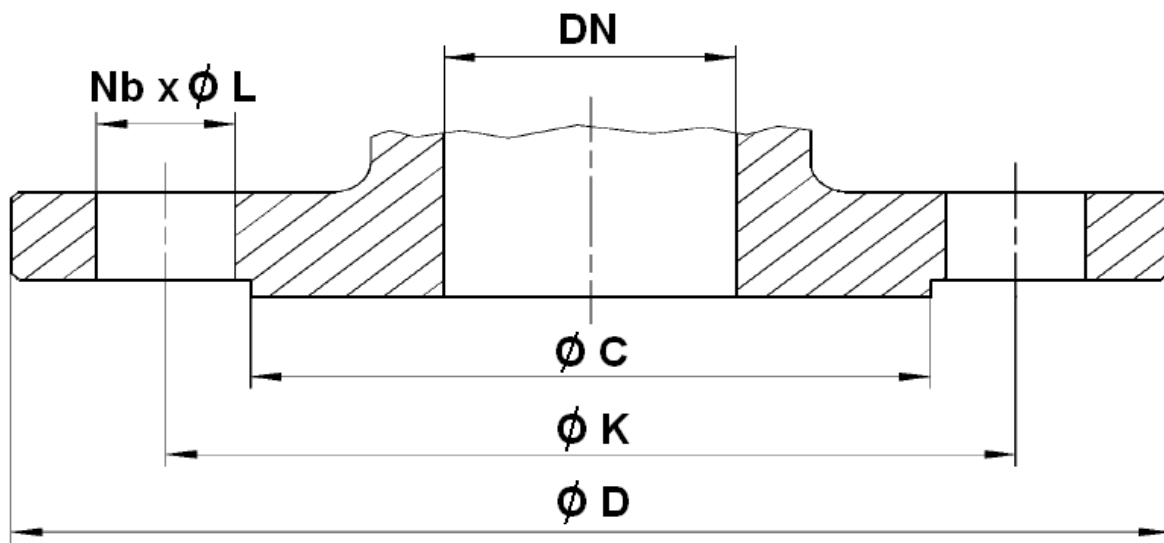

Ref.	DN	15	20	25	32	40	50	65	80	100	125	150	200
479	Ø C	46	56	65	76	84	99	118	132	156	184	211	266
	Ø D	95	105	115	140	150	165	185	200	220	250	285	340
	Ø K	65	75	85	100	110	125	145	160	180	210	240	295
	Nb x Ø L	4 x 14	4 x 14	4 x 14	4 x 19	4 x 19	4 x 19	4 x 19	4 x 19	8 x 19	8 x 19	8 x 19	8 x 23

CAST IRON GLOBE VALVE HIGH TEMPERATURE PN16**STANDARDS :**

- Fabrication according to ISO 9001 :2015 and ISO 14001 : 2015
- DIRECTIVE 2014/68/EU : CE N° 0062
Risk Category III module H
- Certificate 3.1 on request
- Tests according to EN 12266-1, rate A
- Length according to EN 558 series 1 (DIN 3202 F1)
- Flanges R.F. according to EN 1092-2 PN16
- Approval certificate Polish **PZH**
- Russian certification TRCU (marking and declaration EAC on request)

ADVICE : Our opinion and our advice are not guaranteed and Lauridsen Group shall not be liable for the consequences of damages. The customer must check the right choice of the products with the real service conditions.

CAST IRON GLOBE VALVE HIGH TEMPERATURE PN16

INSTALLATION INSTRUCTIONS

GENERAL GUIDELINES :

- Ensure that the valves to be used are appropriate for the conditions of the installation (type of fluid, pressure and temperature).
- Be sure to have enough valves to be able to isolate the sections of piping as well as the appropriate equipment for maintenance and repair.
- Ensure that the valves to be installed are of correct strength to be able to support the capacity of their usage.
- **Installation of all circuits should ensure that their function can be automatically tested on a regular basis (at least two times a year).**

INSTALLATION INSTRUCTIONS :

- **Before installing the valves, clean and remove any objects from the pipes** (in particular bits of sealing and metal) which could obstruct and block the valves.
- **Ensure that both connecting pipes either side of the valve (upstream and downstream) are aligned (if they're not, the valves may not work correctly).**
- **Make sure that the two sections of the pipe (upstream and downstream) match, the valve unit will not absorb any gaps. Any distortions in the pipes may affect the tightness of the connection, the working of the valve and can even cause a rupture.** To be sure, place the kit in position to ensure the assembling will work.
- **If sections of piping do not have their final support in place, they should be temporarily fixed. This is to avoid unnecessary strain on the valve.**
- Tighten the bolts in cross.
- It's recommended to operate the valve (open and close) 1 to 2 times per year
- Tighten the gland packing at the first start of the installation (with a moderate torque) so that there's no leakage and the handwheel is easy to operate.
- Do not use tools to operate the handwheel