

3 PIECES STAINLESS STEEL BALL VALVE FLANGED PN 40 DIRECT MOUNTING

3 pieces stainless steel ball valve with full bore for Chemical industries, petrochemical industries, hydraulic installation, heating, water distribution, compressed air.

Fugitive emission according to TA LUFT for an excellent tightness on the stem and to prevent external leakage.

PTFE filled with graphite packing, FKM O ring gasket and PTFE filled with stainless steel seat.

Compatible with explosive atmosphere, ATEX Zone 1&21 and Zone 2&22 thanks to the antistatic device.

Thanks to the ISO 5211 plate, an actuator can be installed on the valve.



Certificate

3.1



Lloyd's
Register
PED/2014/68/UE

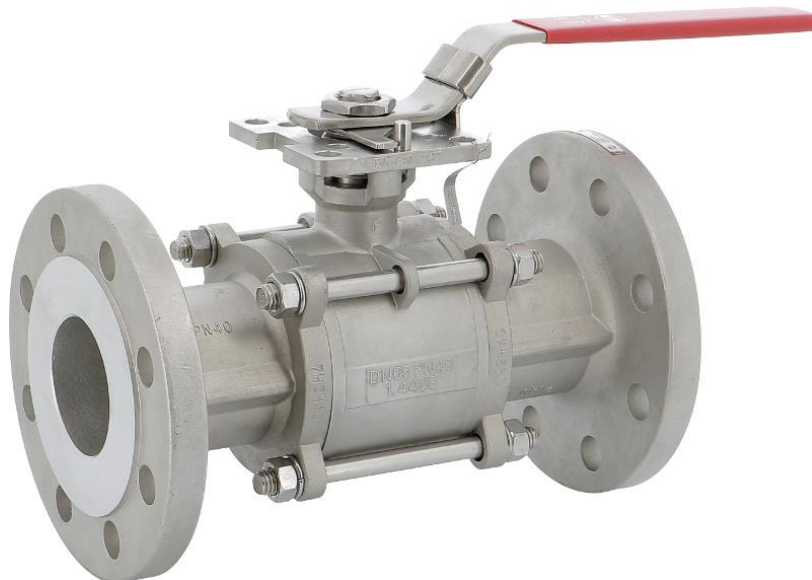

Size : DN15 to DN100

Connection : Flanged PN40 RF

Min Temperature : -30°C

Max Temperature : +220°C

Max Pressure : 40 bars

Specifications : ATEX

ISO 5211 mounting pad

Anti blow-out stem, full bore

Fugitive Emissions TA LUFT

PTFE filled with stainless steel seat

Materials : Stainless Steel EN 1.4408

3 PIECES STAINLESS STEEL BALL VALVE FLANGED PN 40 DIRECT MOUNTING

SPECIFICATIONS :

- Full bore
- Anti blow-out stem
- Special gland pack with elastic washer
- Antistatic device from DN15 to 32, double antistatic device (ball between body-stem and ball-stem) from DN40 to 100
- PTFE filled with stainless steel seat
- Locking device
- Blue handle cover possible
- ISO 5211 mounting pad
- 3 pieces type

USE :

- Chemical and pharmaceutical industries, petrochemical industries, hydraulic installation, compressed air
- Steam : 18 bars maximum
- Vacuum : 10⁻² torr
- Min and Max Temperature Ts : -30°C to + 220°C
- Max Pressure Ps : 40 bars (see graph)

PRESSURE / TEMPERATURE GRAPH :

Pressure (Bar)

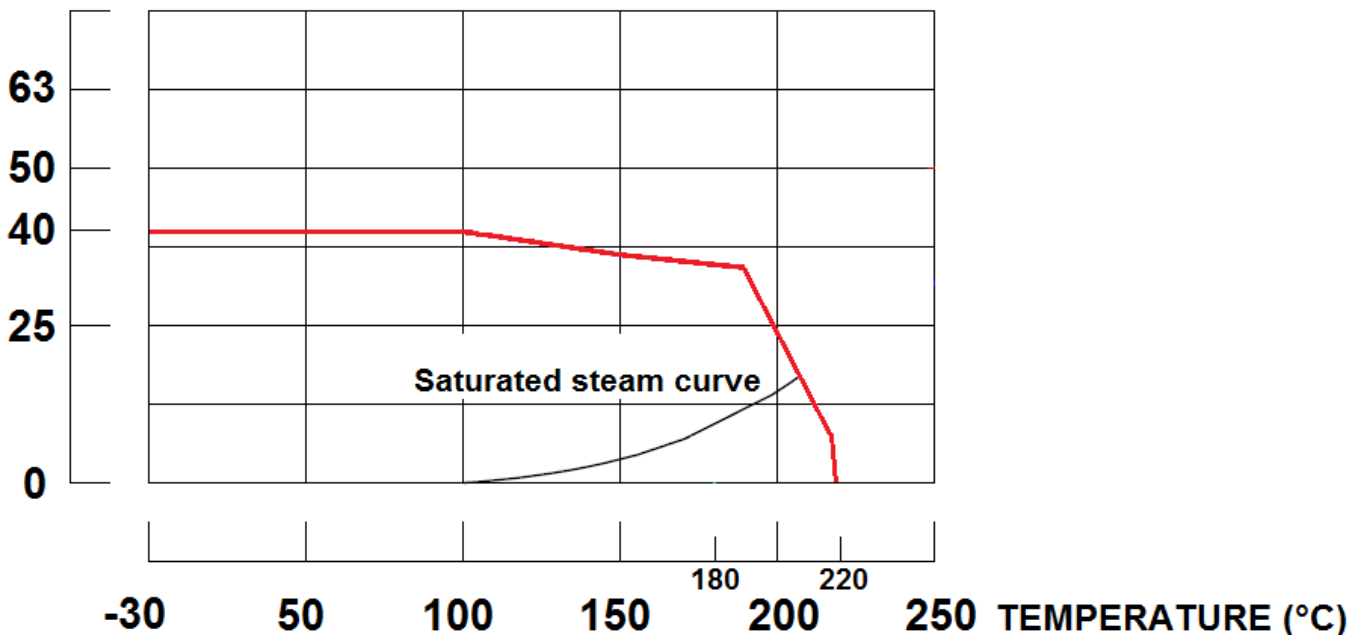

TORQUE VALUES (in Nm without safety coefficient) :

DN	15	20	25	32	40	50	65	80	100
Torque (Nm)	7.6	14.5	21	25	35	60	80	88	190

3 PIECES STAINLESS STEEL BALL VALVE FLANGED PN 40 DIRECT MOUNTING
BOLT TIGHTENING TABLE (in Nm):

DN	15	20	25	32	40	50	65	80	100
Torque (Nm)	6.9	9.8	9.8	11.8	15.7	20.6	54.9	73.5	94.1

FLOW COEFFICIENT Kvs (M3 / h):

DN	15	20	25	32	40	50	65	80	100
Kvs (m3/h)	31.3	57.9	94.3	157.9	227.9	414.8	720.2	1091	1754

RANGE :

- 3 pieces stainless steel ball valve **Ref. 711** from DN 15 to DN 100
- Blue handle cover **Ref. 9830432-9830436** from DN 15 to DN 100

ENDS :

- Flanges R.F. PN40

3 PIECES STAINLESS STEEL BALL VALVE FLANGED PN 40 DIRECT MOUNTING

MATERIALS :

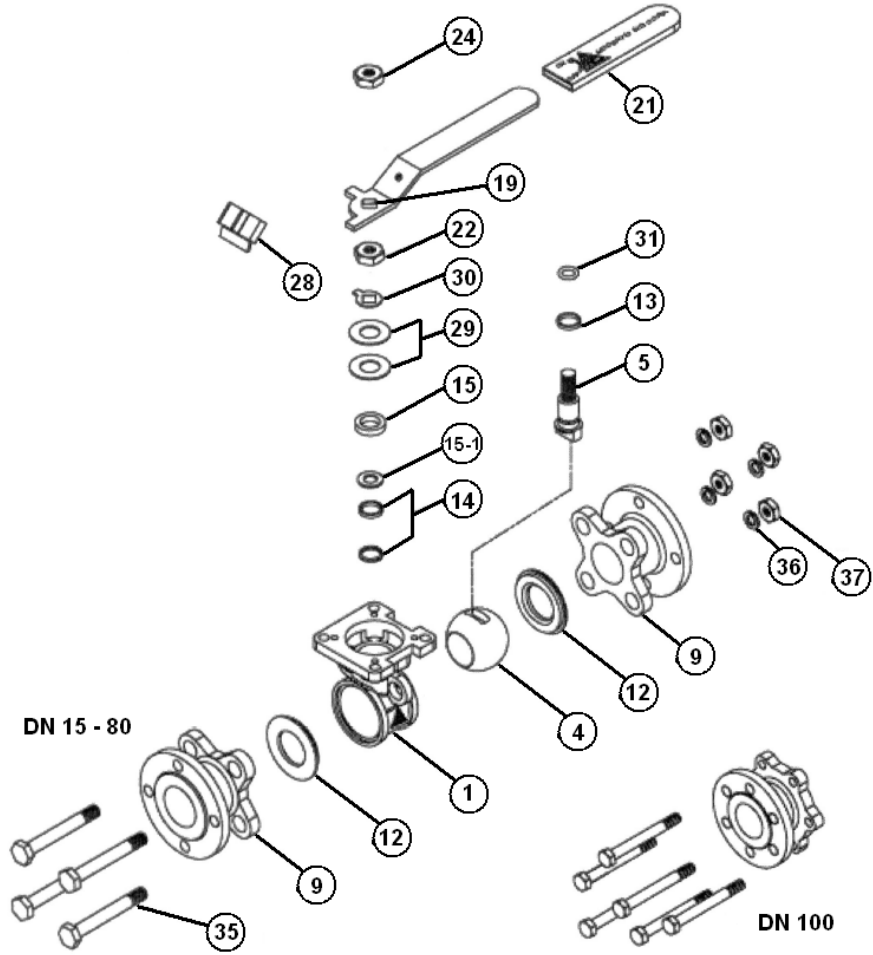

Item	Designation	Materials
1	Body	EN 1.4408
4	Ball	
5	Stem	AISI 316
9	Ends	EN 1.4408
12*	Seat	PTFE with 50% AISI 316
13*	Thrust washer	PTFE with 25% grafoil
14*	Stem packing	PTFE with 25% grafoil
15	Gland bush	AISI 304
19	Handle	
21	Handle cover	Plastic
22	Stem nut	AISI 304
24	Handle nut	
28	Locking device	
29	Elastic washer	AISI 301
30	Tab washer	AISI 304
31*	O-ring	PTFE with 25% grafoil
35	Body bolt	AISI 304
36	Bolt washer	
37	Bolt nut	

(* : Included in gaskets kit)

3 PIECES STAINLESS STEEL BALL VALVE FLANGED PN 40 DIRECT MOUNTING

SIZE (in mm) :

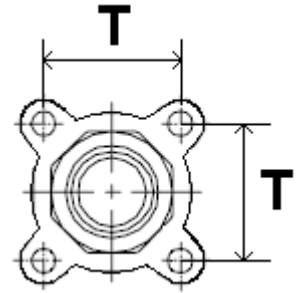
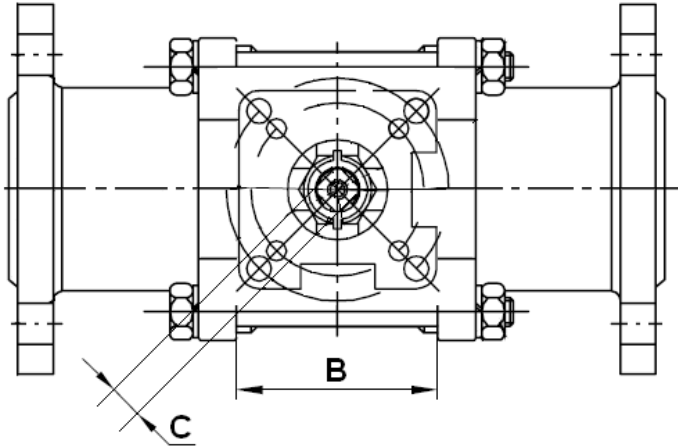

DN 15 – 80

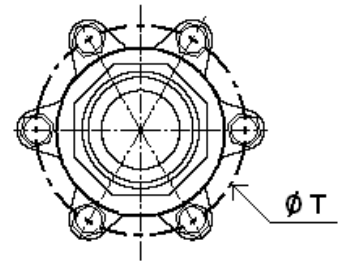
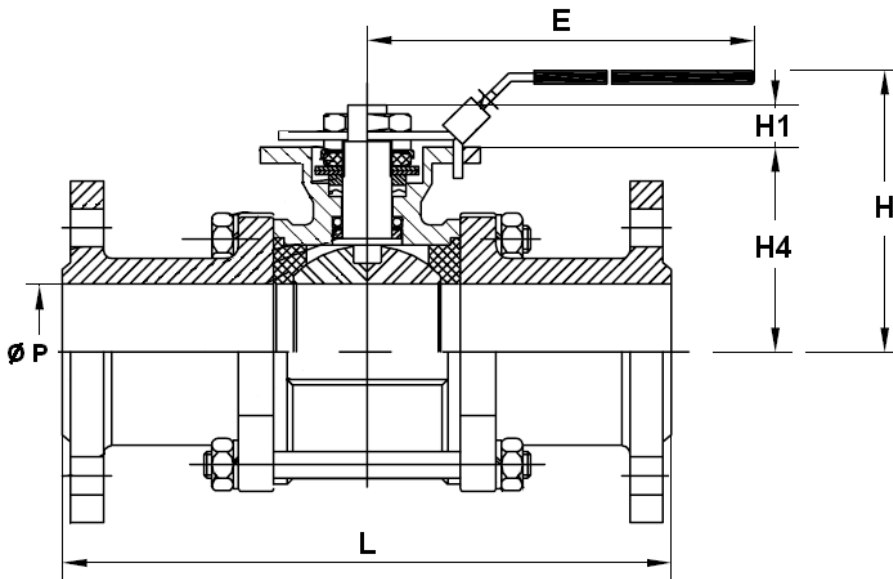

DN 100

Stem size :

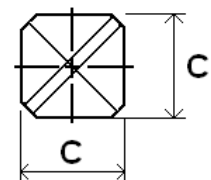

DN	15	20	25	32	40	50	65	80	100
Ø P	15	20	25	32	38	50	65	80	100
L	130	150	160	180	200	230	290	310	350
B	22.5	27.5	34	42.5	52	63.5	85.5	102	129
E	112	112	136	185	197.9	197.9	264	264	325
H	73	80.8	90.5	98.7	115.3	124	155	208.5	216.7
H1	8.5	8.5	11.4	11.4	14	13.7	18	18	23
H4	37	45	53.5	59	74.8	83.5	108.8	118.3	153.8
C	9	9	9	9	14	14	17	17	17
T	31	35	41	49	59	71	91	107	195
Weight (Kg)	2.04	2.9	3.66	5.4	6.76	9.75	15.36	21.33	36.70
Ref.	711015	711020	711025	711032	711040	711050	711065	711080	711100

3 PIECES STAINLESS STEEL BALL VALVE FLANGED PN 40 DIRECT MOUNTING

ISO MOUNTING PAD AND STEM SIZE (in mm) :

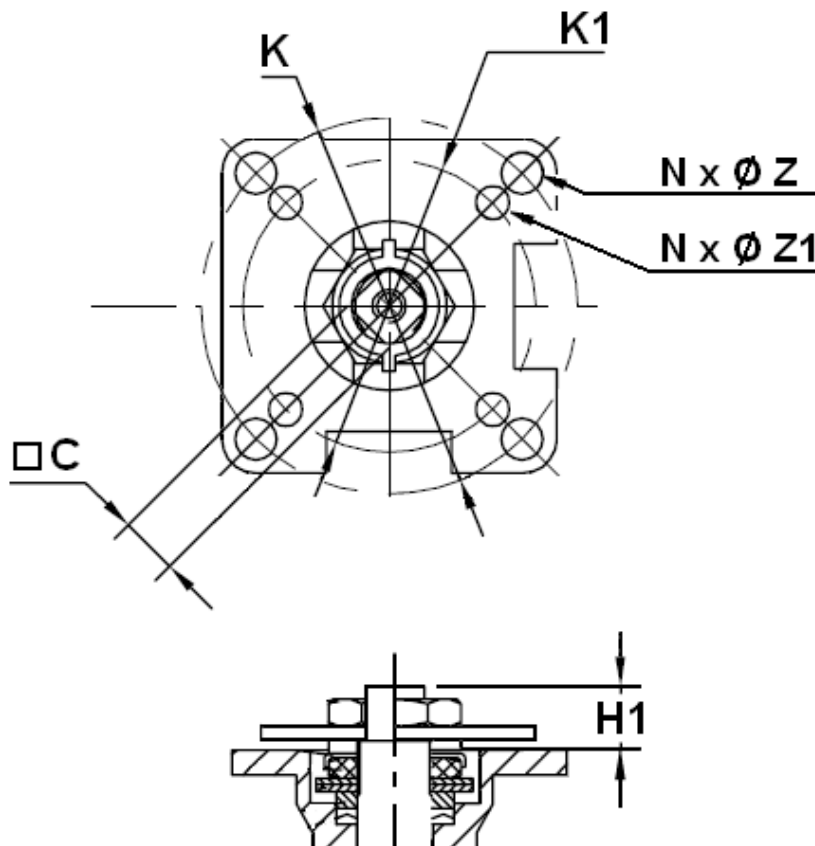

DN	15	20	25	32	40	50	65	80	100
C	9	9	9	9	14	14	17	17	17
H1	8.5	8.5	11.4	11.4	14	13.7	18	18	23
Ø K	50	50	50	50	70	70	102	102	102
ISO	F05	F05	F05	F05	F07	F07	F10	F10	F10
N x Ø Z	4 x 7	4 x 7	4 x 7	4 x 7	4 x 9	4 x 9	4 x 11	4 x 11	4 x 11
Ø K1	36	36	36	36	50	50	70	70	70
ISO 1	F03	F03	F03	F03	F05	F05	F07	F07	F07
N x Ø Z1	4 x 6	4 x 6	4 x 6	4 x 6	4 x 7	4 x 7	4 x 9	4 x 9	4 x 9

3 PIECES STAINLESS STEEL BALL VALVE FLANGED PN 40 DIRECT MOUNTING

FLANGES SIZE (in mm) :

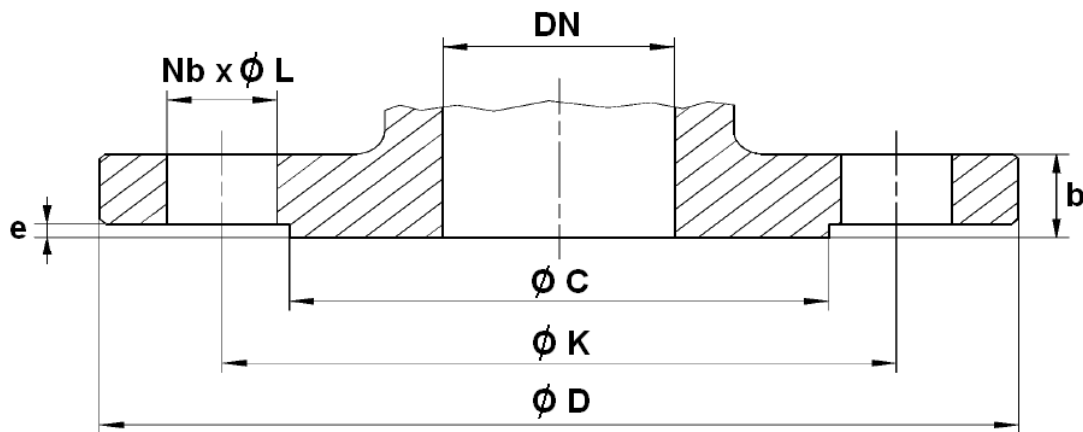

DN	15	20	25	32	40	50	65	80	100
Ø C	45	58	68	78	88	102	122	138	162
Ø D	95	105	115	140	150	165	185	200	235
Ø K	65	75	85	100	110	125	145	160	190
Nb x Ø L	4 x 14	4 x 14	4 x 14	4 x 18	4 x 18	4 x 18	8 x 18	8 x 18	8 x 22
b	16	18	18	18	18	20	22	24	24
e	2	2	2	2	3	3	3	3	3

3 PIECES STAINLESS STEEL BALL VALVE FLANGED PN 40 DIRECT MOUNTING

STANDARDS :

- Manufacturer certified ISO 9001 : 2015
- DIRECTIVE 2014/68/EU : CE N° 0038
Risk Category III Module H
- Certificate 3.1 on request
- Construction according to EN 12516
- Pressure tests according to EN 12266-1, rate A
- Flanges according to EN 1092-1 PN40
- ISO 5211 mounting pad
- Length according to EN 558 series 1 (NF 29355 DIN 3202 F1)
- ATEX Group II Category 2 G/2D Zone 1 & 21 Zone 2 & 22 (optional marking) according directive 2014/34/EU
- Tightness on stem according to TA LUFT VDI 2440/3.3.1.3

ADVICE : Our opinion and our advice are not guaranteed and Lauridsen Group shall not be liable for the consequences of damages. The customer must check the right choice of the products with the real service conditions.