

RUBBER EXPANSION JOINT TEGUFLEX® PHP DOUBLE RED EPDM HT

Rubber expansion joint Teguflex EPDM red with swiveling flanges to absorb vibrations and noises on hot water, cooling water with salt solutions, chlorine solutions, esters and ketones.

Not advisable for hydrocarbons, greasy product and abrasive products.

Body in EPDM and carbon steel dichromate zinc plated.

For linear and angular compansion.

130 mm long for all DN.



Size : DN25 to DN300

Connection : Flanges PN10/16

Min Temperature : -35°C

Max Temperature : +130°C

Max Pressure : 16 Bars

Specifications : Absorb vibrations and noise

Linear and angular compansion

EPDM Tube

Materials : Dichromate zinc plated steel flanges

RUBBER EXPANSION JOINT TEGUFLEX® PHP DOUBLE RED EPDM HT

SPECIFICATIONS :

- Absorb vibration, noises and expansion
- Linear and angular compansion
- Inner tube EPDM HT
- 130 mm length
- Dichromate zinc plated steel swiveling flanges PN10/16 up to DN150, PN10 over
- On request, PN6, PN16 and Class 150 PN20 flanges
- AISI 316 flanges on request
- AISI 316 Ti vacuum ring on request (Ref.9815050 to 9815300)
- Inner liner PTFE on request (movements allowed by the expansion joints are then reduced by 50 % and pressure max is 6 bars)
- Bursting pressure >50 bar at 20°C
- Test pressure 25 bar at 20°C

USE :

- Hot water, heating, steam, hot air
- Not advisable for hydrocarbons, greasy product and abrasive products
- Min and max temperature Ts : - 35°C to + 130°C
- Max pressure Ps : 16 bars at 100°C up to DN150 (6 bars with PTFE lining)
 - 16 bars at 70°C from DN200 to DN300
 - 10 bars at 130°C up to DN150
 - 6 bars at 130°C from DN200 to DN300

PRESSURE / TEMPERATURE GRAPH (STEAM EXCLUDED) :

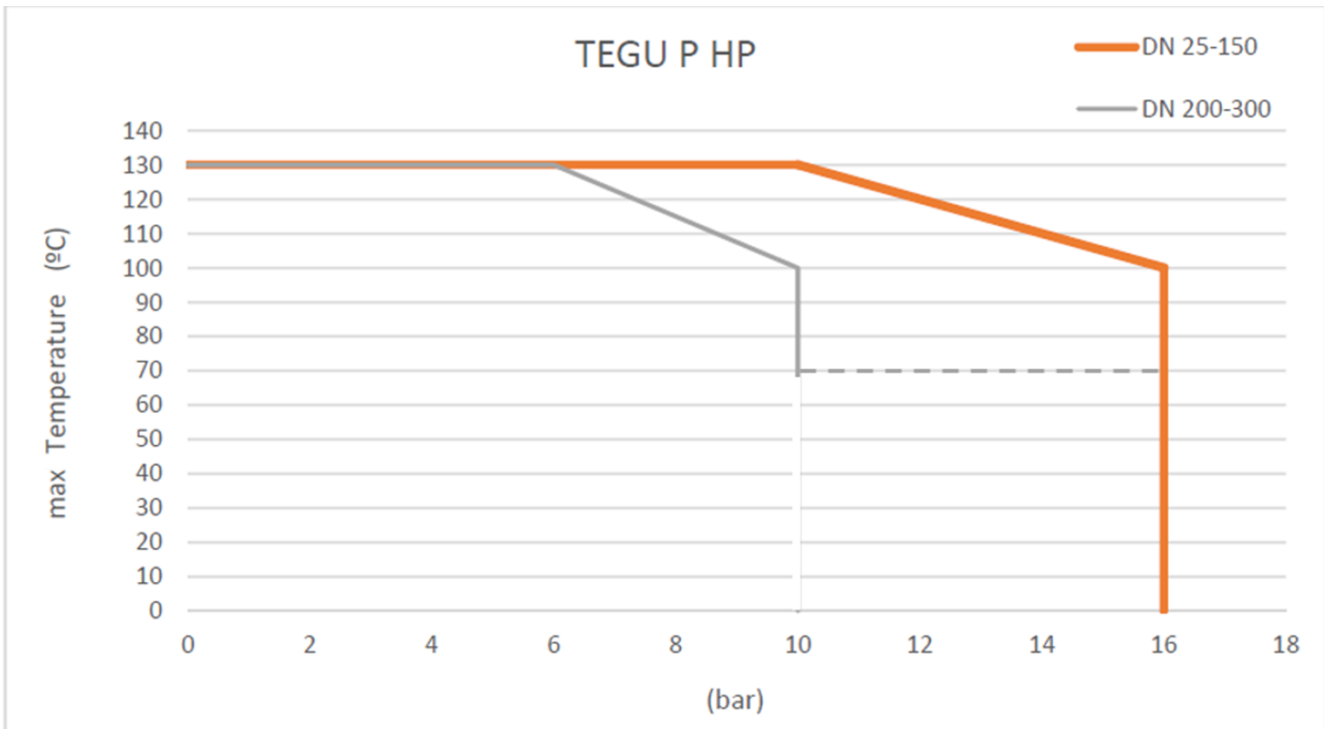

MAXIMUM VACUUM :

DN	25/32	40	50	65	80	100	125	150	200	250	300
Vacuum (bar)	-0.8	-0.8	-0.7	-0.6	-0.5	-0.5	-0.4	-0.3	-0.3	-0.2	-0.2

RUBBER EXPANSION JOINT TEGUFLEX® PHP DOUBLE RED EPDM HT

RANGE :

- EPDM HT expansion joint with dichromate zinc plated steel flanges PN10/16 from DN 25 to DN 150, PN10 over **Ref. 1562**
- **On Request :**

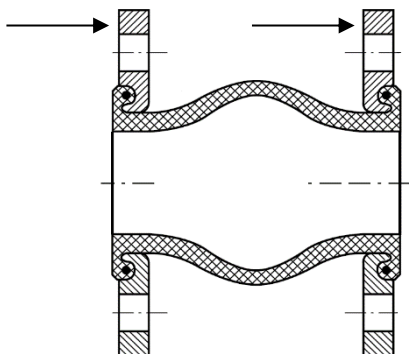

- AISI 316 flanges

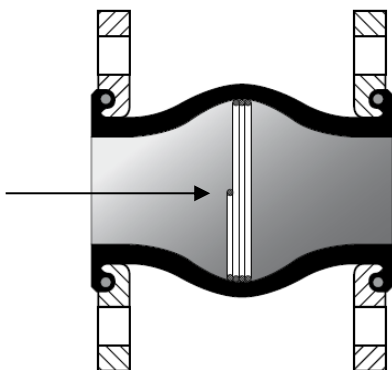

- AISI 316 Ti vacuum ring (vacuum up to -1 bar) Ref.9815050 to 9815300

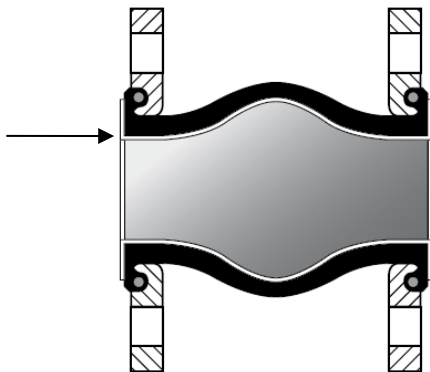

- Inner liner PTFE (movements allowed by the expansion joints are then reduced by 50 % and pressure max is 6 bars)

RUBBER EXPANSION JOINT TEGUFLEX® PHP DOUBLE RED EPDM HT

MATERIALS :

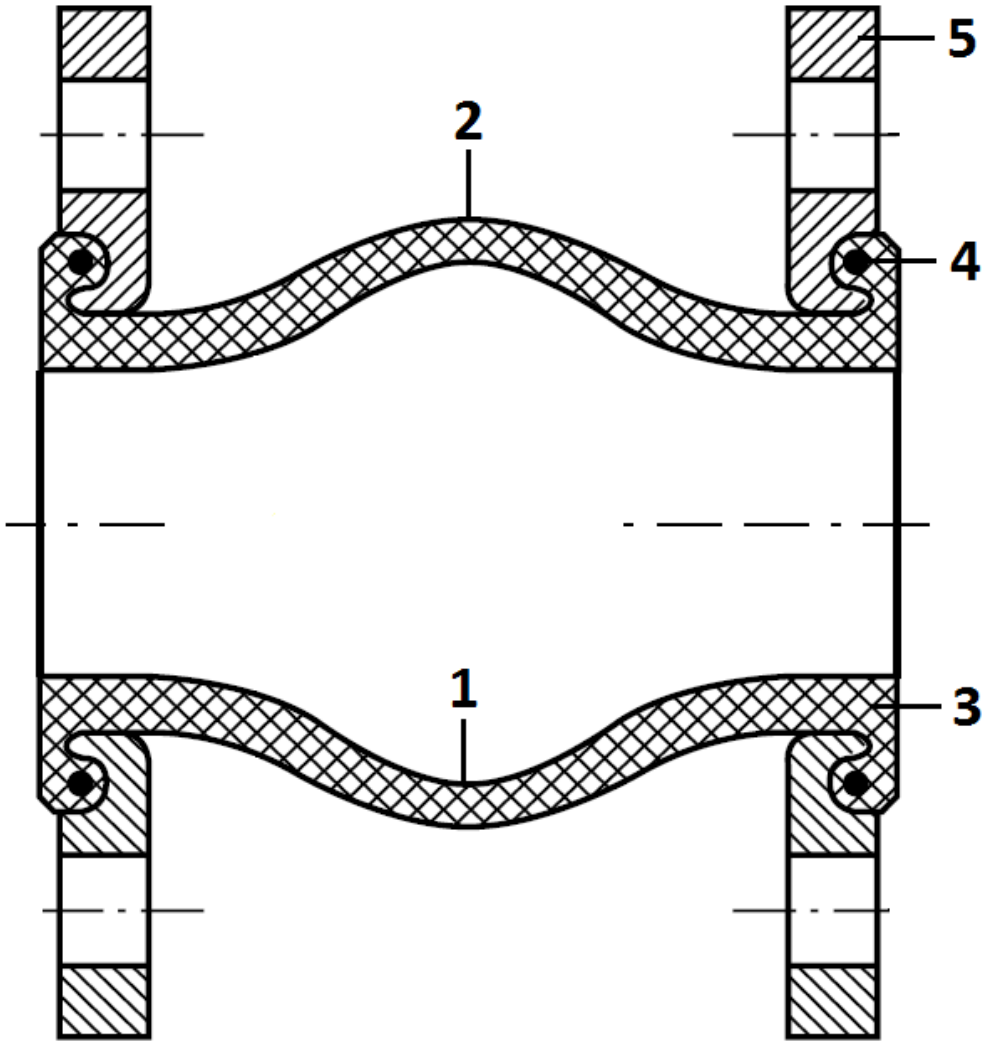

Item	Designation	Materials
1	Inner tube	EPDM HT
2	Outer cover	EPDM HT
3	Reinforcement	Aramid
4	Brace	Carbon steel
5	Swiveling flanges	Dichromate zinc plated steel

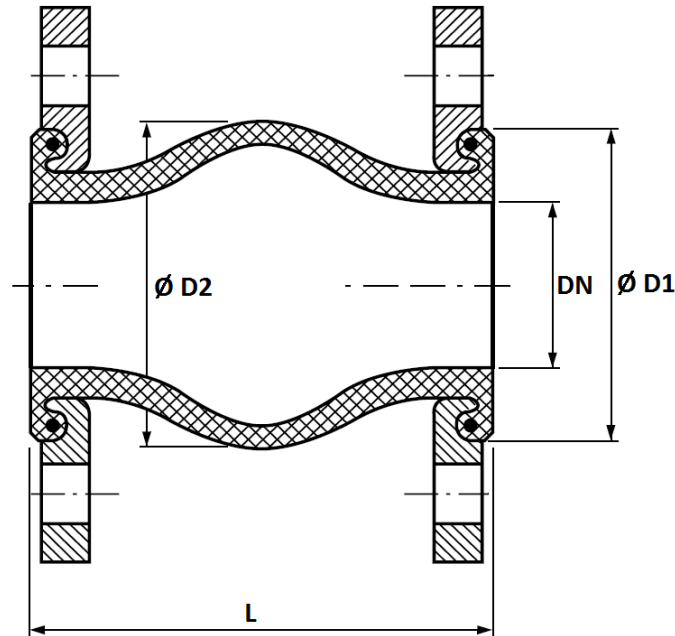
RUBBER EXPANSION JOINT TEGUFLEX® PHP DOUBLE RED EPDM HT
SIZE (in mm) :

DN	32	40	50	65	80	100	125	150	200	250	300
L	130	130	130	130	130	130	130	130	130	130	130
Ø D1	72	80	90	105	120	140	165	190	240	290	340
Ø D2	77	85	95	110	125	145	170	195	245	295	345
Weight (Kg)	2.8	3.3	3.7	4.8	5.3	6.2	8.2	11.2	16.8	21.6	30.1
Ref.	1562032	1562040	1562050	1562065	1562080	1562100	1562125	1562150	1562200	1562250	1562300

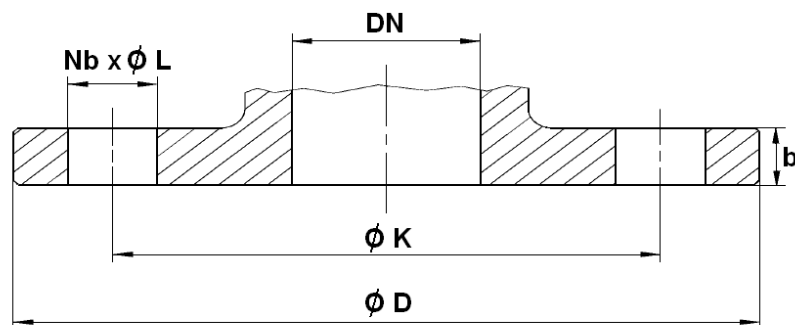
STANDARD FLANGES PN10 (PN10/16 UP TO DN150) SIZE (in mm) :

DN	25	32	40	50	65	80	100	125	150	200	250	300
Ø D	115	140	150	165	185	200	220	250	285	340	395	445
Ø K	85	100	110	125	145	160	180	210	240	295	350	400
Nb x Ø L	4x14	4 x 18	4 x 18	4 x 18	4 x 18	8 x 18	8 x 18	8 x 18	8 x 22	8 x 22	12 x 22	12 x 22
b	13.8	13.8	14	14.1	14.4	14.8	15.2	16	17.8	20.2	22.6	26.5

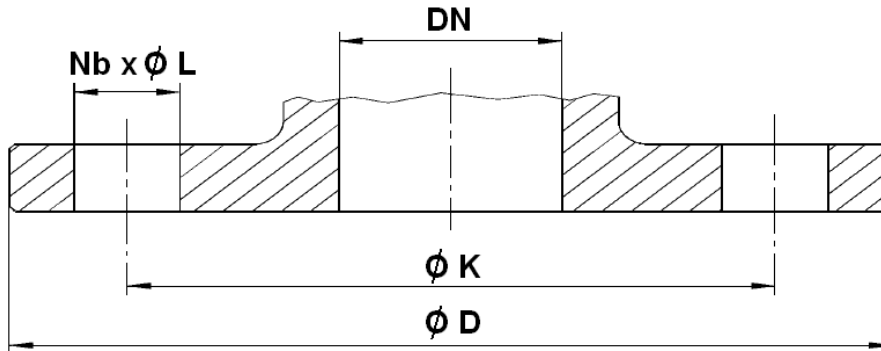
RUBBER EXPANSION JOINT TEGUFLEX® PHP DOUBLE RED EPDM HT
SIZE OF FLANGES ON REQUEST :

PN6 FLANGES (in mm) :

DN	25	32	40	50	65	80	100	125	150	200	250	300
Ø D	100	120	130	140	160	190	210	240	265	320	375	440
Ø K	75	90	100	110	130	150	170	200	225	280	335	395
Nb x Ø L	4 x 11	4 x 14	4 x 14	4 x 14	4 x 14	4 x 18	4 x 18	8 x 18	8 x 18	8 x 18	12 x 18	12 x 22

PN16 FLANGES (in mm) :

DN	200	250	300
Ø D	340	405	460
Ø K	295	355	410
Nb x Ø L	12 x 22	12 x 26	12 x 26

Class 150 PN20 FLANGES (in mm) :

DN (mm)	25	32	40	50	65	80	100	125	150	200	250	300
NPS (")	1"	1"1/4	1"1/2	2"	2"1/2	3"	4"	5"	6"	8"	10"	12"
Ø D	108	117	127	152	178	190	229	254	279	343	406	483
Ø K	79.4	88.9	98.4	120.6	139.7	152.4	190.5	215.9	241.3	298.4	361.9	431.8
Nb x Ø L	4 x 15.9	4 x 15.9	4 x 15.9	4 x 19	4 x 19	4 x 19	8 x 19	8 x 22.2	8 x 22.2	8 x 22.2	12 x 25.4	

RUBBER EXPANSION JOINT TEGUFLEX® PHP DOUBLE RED EPDM HT

MOVEMENTS (in mm) :

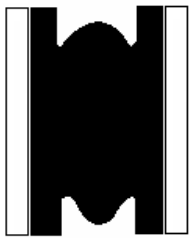

Compansion

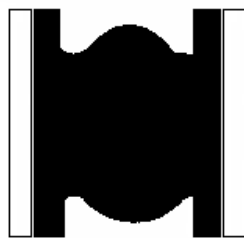

Expansion

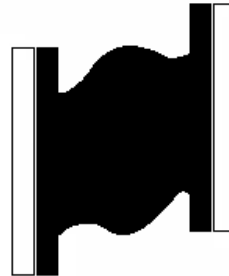

Lateral

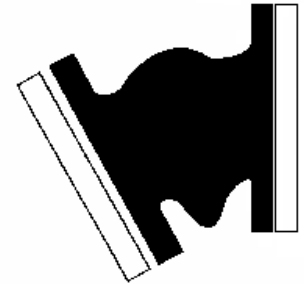

Angular

DN	25-50	65	80	100	125	150	200	250	300
Compansion	30	30	30	30	30	30	30	30	30
Expansion	20	20	20	20	20	20	20	20	20
Lateral	20	20	20	20	20	20	20	20	20
Angular	35°	30°	30°	25°	25°	15°	15°	10°	10°

Maximum movements can't be applied simultaneously.

For example, with an expansion of 15mm, the maximum lateral movement will be 8 mm :

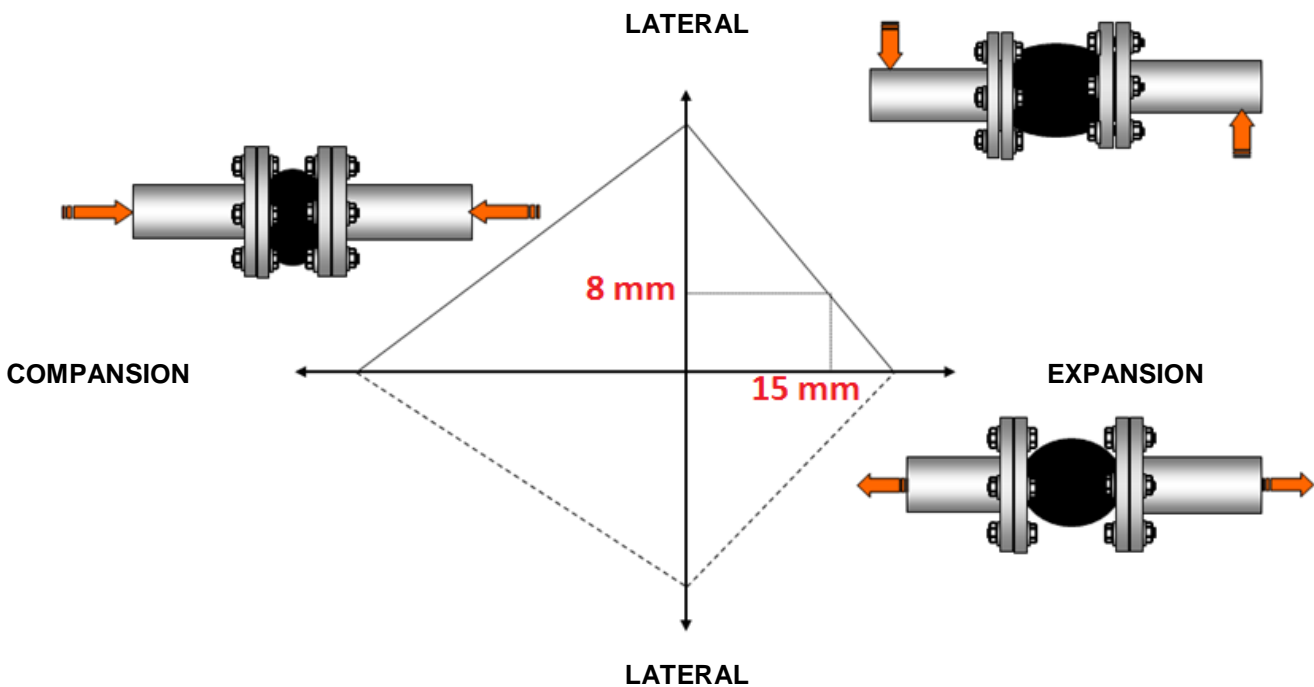

RUBBER EXPANSION JOINT TEGUFLEX® PHP DOUBLE RED EPDM HT

MARKING :STANDARDS :

- Manufacturer certified ISO 9001 : 2015 and ISO 14001 : 2015
- DIRECTIVE 2014/68/EU : CE N° 0056
Risk category III Module H
- Flanges according to EN 1092-1 PN10/16
- **Marine ABS** Product type approved, Certificate N° 15LD1374164PDA
- **Marine DNV-GL** type Approval certificate, Certificate N° TAP000018F

ADVICE : Our opinion and our advice are not guaranteed and Lauridsen Group shall not be liable for the consequences of damages. The customer must check the right choice of the products with the real service conditions.