

LOCKABLE BRASS BALL VALVE SFERALOCK (556 - 557)



Size : DN 1/4" to 2"
Ends : Female - female BSP
Min Temperature : - 10°C
Max Temperature : + 120°C
Max Pressure : 40 Bars (up to DN 1")
Specifications : With locking device (4 safety points)
Position indicator
Full bore

Materials : Brass CW617N

LOCKABLE BRASS BALL VALVE SFERALOCK (556 - 557)

SPECIFICATIONS :

- With locking device (4 safety points)
- Inviolable stem
- Position indicator
- Full bore
- Solid ball
- NBR O ring on stem
- No anti blow out stem
- Blue flat steel handle
- Threaded BSP cylindrical ends

USE :

- For all common fluids
- Min Temperature Ts : - 10 °C
- Max Temperature Ts : + 120°C
- Max Pressure Ps : 40 bars up to DN 1", 30 bars for DN 1"1/4, 25 bars for DN 1"1/2 and 20 bars for DN 2" (see graph)
- Compressed air : 10 bars maxi for **Ref.557**
20 bars maxi for **Ref.556**

PRESSURE / TEMPERATURE GRAPH (STEAM EXCLUDED) :

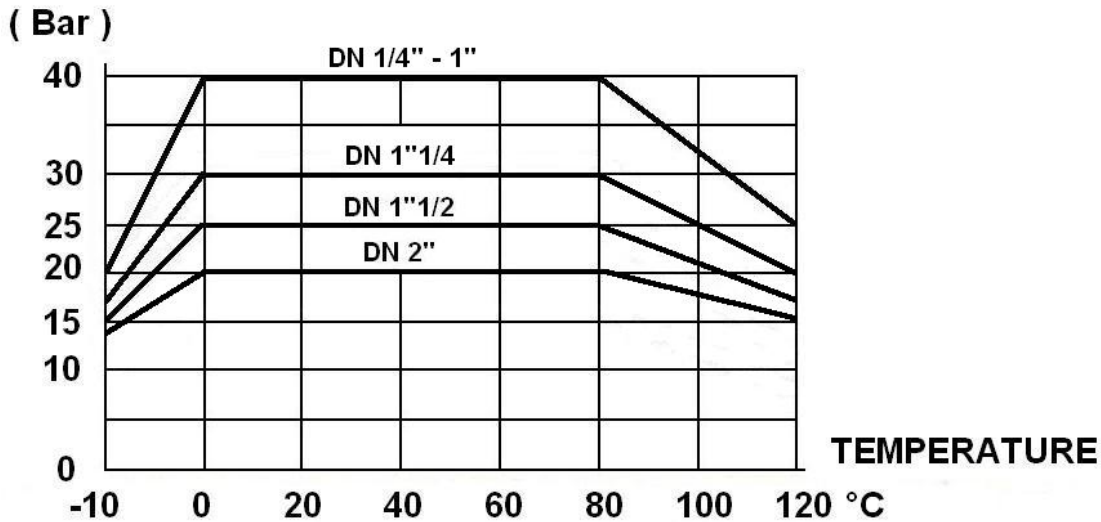

RANGE :

- Female / Female threaded BSP **Ref. 556** from DN 1/4" to DN 2"
- Female / Female threaded BSP with exhaust hole **Ref. 557** from DN 1/4" to DN 1"

LOCKABLE BRASS BALL VALVE SFERALOCK (556 - 557)

MATERIALS FOR STANDARD TYPE (REF.556) :

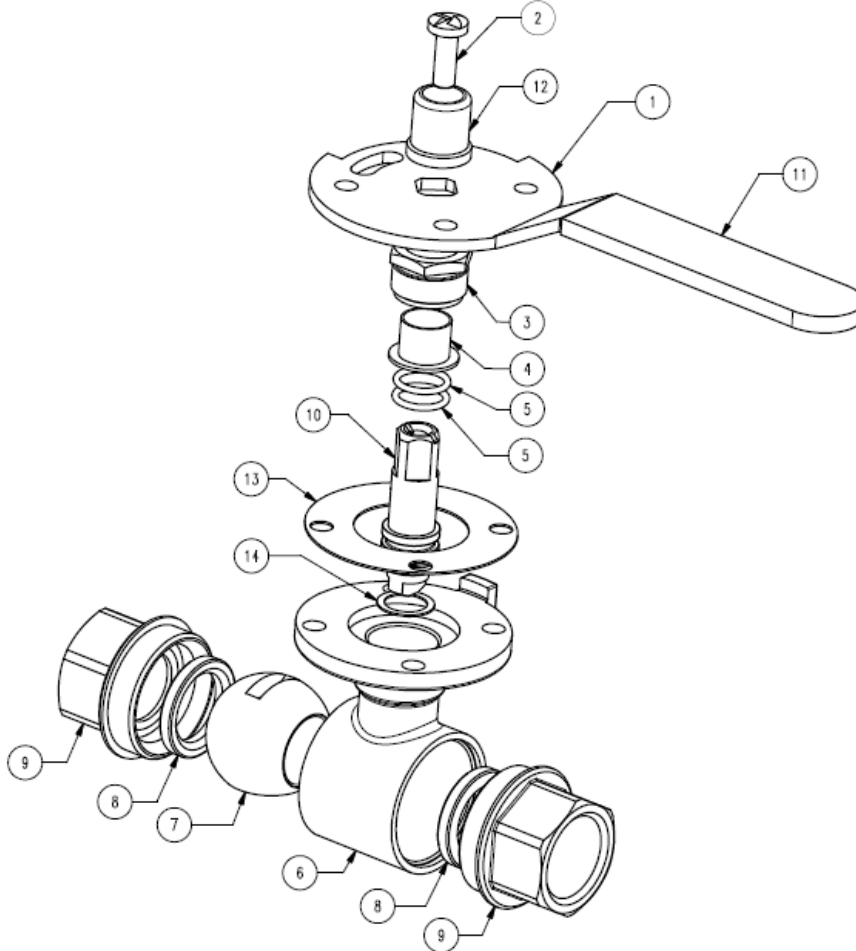

Item	Designation	Materials 556
1	Handle	Galvanized steel
2	Screw handle	Stainless steel
3	Packing nut	Brass CW614N according to EN12164
4	Ring	PTFE
5	O ring	NBR
6	Body	Brass CW617N according to EN12165 nickel
7	Ball	Brass CW617N according to EN12165 chromed
8	Seat	PTFE
9	Bonnet	Brass CW617N according to EN12165 nickel
10	Stem	Brass CW614N according to EN12164
11	Handle cover	Plastic
12	Screw protection	Brass CW614N according to EN12164 nickel
13	Position indicator	Aluminium
14	Ring	PTFE

LOCKABLE BRASS BALL VALVE SFERALOCK (556 - 557)

MATERIALS FOR FEMALE FEMALE WITH EXHAUST HOLE TYPE (REF.557) :

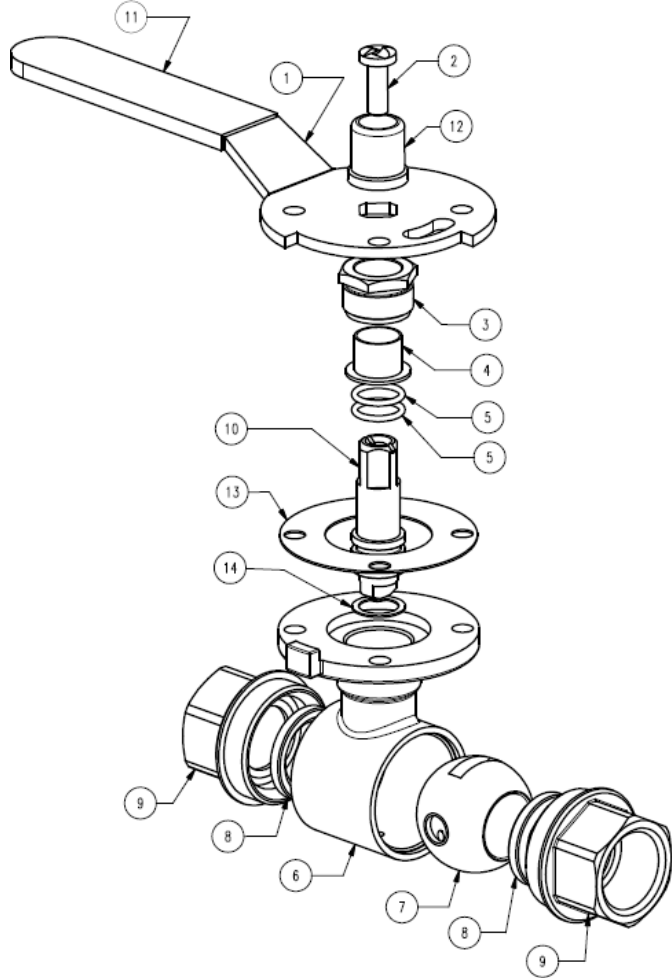

Item	Designation	Materials 557
1	Handle	Galvanized steel
2	Screw handle	Stainless steel
3	Packing nut	Brass CW614N according to EN12164
4	Ring	PTFE
5	O ring	NBR
6	Body	Brass CW617N according to EN12165 nickeled
7	Ball	Brass CW617N according to EN12165 chromed
8	Seat	PTFE
9	Bonnet	Brass CW617N according to EN12165 nickeled
10	Stem	Brass CW614N according to EN12164
11	Handle cover	Plastic
12	Screw protection	Brass CW614N according to EN12164 nickeled
13	Position indicator	Aluminium
14	Ring	PTFE

LOCKABLE BRASS BALL VALVE SFERALOCK (556 - 557)

SIZE STANDARD TYPE REF.556 (in mm) :

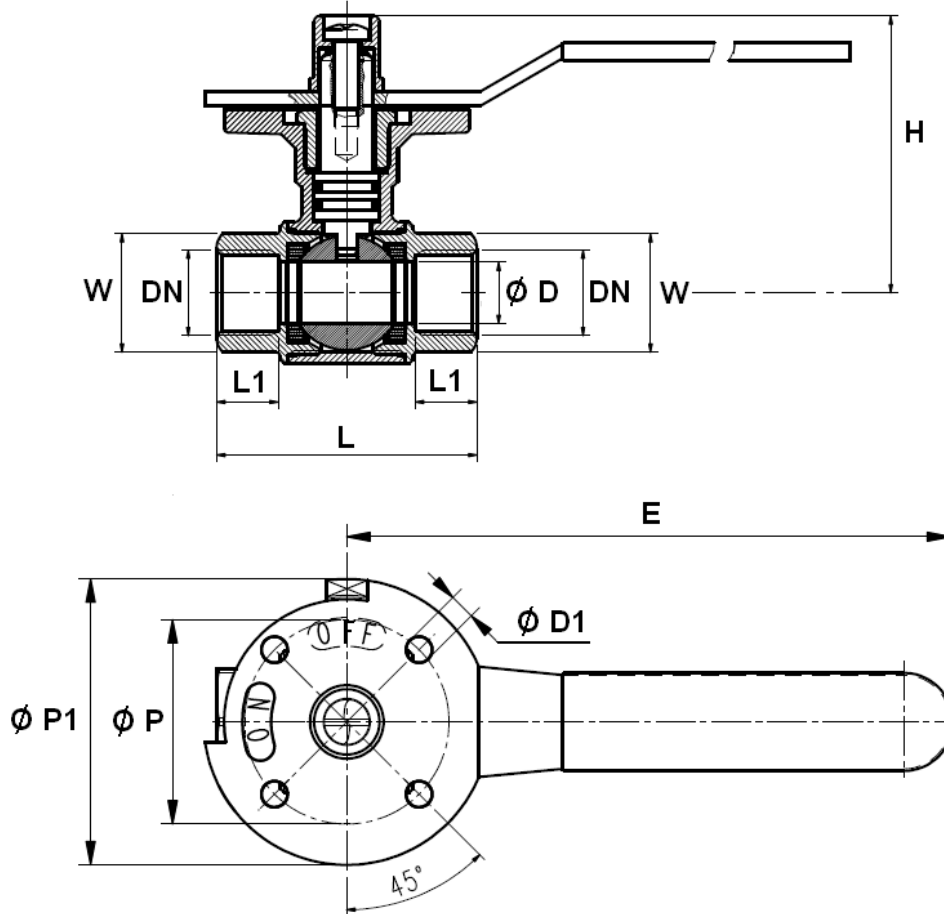

Ref.	DN	1/4"	3/8"	1/2"	3/4"	1"	1 1/4"	1 1/2"	2"
556	D	10	10	15	20	25	32	40	49
	D1	6.4	6.4	6.4	6.4	6.4	6.4	6.4	6.4
	L	63.5	63.5	63.5	72	86	96	107	124
	L1	15	15	15	17	20	22	22	26
	E	147.5	147.5	147.5	147.5	147.5	147.5	147.5	147.5
	H	67.5	67.5	67.5	71.5	75.5	79.5	91.5	97
	P	50	50	50	50	50	50	50	50
	P1	70	70	70	70	70	70	70	70
	W on flat	26	26	26	32	39	49	55	68
	Weight (in Kg)	0.705	0.682	0.657	0.789	1.022	1.302	1.746	2.398

LOCKABLE BRASS BALL VALVE SFERALOCK (556 - 557)

SIZE FOR FEMALE FEMALE WITH EXHAUST HOLE TYPE REF.557 (in mm) :

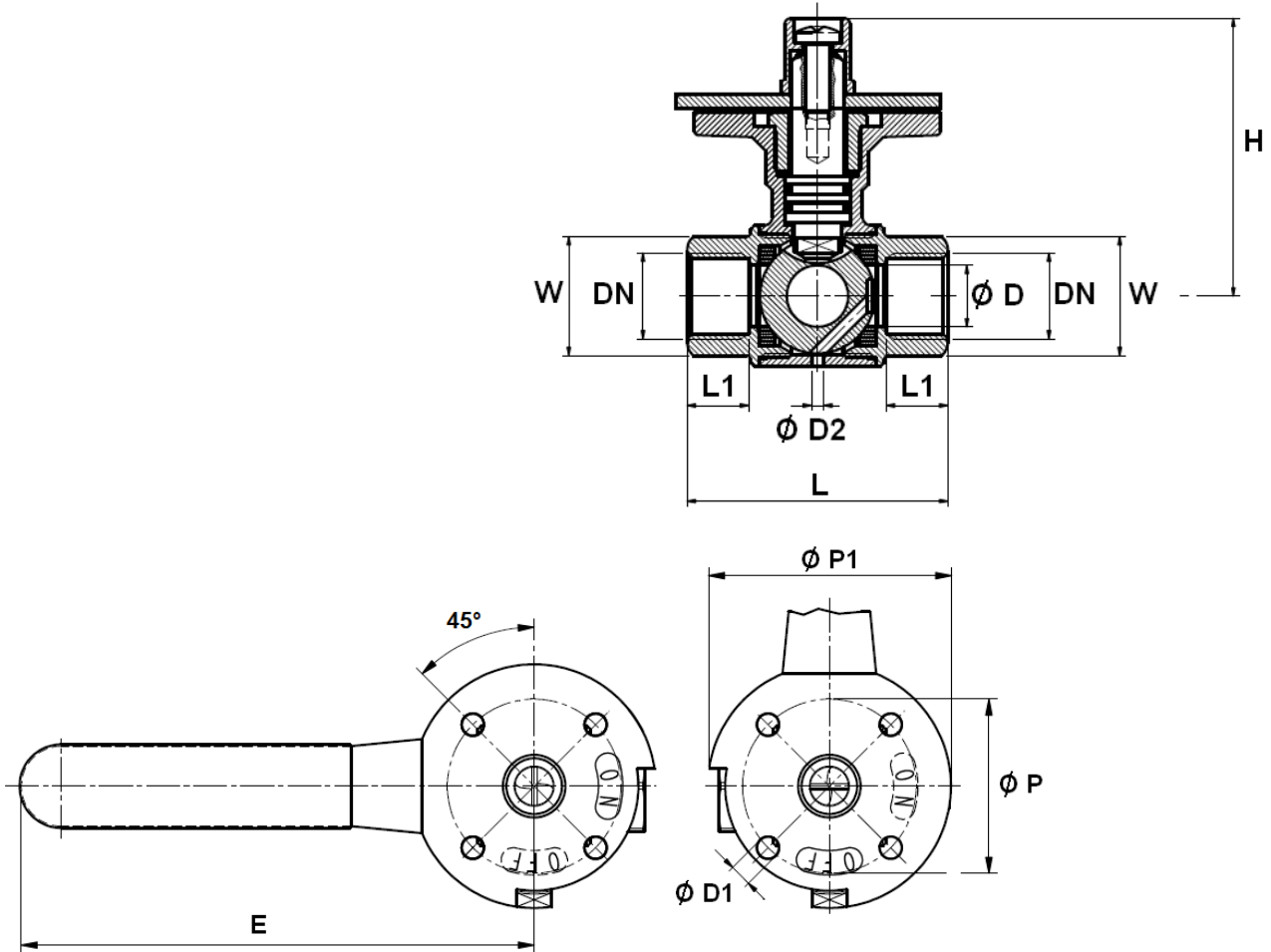

Ref.	DN	1/4"	3/8"	1/2"	3/4"	1"
557	ϕD	10	10	15	20	25
	$\phi D1$	6.4	6.4	6.4	6.4	6.4
	$\phi D2$	3	3	3	3	3
	L	63.5	63.5	63.5	72	86
	L1	15	15	15	17	20
	E	147.5	147.5	147.5	147.5	147.5
	H	67.5	67.5	67.5	71.5	75.5
	ϕP	50	50	50	50	50
	$\phi P1$	70	70	70	70	70
	W on flat	26	26	26	32	39
	Weight (Kg)	0.700	0.687	0.654	0.790	1

LOCKABLE BRASS BALL VALVE SFERALOCK (556 - 557)**STANDARDS :**

- Fabrication according to ISO 9001 : 2015
- DIRECTIVE 2014/68/EU : Products excluded from directive up to DN1" (Article 4, § 3)
Risk category I module A from DN1 "1/4 to DN2"
- Threaded BSP cylindrical ends according to ISO 228-1

ADVICE : Our opinion and our advice are not guaranteed and Lauridsen group shall not be liable for the consequences of damages. The customer must check the right choice of the products with the real service conditions.

LOCKABLE BRASS BALL VALVE SFERALOCK (556 - 557)**INSTALLATION INSTRUCTIONS****GENERAL GUIDELINES :**

- Ensure that the valves to be used are appropriate for the conditions of the installation (type of fluid, pressure and temperature).
- Be sure to have enough valves to be able to isolate the sections of piping as well as the appropriate equipment for maintenance and repair.
- Ensure that the valves to be installed are of correct strength to be able to support the capacity of their usage.
- Tighten the gland packing regularly to keep the stem in the right position
- **Installation of all circuits should ensure that their function can be automatically tested on a regular basis (at least two times a year).**

INSTALLATION INSTRUCTIONS :

- **Before installing the valves, clean and remove any objects from the pipes** (in particular bits of sealing and metal) which could obstruct and block the valves.
- **Ensure that both connecting pipes either side of the valve (upstream and downstream) are aligned (if they're not, the valves may not work correctly).**
- **Make sure that the two sections of the pipe (upstream and downstream) match, the valve unit will not absorb any gaps. Any distortions in the pipes may affect the tightness of the connection, the working of the valve and can even cause a rupture.** To be sure, place the kit in position to ensure the assembling will work.
- Before starting the fitting, ensure that the threads and tapping are clean.
- **If sections of piping do not have their final support in place, they should be temporarily fixed. This is to avoid unnecessary strain on the valve.**
- The theoretical lengths given by ISO/R7 for the tapping are typically longer than required, the length of the thread should be limited, and **check that the end of the tube does not press right up to the head of the thread.**
- For the sealing assembly valve piping, it is essential to use products that are compatible with the requirements of the French water agreement ACS : **plumbers hemp proscribed.**
- Position the pipe clips on both sides of the valve.
- If mounting on an air conditioning with PER tubing and hoses, it is necessary to support the tubes and hoses with the fixing to avoid strain on the valve.
- When screwing the valve, ensure that you only rotate on screwed side by the 6 ended side. Use an open ended spanner or an adjustable spanner and not a monkey wrench.
- **Never use a vice to tighten the fixings of the valve.**
- Do not over tighten the valve. Do not block with any extensions as it may cause a rupture or weakening of the casing.
- **In general, for all valves used in buildings and heating, do not tighten above a torque of 30 Nm.**

The advice and assembly instructions above do not conform to any guarantee.
The information is given in general. It states what must not and must be done.
It is provided to ensure the safety of the personnel and the reliability of the valves.
The instructions in bold must be followed.