

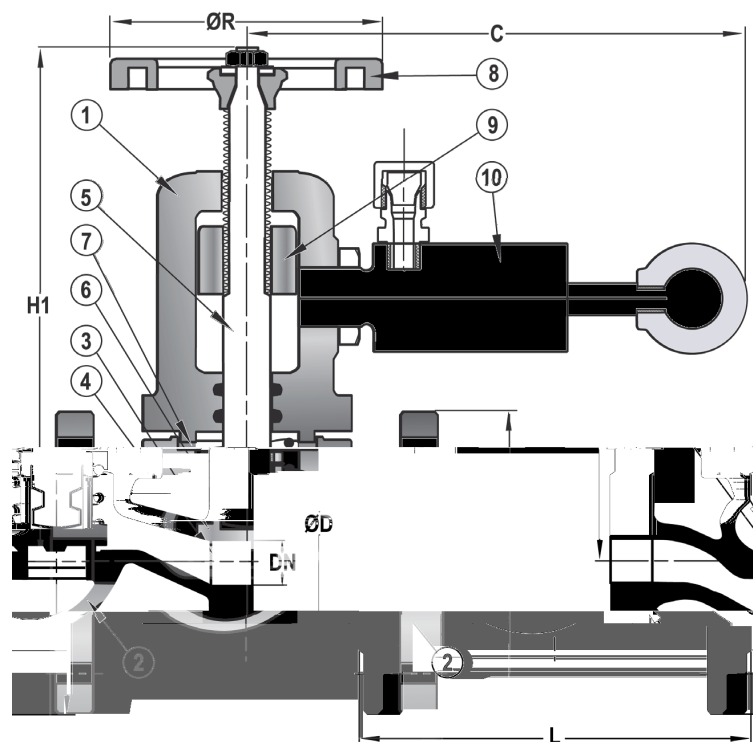

**Quick Closing Valve
PN 16/10 Flange Straight Rg5**

Model/Ref: 567022



*Partnership.
Without Limits.*

www.lauridsenindustri.com

Quick Closing Valve PN 16/10 Flange Straight Rg5

1	Body	Rg5
2	Bonnet	Rg5
3	Disc	AISI 304
4	Seat	AISI 304
5	Stem	AISI 304
6	Spring	1,4310
7	Bonnet gasket	Graphite
8	Handwheel	GG25
9	Retainer block	Brass
10	Cylinder	Brass

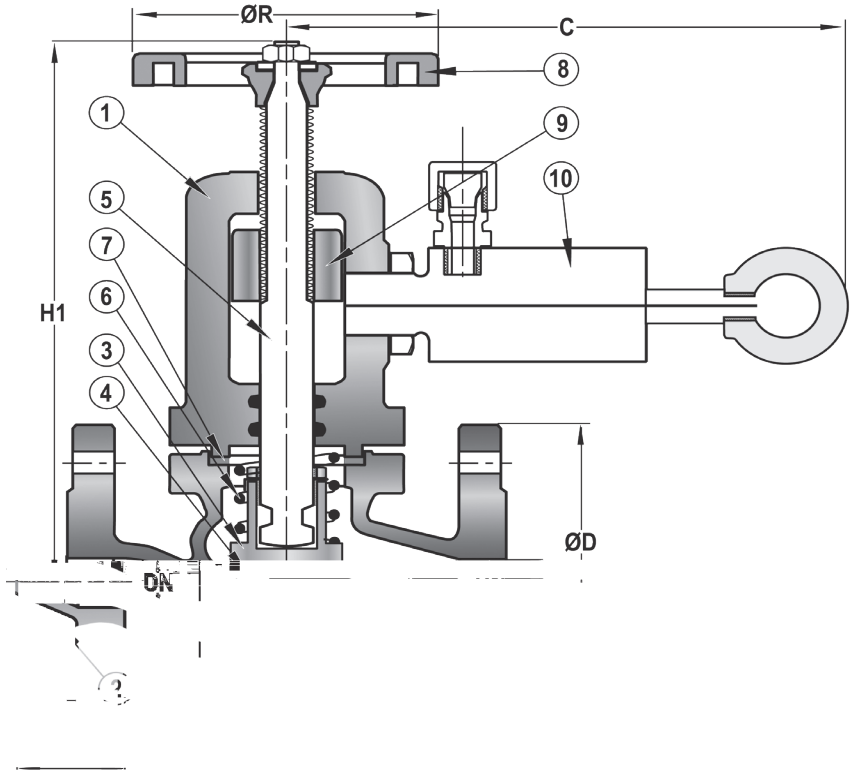

	□					1	□		-	
									150	
15	95	4	65	14	130	175	120	190	1,6	6,0
20	105	4	75	14	150	175	120	190	1,6	7,0
25	115	4	85	14	160	190	140	190	1,6	8,0
32	140	4	100	18	180	190	140	190	1,6	9,0
40	150	4	110	18	200	205	160	195	1,6	13,0
50	165	4	125	18	230	215	160	195	1,6	16,0
65	185	4	145	18	290	245	180	195	1,6	21,0
80	200	8	160	18	310	270	200	195	1,6	28,0
100	220	8	180	18	350	305	225	195	1,6	40,0
125	250	8	210	18	400	330	250	195	1,6	60,0
150	285	8	240	22	480	380	300	195	1,6	115,0
200	340	8	295	22	600	450	400	195	1,0	170,0