

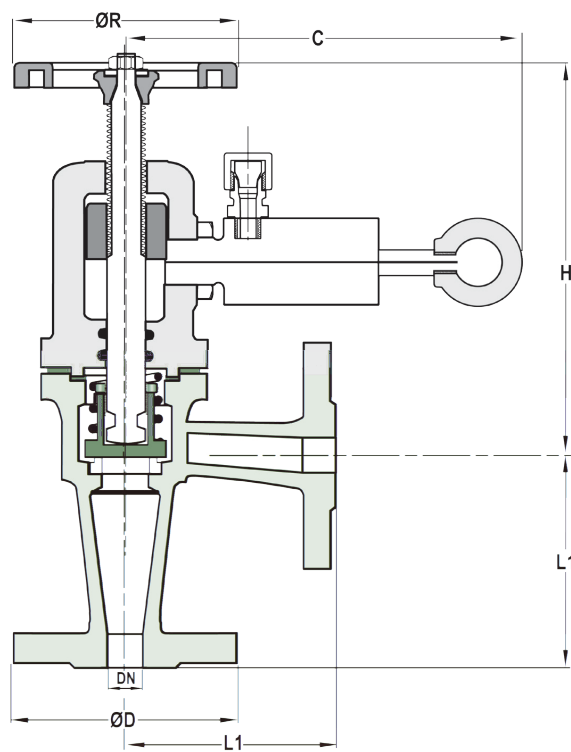

**Quick Closing Valve
PN 16/10 Flange Angle GGG40.3**

Model/Ref: 567102



*Partnership.
Without Limits.*

www.lauridsenindustri.com

Quick Closing Valve PN 16/10 Flange Angle GGG40.3

No	Part	Material
1	Body	GGG40,3
2	Bonnet	GGG40,3
3	Disc	1.4021
4	Seat	1.4301
5	Stem	1.4021
6	Spring	1,4310
7	Bonnet gasket	Graphite
8	Handwheel	GG25
9	Retainer block	Brass
10	Cylinder	Brass

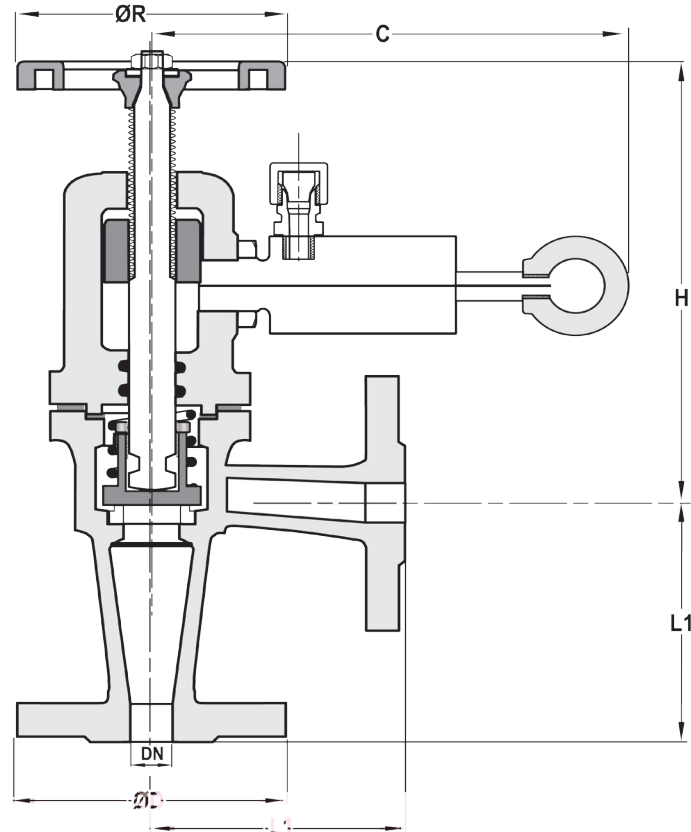
Variants:

Body and Bonnet in steel GS-C25

DN	ØD	L1	H	ØR	C	Max working-pressure		Weight Kg
						Mpa 150 °C	Mpa	
15	95	90	170	120	190	1,6		5,5
20	105	95	170	129	190	1,6		6,5
25	115	100	180	140	190	1,6		7,0
32	140	105	180	140	190	1,6		9,0
40	150	115	200	160	195	1,6		12,0
50	165	125	200	160	195	1,6		15,0
65	185	145	225	180	195	1,6		20,0
80	200	155	245	200	195	1,6		27,0
100	220	175	275	225	195	1,6		36,0
125	250	200	275	250	195	1,6		55,0
150	285	225	315	300	195	1,6		85,0
200	340	275	360	400	195	1,0		120,0