

2 PIECES BALL VALVE PN63 MALE - FEMALE**PRODUCT EVOLUTION**

Be careful, our valves Ref.789 are changing

**We currently have 2 different types available (according to DN)
with different dimensions**

Marking old type :



Marking new Type :



At the end, only the new type will be available (from page 2 to 7)

2 PIECES BALL VALVE PN63 MALE - FEMALE

NEW



ISO 9001 : 2015



TÜVRheinland
PED/97/23/CE

CE

Size : DN 1/4" to 2"
Ends : Male - Female BSP
Min Temperature : - 20°C
Max Temperature : + 180°C
Max Pressure : 63 Bars
Specifications : Anti blow-out stem
Locking device
Full bore

Materials : Stainless steel ASTM A351 CF8M

2 PIECES BALL VALVE PN63 MALE - FEMALE
SPECIFICATIONS :

- Full bore
- Anti blow-out stem
- PTFE packing
- Locking device
- Solid ball
- 2 pieces type

USE :

- Chemical and pharmaceutical industries, petrochemical industries, hydraulic installation, compressed air
- Min and max Temperature Ts : -20°C to + 180°C
- Max Pressure Ps : 63 bars up to DN3/4", 50 bars DN 1" to 1"1/4 and 40 bars DN 1"1/2 to 2" (see graph)

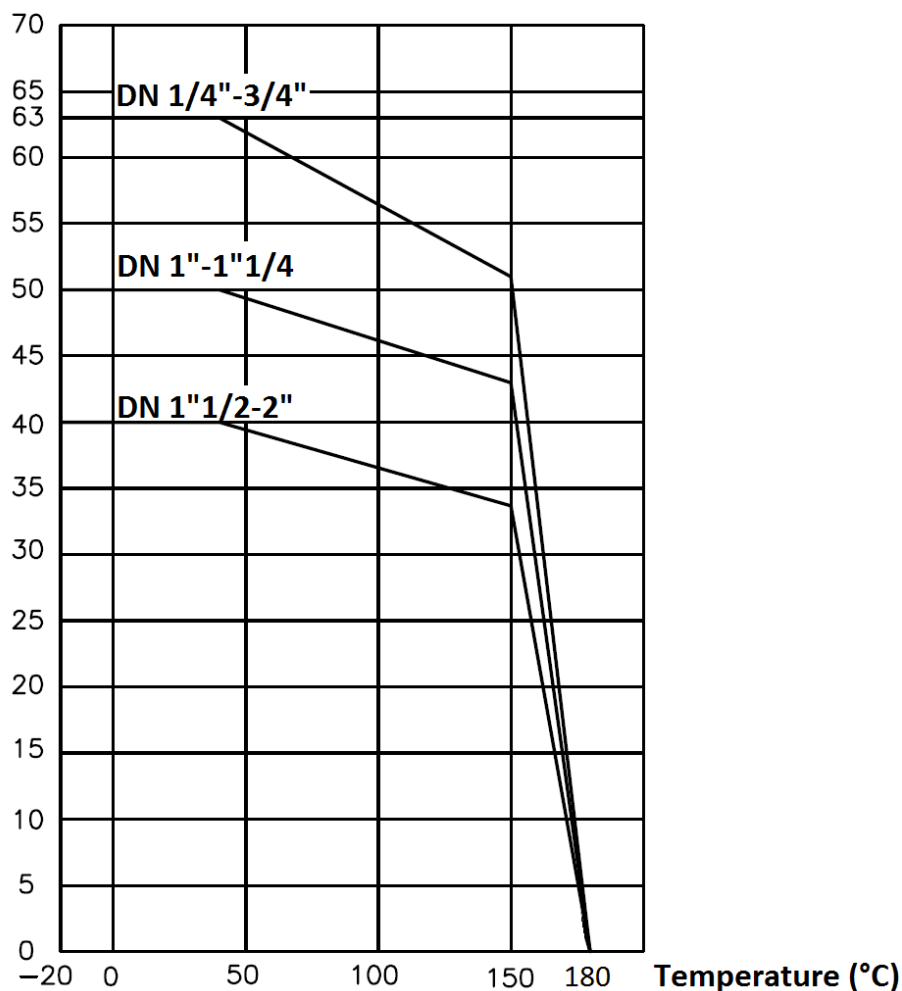
PRESSURE / TEMPERATURE GRAPH (STEAM EXCLUDED) :
PRESSURE (Bar)

2 PIECES BALL VALVE PN63 MALE - FEMALE

RANGE :

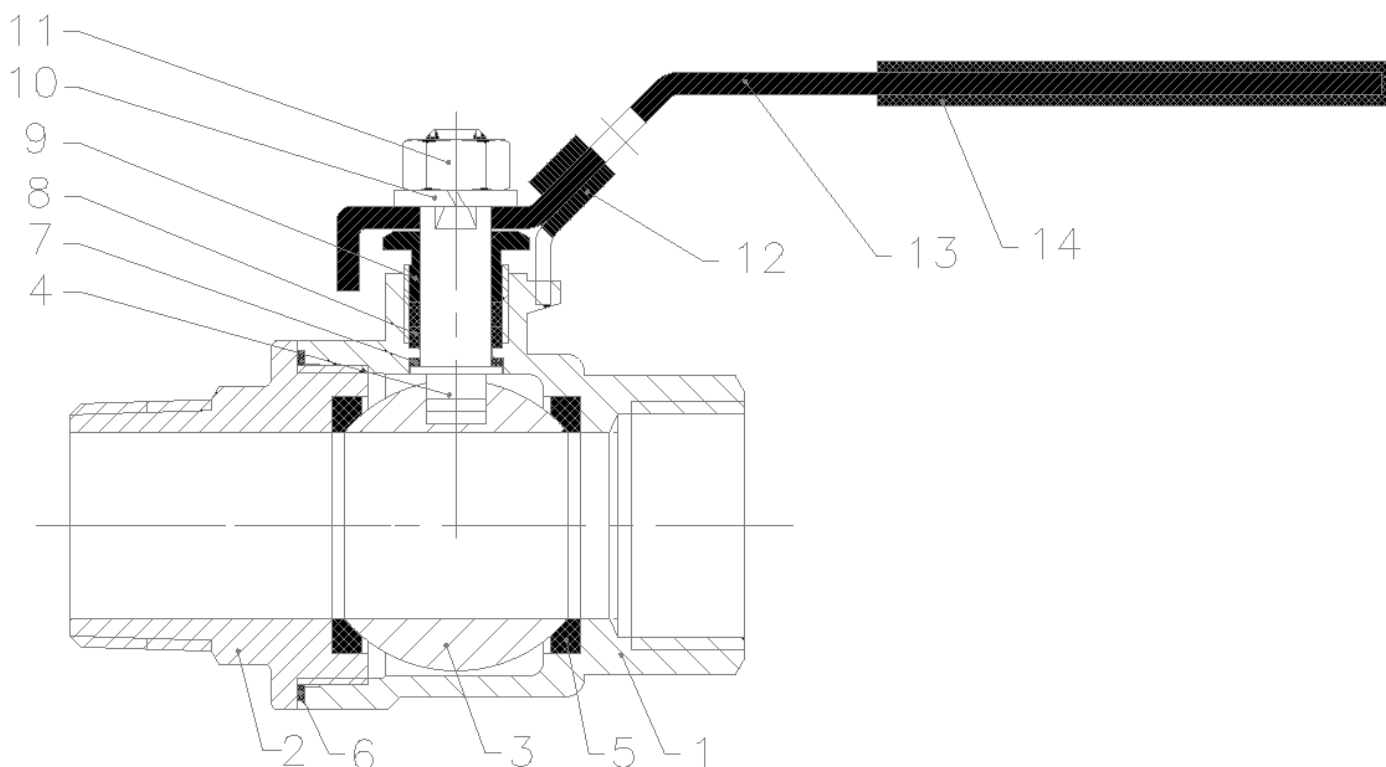

- Stainless steel Male / female cylindrical BSP threaded with red flat steel handle DN 1/4" to DN 2" **Ref.789**
- Butterfly handle **Ref. 9831441 to 9831443** from DN 1/4" to DN 1"

2 PIECES BALL VALVE PN63 MALE - FEMALE
MATERIALS :

Item	Designation	Materials
1	Body	ASTM A351 CF8M
2	Bonnet	
3	Ball	AISI 316
4	Stem	PTFE filled with 3% glass
5	Seat	
6	Gasket	PTFE
7	Stem gasket	
8	Packing	AISI 304
9	Packing nut	
10	Washer	
11	Handle nut	
12	Locking device	Plastic
13	Handle	
14	Handle cover	

2 PIECES BALL VALVE PN63 MALE - FEMALE

SIZE (in mm) :

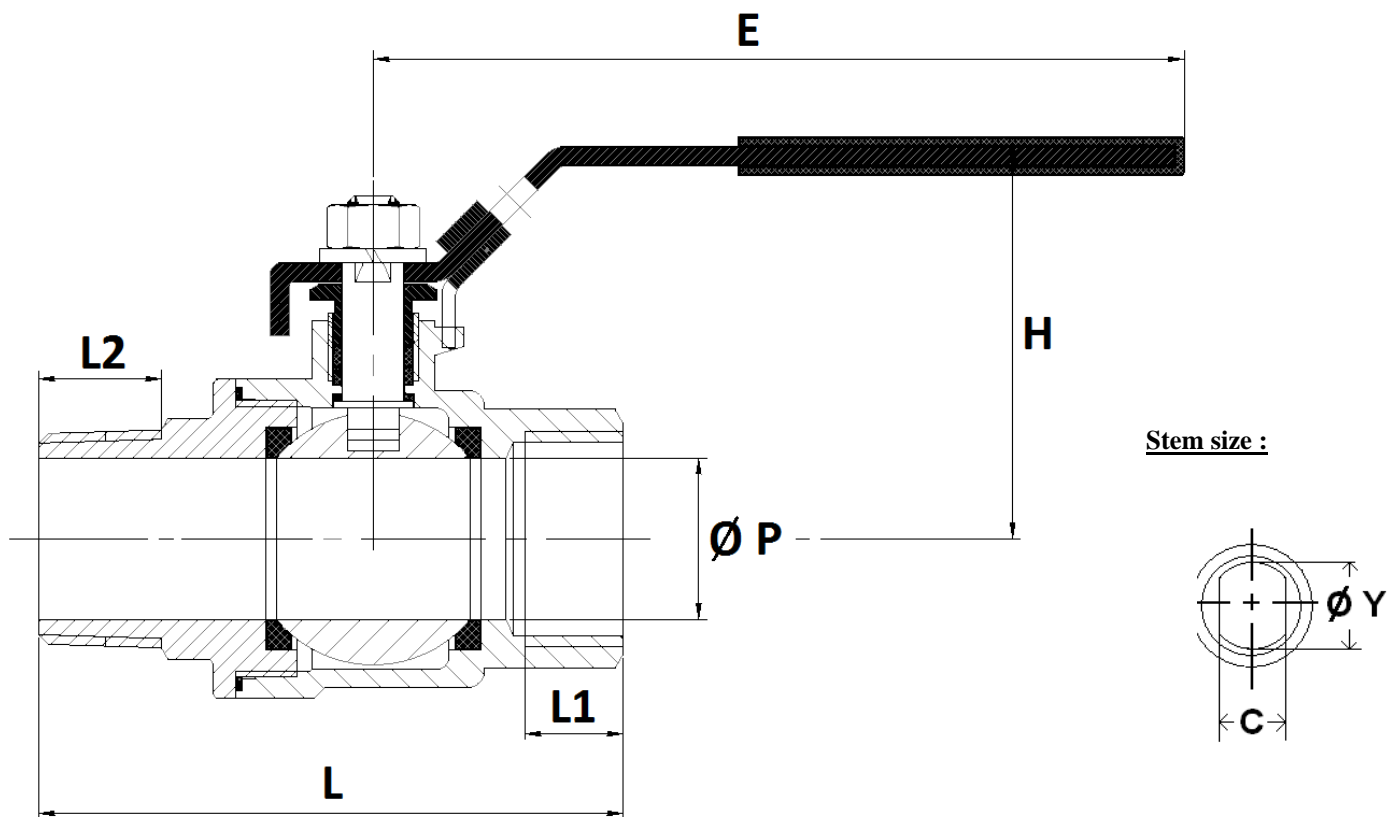

Ref.	DN	1/4"	3/8"	1/2"	3/4"	1"	1"1/4"	1"1/2"	2"
789	Ø P	10.8	11.6	15	20	25	32	38	50
	L	56.5	58.2	69	77.7	90.5	105.5	114.2	139.5
	E	103	103	103	126	126	154	154	192
	H	43.5	43.5	49	59.4	63	80	84	94
	L1	10.5	10.5	13	13.2	15.2	18	18.3	22.5
	L2	11	11.4	15	16.5	19	21.5	21.5	26
	C	5	5	5	5.8	5.8	7	7	8
	Ø Y	8	8	8	9.2	9.2	11	11	12.4
	Weight (Kg)	0.18	0.19	0.26	0.42	0.63	1.07	1.48	2.60

2 PIECES BALL VALVE PN63 MALE - FEMALE

TORQUE VALUES (in Nm without safety coefficient) :

DN	1/4"	3/8"	1/2"	3/4"	1"	1"1/4"	1"1/2"	2"
Torque (Nm)	4	4	6	10	14	20	25	35

STANDARDS :

- Fabrication according to ISO 9001 : 2015
- DIRECTIVE 97/23/CE : CE N° 0035
Risk Category II Module D1
- Pressure tests according to ISO 5208, Rate A
- Threaded female BSP cylindrical ends according to ISO 228-1 and male BSP conical according to ISO 7-1 R

ADVICE : Our opinion and our advice are not guaranteed and SFERACO shall not be liable for the consequences of damages. The customer must check the right choice of the products with the real service conditions.

INSTALLATION AND MAINTENANCE

BEFORE INSTALLATION :

Pipe-line must be cleaned and free from residual of weldings, rubbish, shaving and every kind of extraneous materials. Pipe-line must be perfectly aligned and their support properly dimensioned so that there's no external constraint.

Please use the right product according to the services conditions to seal the valve. Use the right bolt tightening so that the ends won't be damaged.

CLEANING AND TESTS

Keep closed the valves during the cleaning operation so that there's no impurities between the ball and the body.

Tests under pressure must be done with a cleaned pipe-line.

Open partially the valve for tests. Pressure test do not exceed the valve specifications according to ISO 5208.

MAINTENANCE

It's recommended to operate the valve twice (open and close) 1 to 2 times per year.

When intervention on the valve, be sure there's no pressure in the pipe-line, there's no fluid in it, and that it is isolated. The temperature must be low enough to operate without risks. If there's a corrosive fluid, inert installation before intervention.

When the valve is under pressure :

If there's a leakage at the packing, tighten it slightly so that the leakage disappears.

2 PIECES BALL VALVE PN63 MALE - FEMALE



Size : DN 1“1/4
Ends : Male - Female BSP
Min Temperature : - 20°C
Max Temperature : + 180°C
Max Pressure : 63 Bars
Specifications : Anti blow-out stem
Locking device
Reduced bore

Materials : Stainless steel ASTM A351 CF8M

2 PIECES BALL VALVE PN63 MALE - FEMALE

SPECIFICATIONS :

- Reduced bore
- Anti blow-out stem
- PTFE packing
- Locking device
- Solid ball
- 2 pieces type

USE :

- Chemical and pharmaceutical industries, petrochemical industries, hydraulic installation, compressed air
- Min and max Temperature Ts : -20°C to + 180°C
- Max Pressure Ps : 50 bars from DN 1" to 1"1/4 (see graph)

PRESSURE / TEMPERATURE GRAPH (STEAM EXCLUDED) :

PRESSURE

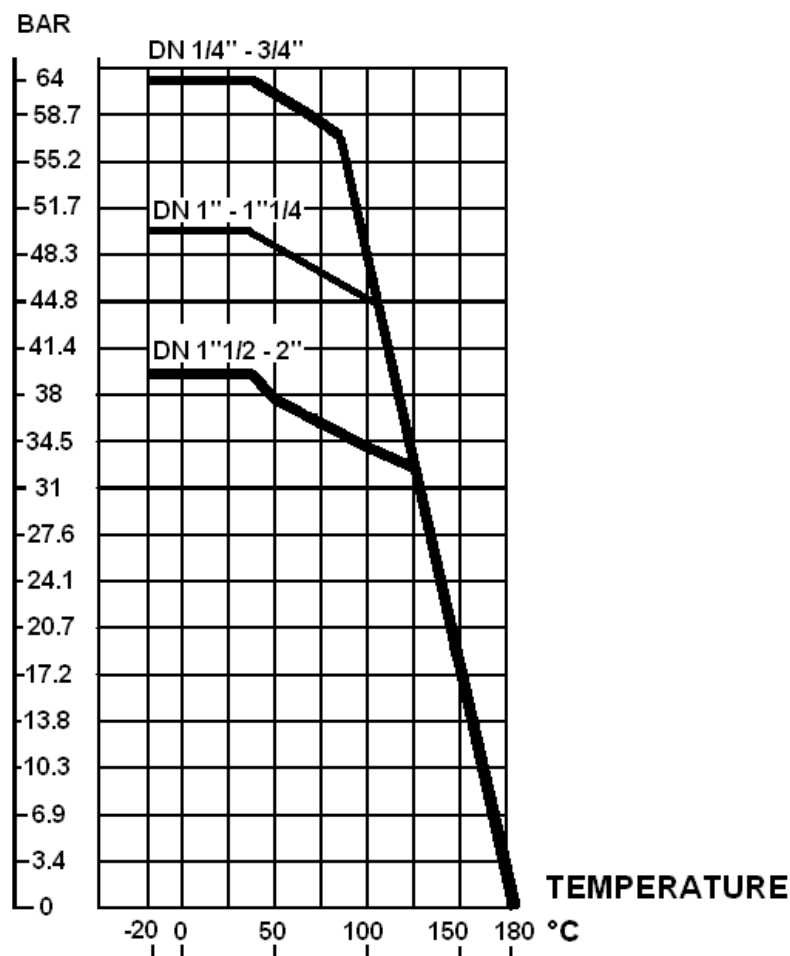

2 PIECES BALL VALVE PN63 MALE - FEMALE

RANGE :



- Stainless steel Male / female cylindrical BSP threaded with red flat steel handle DN 1"1/4

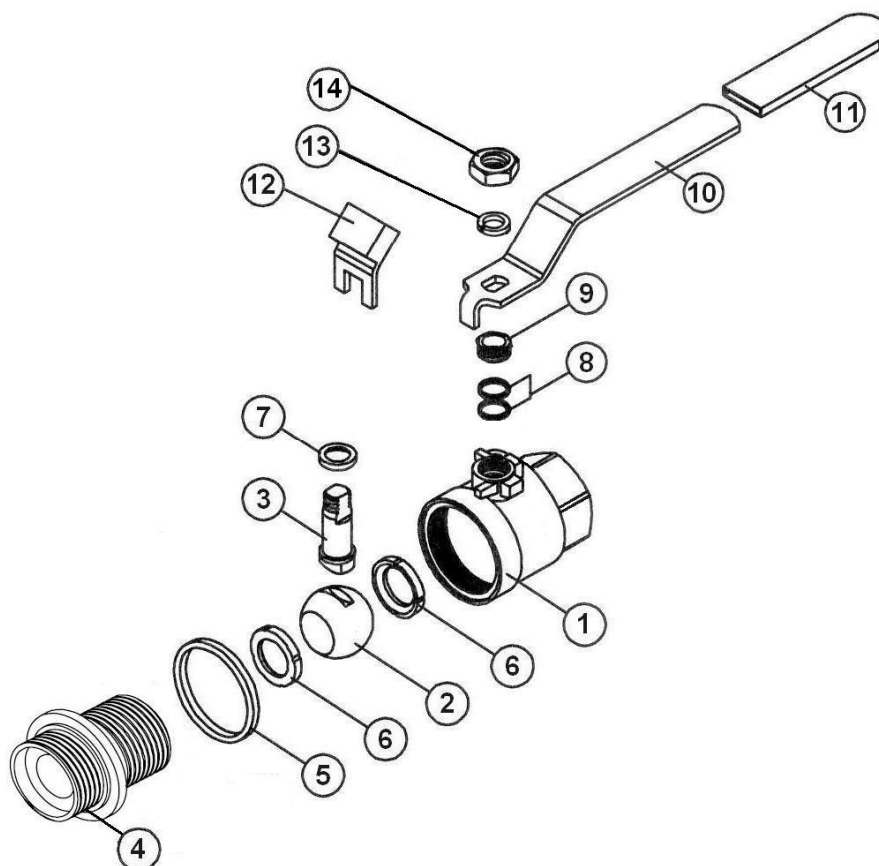

- Blue handle cover **Ref. 9830380 to 9830383** from DN 1/4" to DN 2"

2 PIECES BALL VALVE PN63 MALE - FEMALE
MATERIALS :

Item	Designation	Materials
1	Body	ASTM A351 CF8M
2	Ball	ASTM A351 CF8M
3	Stem	SS 316
4	Bonnet	ASTM A351 CF8M
5	Body seal	PTFE
6	Seat	PTFE filled with 15% glass
7	Stem gasket	PTFE
8	Packing	PTFE
9	Packing nut	SS 304
10	Handle	SS 304
11	Handle cover	Plastic
12	Locking device	SS 304
13	Washer	SS 304
14	Handle nut	SS 304

2 PIECES BALL VALVE PN63 MALE - FEMALE

SIZE (in mm) :

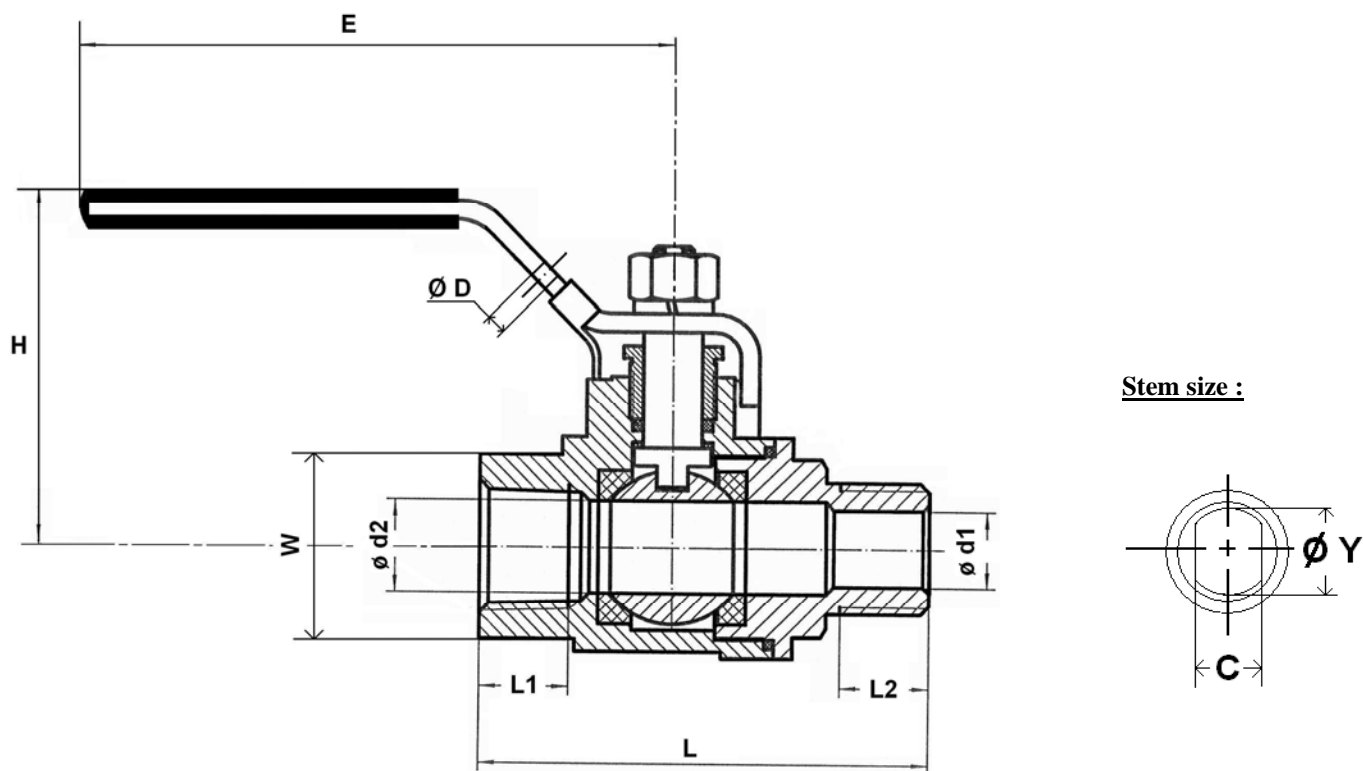

Stem size :

Ref.	DN	1"1/4
789	Ø d1	30.8
	Ø d2	32
	L	112
	Ø D	8
	E	148
	H	78
	L1	19
	L2	21.5
	W on flat	48
	C	8
	Ø Y	9
	Weight (Kg)	1.32

2 PIECES BALL VALVE PN63 MALE - FEMALE

TORQUE VALUES (in Nm without safety coefficient) :

DN	1/4"	3/8"	1/2"	3/4"	1"	1"1/4	1"1/2	2"
TORQUE (Nm)	2.7	2.7	3	4	5	6	8	10

STANDARDS :

- Fabrication according to ISO 9001 : 2008
- DIRECTIVE 97/23/CE : CE N° 0035
Risk Category III Module H
- Pressure tests according to ISO 5208, rate A
- Threaded male and female BSP cylindrical ends according to ISO 228-1

ADVICE : Our opinion and our advice are not guaranteed and SFERACO shall not be liable for the consequences of damages. The customer must check the right choice of the products with the real service conditions.

INSTALLATION AND MAINTENANCE

BEFORE INSTALLATION :

Pipe-line must be cleaned and free from residual of weldings, rubbish, shaving and every kind of extraneous materials. Pipe-line must be perfectly aligned and their support properly dimensioned so that there's no external constraint.

Please use the right product according to the services conditions to seal the valve.
Use the right bolt tightening so that the ends won't be damaged.

CLEANING AND TESTS

Keep closed the valves during the cleaning operation so that there's no impurities between the ball and the body.

Tests under pressure must be done with a cleaned pipe-line.

Open partially the valve for tests. Pressure test do not exceed the valve specifications according to EN 12266-1.

MAINTENANCE

It's recommended to operate the valve twice (open and close) 1 to 2 times per year.

When intervention on the valve, be sure there's no pressure in the pipe-line, there's no fluid in it, and that it is isolated. The temperature must be low enough to operate without risks.
If there's a corrosive fluid, inert installation before intervention.

When the valve is under pressure :

If there's a leakage at the packing, tighten it slightly so that the leakage disappears.