



## WAFER BUTTERFLY VALVE PN10/16

Model/Ref: 1123



*Partnership.  
Without Limits.*

[www.lauridsenindustri.dk](http://www.lauridsenindustri.dk)

**WAFER BUTTERFLY VALVE PN10/16**

ISO 9001  
BUREAU VERITAS  
Certification



**Size :** DN 32/40 to DN 1200  
**Ends :** Between flanges PN10/16, ANSI150 up to DN600  
**Min Temperature :** -10°C  
**Max Temperature :** + 110°C ( 130°C temporarily )  
**Max Pressure :** 16 Bars up to DN300  
**Specifications :** Long neck for isolation  
Stainless steel disc  
Vulcanised EPDM seat

**Materials :** Cast iron body

WAFER BUTTERFLY VALVE PN10/16

**SPECIFICATIONS :**

- Long neck for isolation
- ISO 5211 mounting pad
- Wafer type
- Between flanges ISO PN10/16 from DN32 to DN600 and ISO PN20 ANSI150 from DN 40 to DN 600
- Between flanges ISO PN10 from DN 700 to DN1200
- Full crossing stem up to DN600
- With 10 positions lever and locking device up to DN150
- Double PTFE seal on stem up to DN600
- Stainless steel disc
- Epoxy painting RAL003 80 microns thickness
- Vulcanised EPDM seat

**USE :**

- Cold and hot water, sea water, demineralized water, alcohol, milk of lime, mercury, alcalins, hydroxid of soda
- Min and max Temperature Ts : - 10°C to + 110°C ( 130°C temporarily )
- Max Pressure Ps : 16 bars up to DN300 , 10 bars over

**FLOW COEFFICIENT Kv ( M3 / h ) :**

DN		32/40	50	65	80	100	125	150	200	250	300	350	400	450	500	600
Opening angle	10°	0,04	0,05	0,09	0,17	0,26	0,43	0,68	1,7	2,6	3,4	5,1	6,8	9,4	11,9	18,8
	20°	2	3	5	8	15	25	38	76	129	200	288	396	525	675	1042
	30°	5	6	10	15	31	52	81	160	273	422	610	839	1101	1428	2207
	40°	10	13	21	33	67	113	175	348	592	914	1321	1817	2407	3095	4781
	50°	18	23	38	60	119	202	312	620	1055	1630	2355	3239	4289	5515	8521
	60°	30	38	64	99	196	334	516	1025	1746	2697	3897	5359	7097	9125	14098
	70°	48	60	102	156	310	529	817	1623	2764	4269	6167	8481	11232	14442	22312
	80°	72	90	152	235	466	793	1226	2434	4145	6403	9250	12720	16848	21662	33468
	90°	78	98	167	258	512	872	1347	2675	4555	7037	10165	13799	18514	23805	36778

DN		700	800	900	1000	1200
Opening angle	10°	31	39	52	72	104
	20°	1568	2064	2612	3617	5172
	30°	3147	4143	5243	7260	10379
	40°	5739	7555	9561	13238	18932
	50°	8648	11925	15091	20894	29879
	60°	12929	17827	22561	31279	44730
	70°	19692	27153	34362	47641	68126
	80°	30182	41615	52667	73017	104415
	90°	42811	59028	74406	103569	148105

**WAFER BUTTERFLY VALVE PN10/16**

**TORQUE VALUE ( Nm, without safety coefficient ) :**

We recommend a safety coefficient of 30% minimum to determinate the actuator.

DN	32/40	50	65	80	100	125	150	200	250	300	350	400	450	500	600	700	800	900	1000	1200
PN10	11	15	24	31	48	73	106	177	281	410	475	746	1112	1356	2468	4908	6462	7886	13389	18833
PN16	12	16	26	33	53	81	119	194	308	441	-	-	-	-	-	-	-	-	-	-

**RANGE :**

- With lever from DN32/40 to DN300
- With gear box from DN350 to DN1200
- Gear box possible from DN32/40 to DN300 **Ref.1198**

**WAFER BUTTERFLY VALVE PN10/16**

MATERIALS DN 32/40 – 300 :

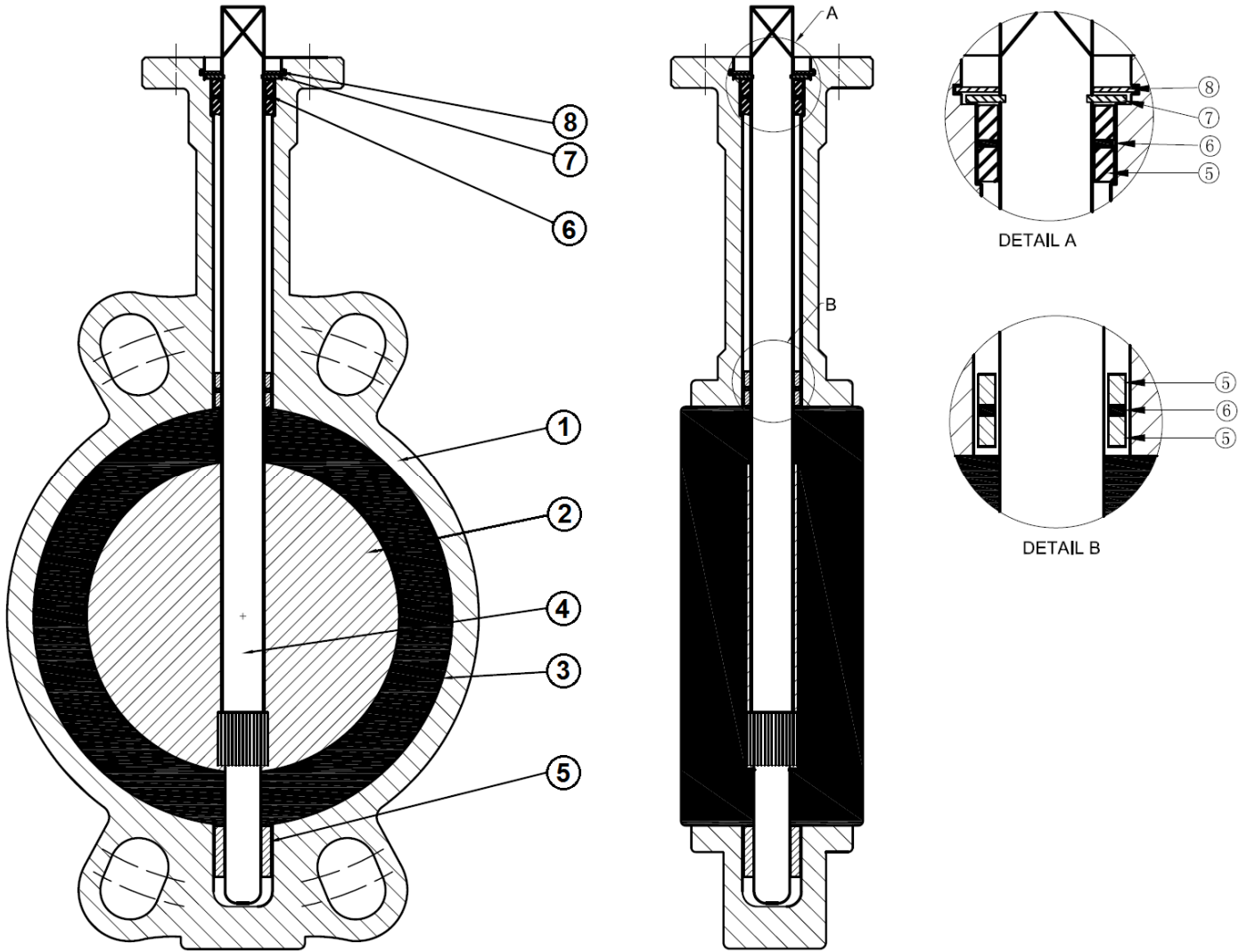

Item	Designation	Materials
1	Body	Cast iron EN GJL-250
2	Disc	ASTM A351 CF8M
3	Elastic ring	EPDM
4	Stem	SS 416
5	Bushing	PTFE
6	O ring	EPDM
7	Circlip	Steel
8	Circlip	Steel
	Lever	Aluminium

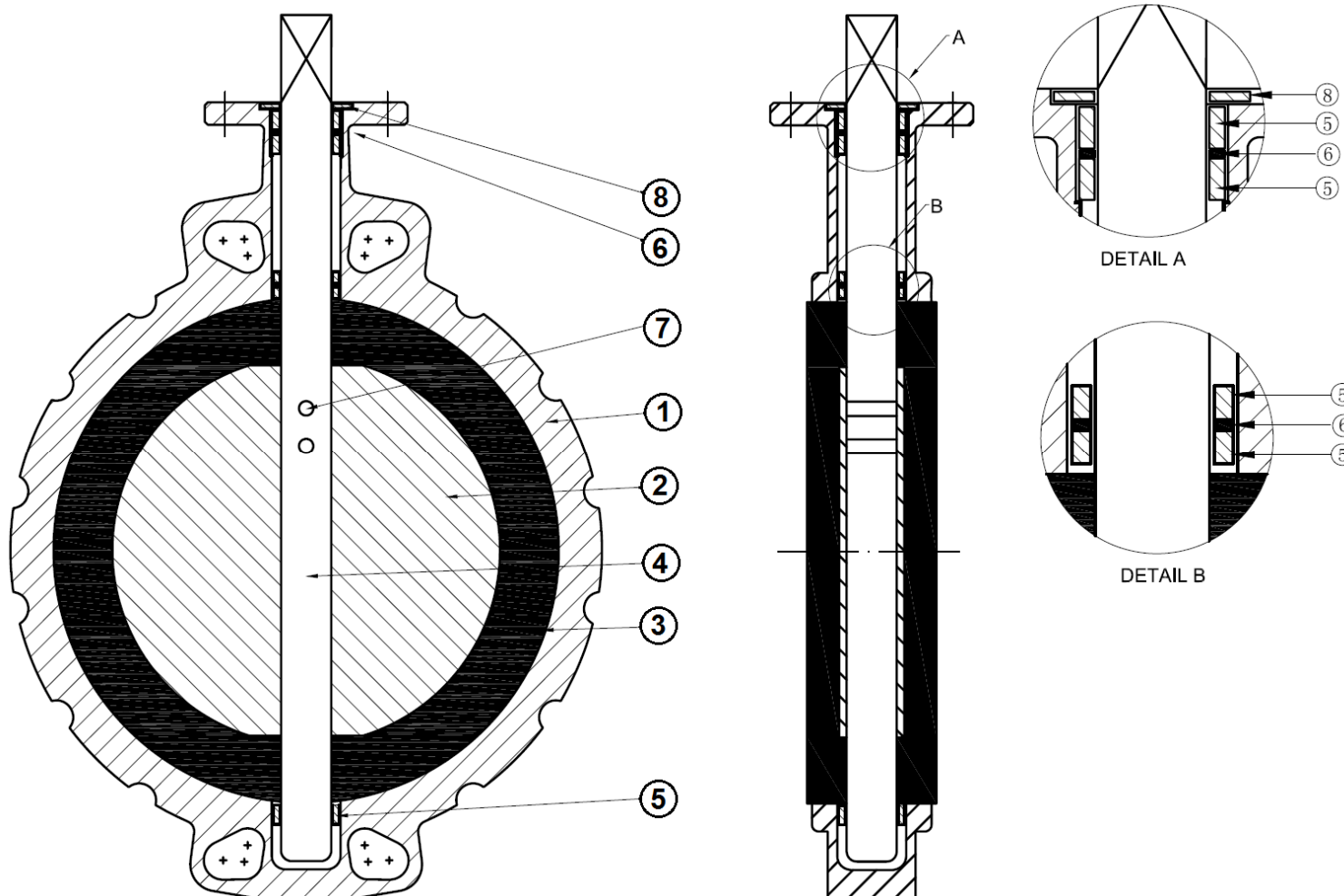
**WAFER BUTTERFLY VALVE PN10/16**
**MATERIALS DN 350 :**

Item	Designation	Materials
1	Body	Cast iron EN GJL-250
2	Disc	ASTM A351 CF8M
3	Elastic ring	EPDM
4	Stem	SS 431
5	Bushing	PTFE
6	O ring	EPDM
7	Pin	SS 316
8	Gasket	EPDM

WAFER BUTTERFLY VALVE PN10/16

MATERIALS DN 400-600 :

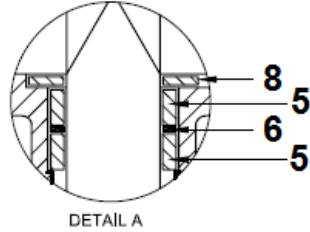

DETAIL A

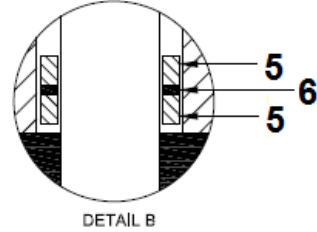

DETAIL B

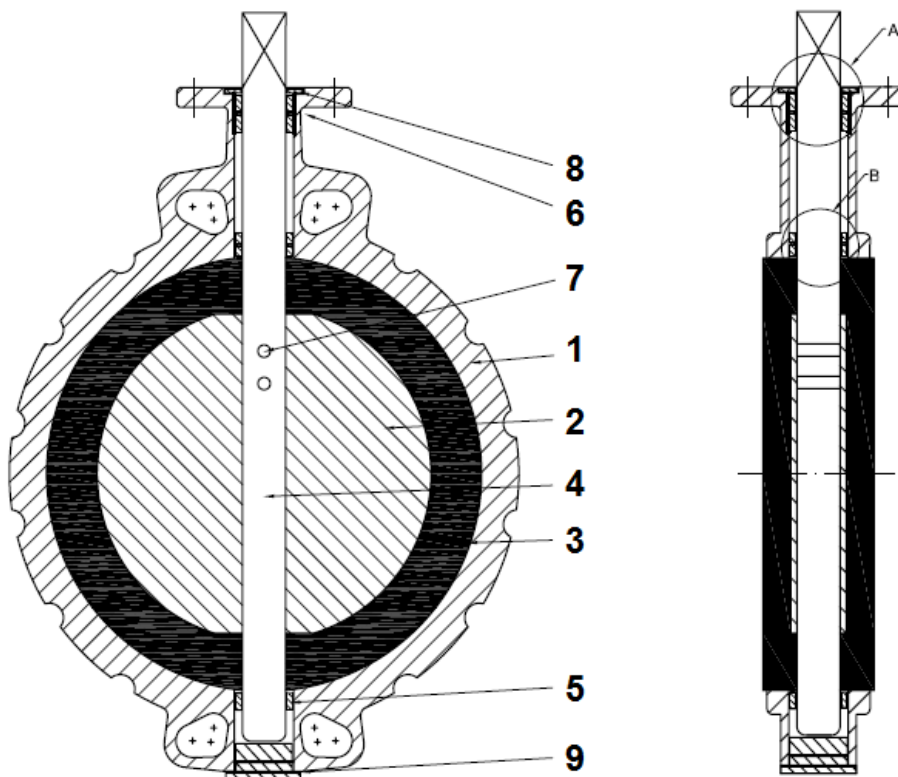

Item	Designation	Materials
1	Body	Cast iron EN GJL-250
2	Disc	ASTM A351 CF8M
3	Elastic ring	EPDM
4	Stem	SS 431
5	Bushing	PTFE
6	O ring	EPDM
7	Pin	SS 316
8	Gasket	EPDM
9	Gasket	EPDM



**WAFER BUTTERFLY VALVE PN10/16**

MATERIALS DN 700 – 1200 :

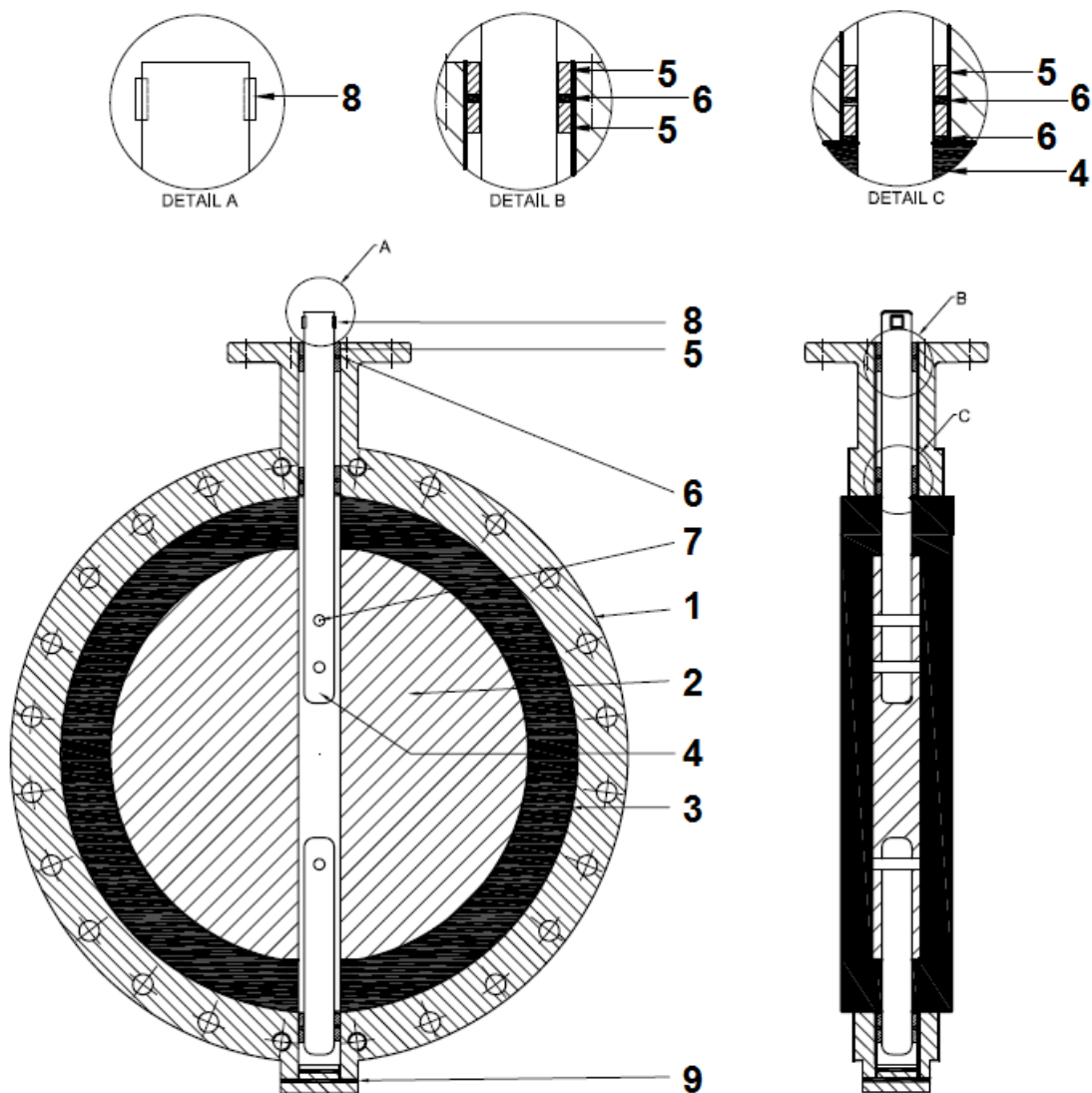

Item	Designation	Materials
1	Body	Cast iron EN GJL-250
2	Disc	ASTM A351 CF8M
3	Elastic ring	EPDM
4	Stem	SS 431
5	Bushing	Aluminium + Bronze
6	O ring	EPDM
7	Pin	SS 316
8	Pin	SQ 719
9	Gasket	EPDM

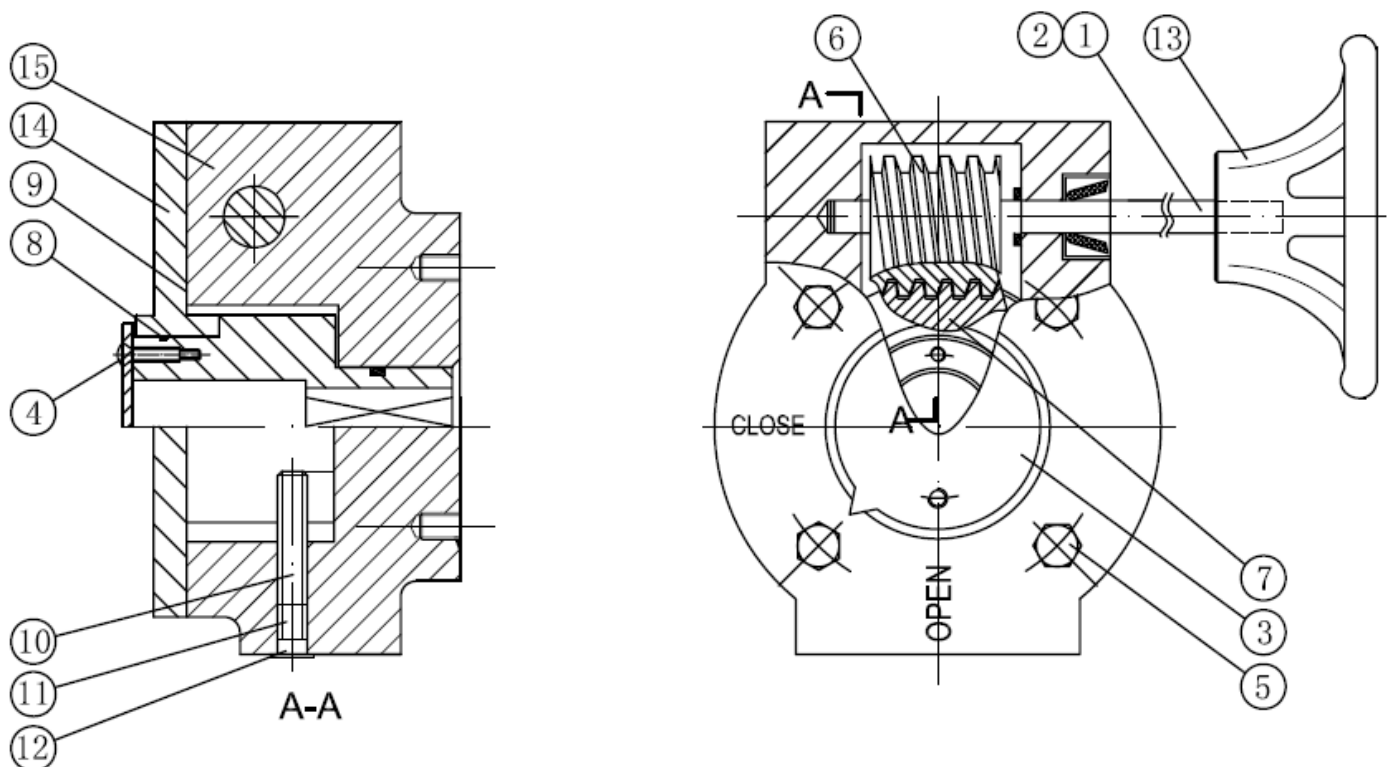

**WAFER BUTTERFLY VALVE PN10/16**
**MATERIALS GEARBOX DN40-450 :**

Item	Designation	Materials
1	Stem	Chromed steel
2	Pin	SS 316
3	Indicator plate	Aluminium + NBR gasket
4	Indicator bolt, washer	SS 316
5	Bolt, washer	SS 316
6	Gear 1	Steel
7	Gear 2	Ductile iron EN GJS-400-15
8	O ring	NBR
9	Bonnet gasket	NBR
10	Internal set screw	Carbon steel
11	External set screw	SS 316
12	Plastic cap	Plastic
13	Handwheel	Cast iron EN GJL-250 epoxy coating
14	Bonnet	Cast iron EN GJL-250 epoxy coating
15	Body	Cast iron EN GJL-250 epoxy coating
	Bolting to fix on valve	SS 304

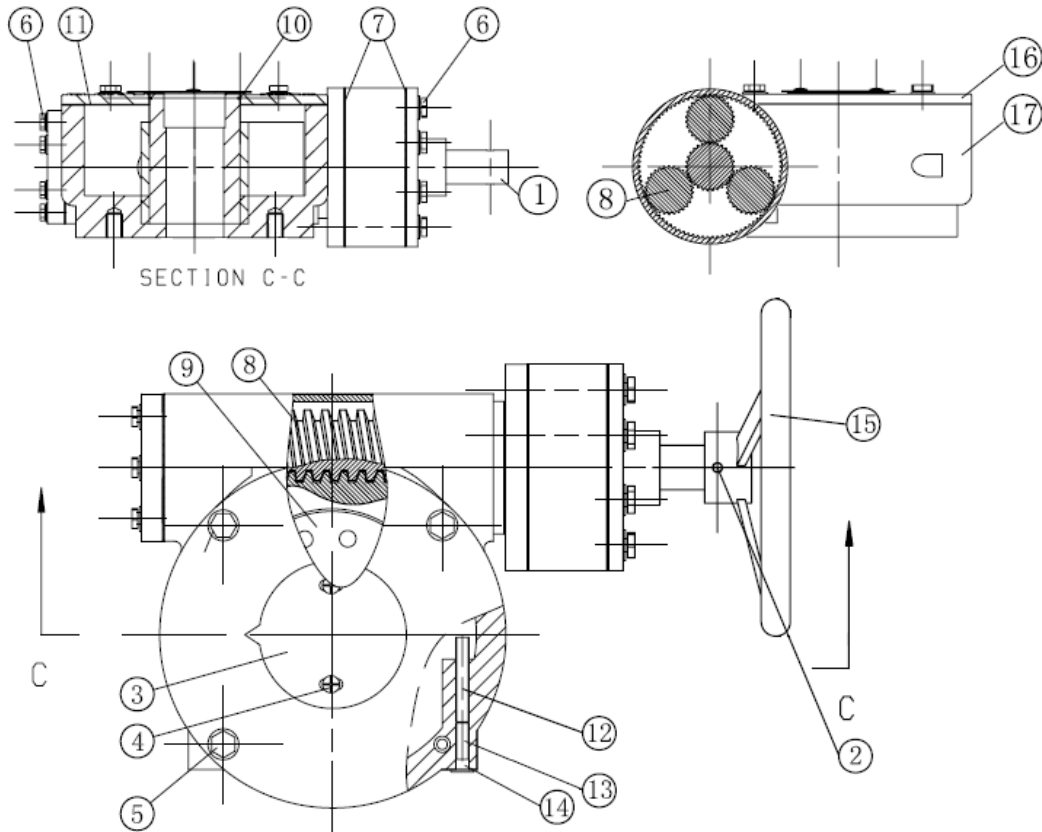
**WAFER BUTTERFLY VALVE PN10/16**
**MATERIALS GEARBOX DN500-600 :**

Item	Designation	Materials
1	Stem	Chromed steel
2	Pin	SS 316
3	Indicator plate	Aluminium + NBR
4	Indicator bolt, washer	SS 316
5	Bolt, washer	SS 316
6	Bolting	SS 316
7	Body gasket	NBR
8	Gear 1	Steel
9	Gear 2	Ductile iron EN GJS-400-15
10	O ring	NBR
11	Bonnet gasket	NBR
12	Internal set screw	Acier
13	External set screw	SS 316
14	Cap	Plastic
15	Handwheel	Cast iron EN GJL-250 epoxy coating
16	Bonnet	Cast iron EN GJL-250 epoxy coating
17	Body	Cast iron EN GJL-250 epoxy coating
	Bolting to fix on valve	SS 304

## WAFER BUTTERFLY VALVE PN10/16

**MATERIALS GEARBOX DN700-1200 :**

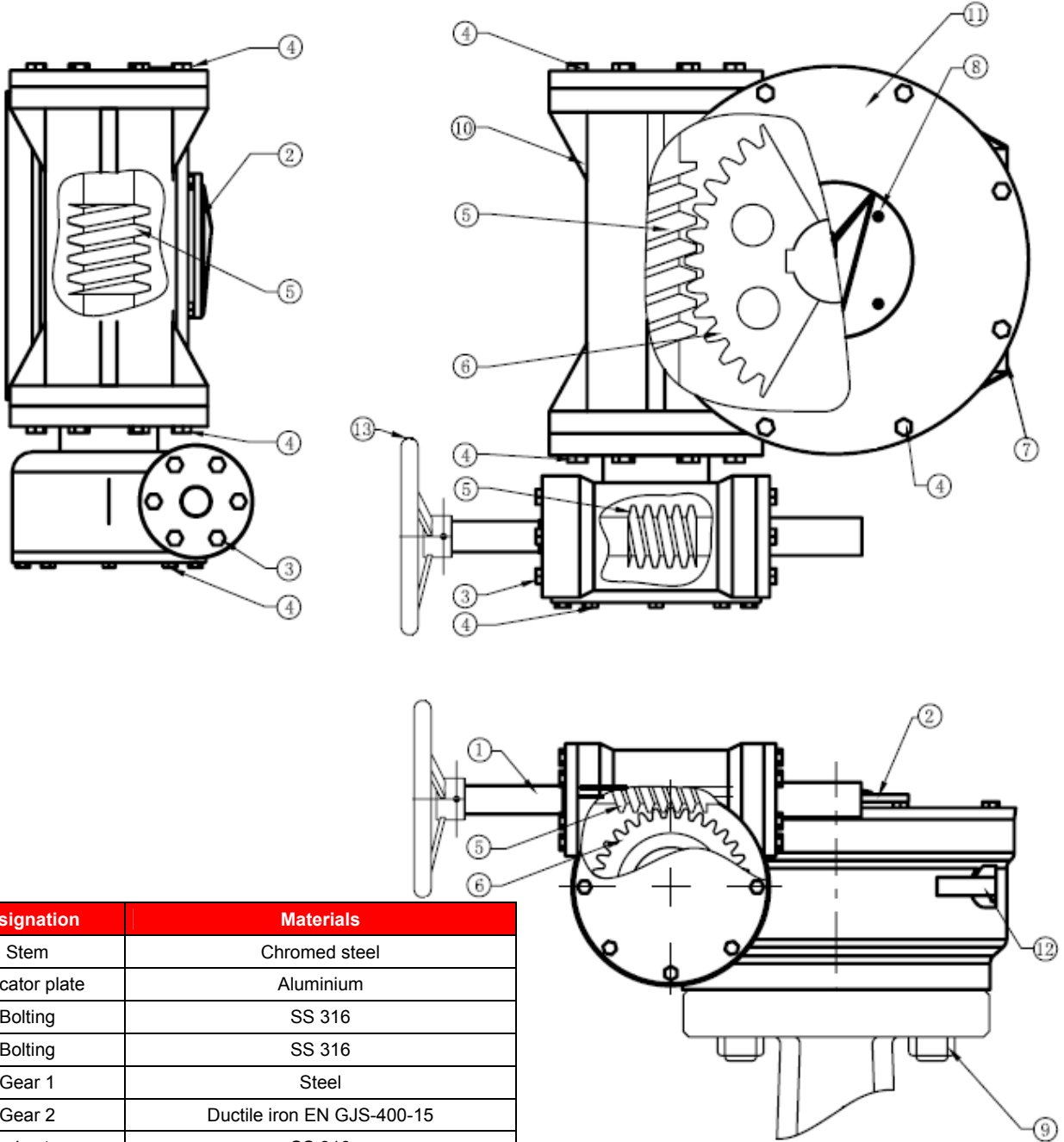

Item	Designation	Materials
1	Stem	Chromed steel
2	Indicator plate	Aluminium
3	Bolting	SS 316
4	Bolting	SS 316
5	Gear 1	Steel
6	Gear 2	Ductile iron EN GJS-400-15
7	External set screw	SS 316
8	Screw	SS 316
9	Bolting	SS 304
10	Body	Cast iron EN GJL-250 epoxy coating
11	Bonnet	Cast iron EN GJL-250 epoxy coating
12	Internal set screw	Steel
13	Handwheel	Ductile iron EN GJS-400-15 epoxy coating

**WAFFER BUTTERFLY VALVE PN10/16**

VALVES SIZE ( in mm ) :

- VALVES WITH LEVER DN 32/40 - 300 :

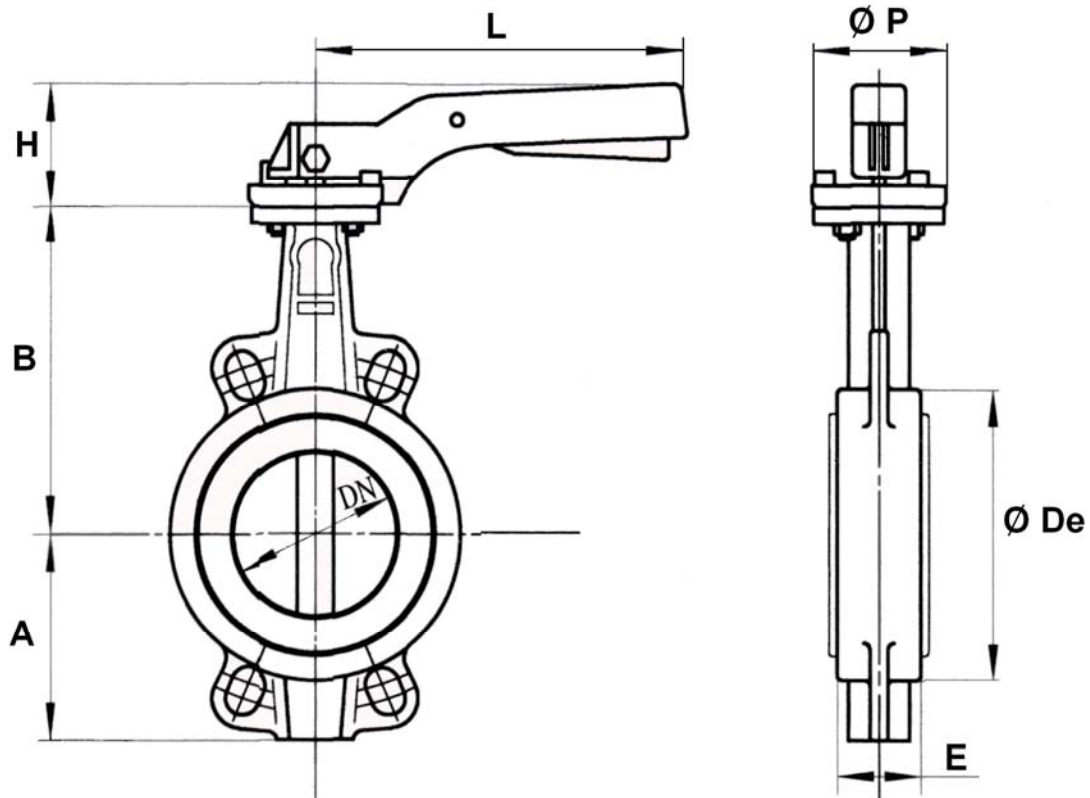

Ref.	DN	32/40	50	65	80	100	125	150	200	250	300
1123	A	61	77	87,5	95	107	121,5	144	171	205	235
	B	130	136,5	142	158	180	192	215	242	280	310
	Ø De	82	95	109	127	152	180	207	260	315	370
	E	33	43	46	46	52	56	56	60	68	78
	H	70	70	70	70	70	71	71	40	44	44
	L	195	195	195	195	195	278	278	355	507	507
	Ø P	65	65	65	65	65	90	90	125	150	150
	Weig. (Kg)	1.85	2.53	2.86	3.16	4.21	6.67	7.66	14.67	23.4	33.8

## WAFER BUTTERFLY VALVE PN10/16

VALVES SIZE ( in mm ) :

- VALVES WITH GEAR BOX DN 350 :

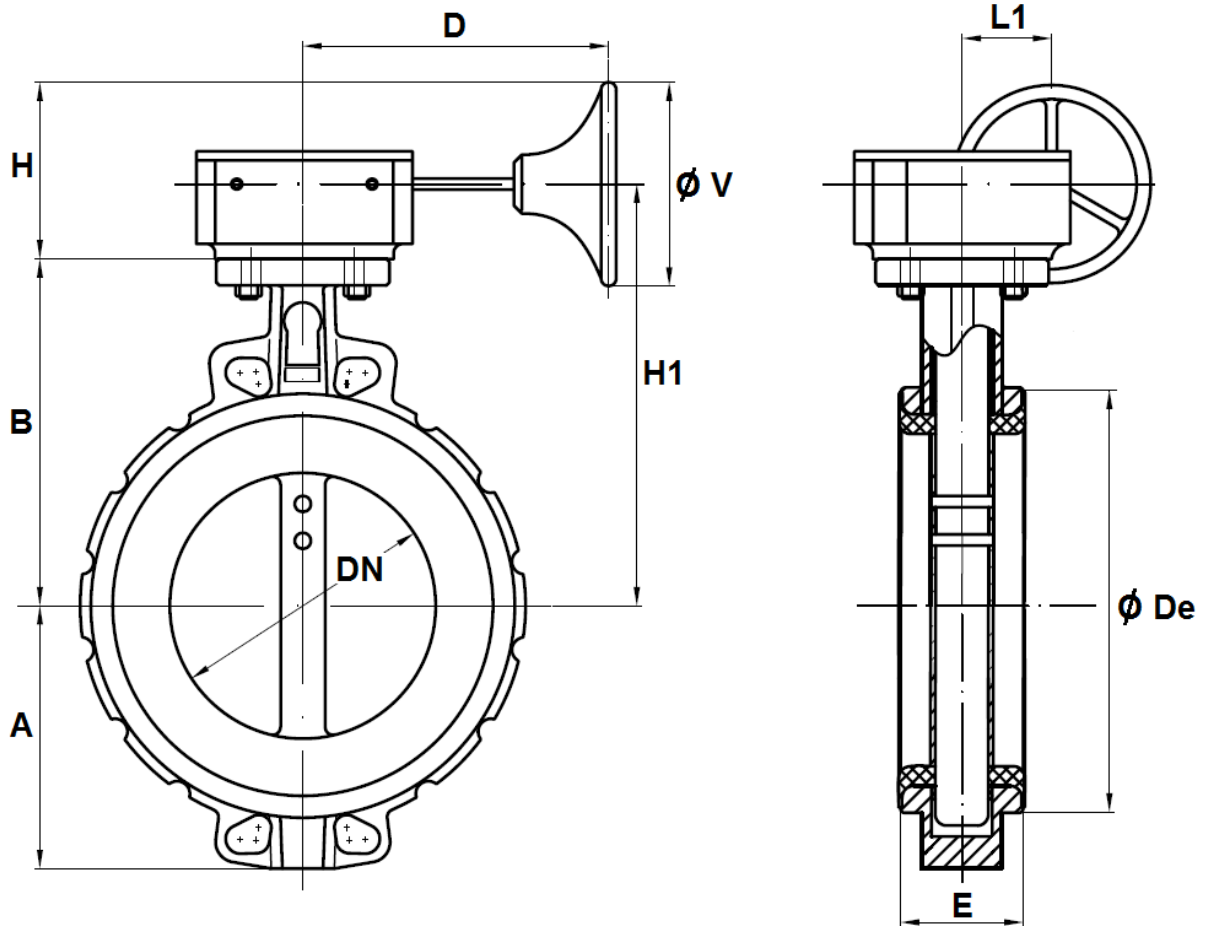

Ref.	DN	350
1123	A	260
	B	334
	D	223
	Ø De	418
	E	78
	H	190
	H1	379
	L1	78
	Ø V	300
	Weight (Kg)	54.5

**WAFER BUTTERFLY VALVE PN10/16**

VALVES SIZE ( in mm ) :

- VALVES WITH GEAR BOX DN 400-600 :

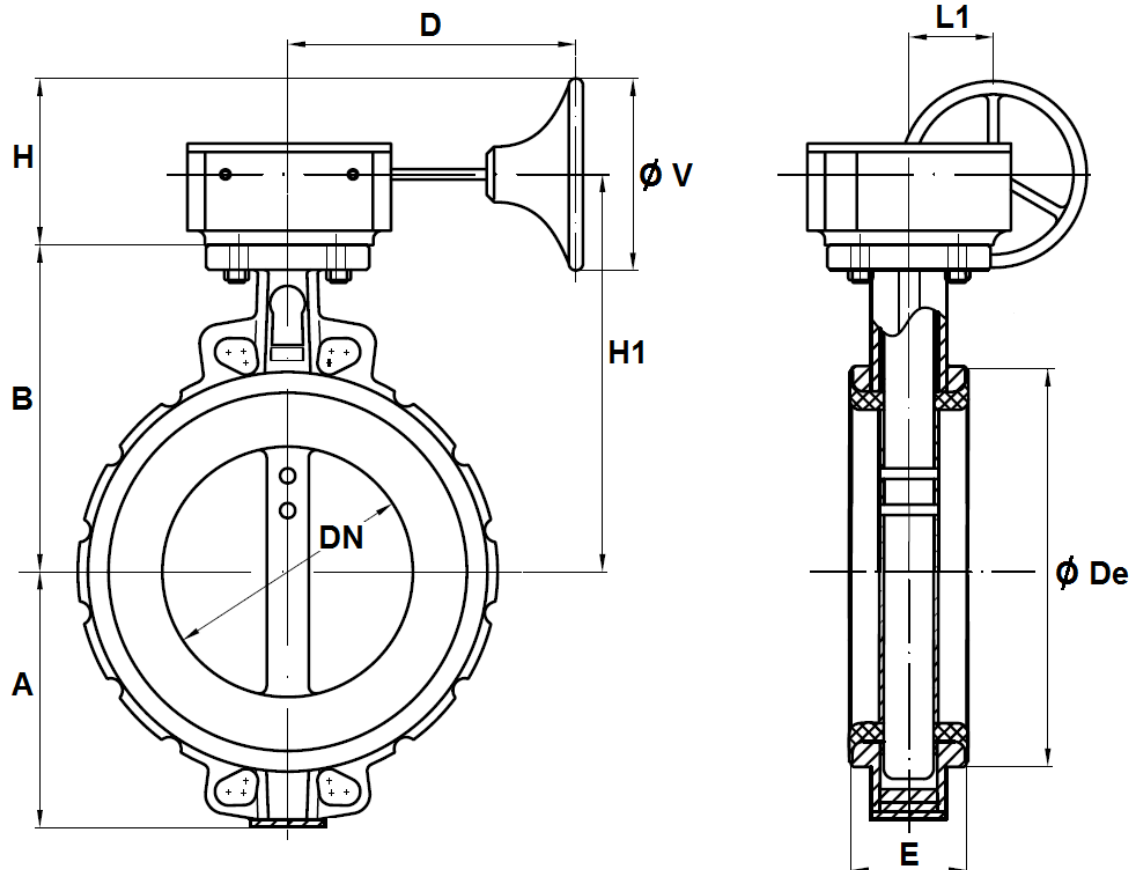

Ref.	DN	400	450	500	600
1123	A	307	339	368	459
	B	361	401	480	565
	D	270	270	339	339
	Ø De	470	525	570	697
	E	102	114	127	154
	H	208	258	222	222
	H1	423	463	545	630
	L1	120	120	120	120
	Ø V	400	400	300	300
	Weight (Kg)		89.85	107.4	155.8

**WAFER BUTTERFLY VALVE PN10/16**

VALVES SIZE ( in mm ) :

- VALVES WITH GEAR BOX DN 700-1200 :

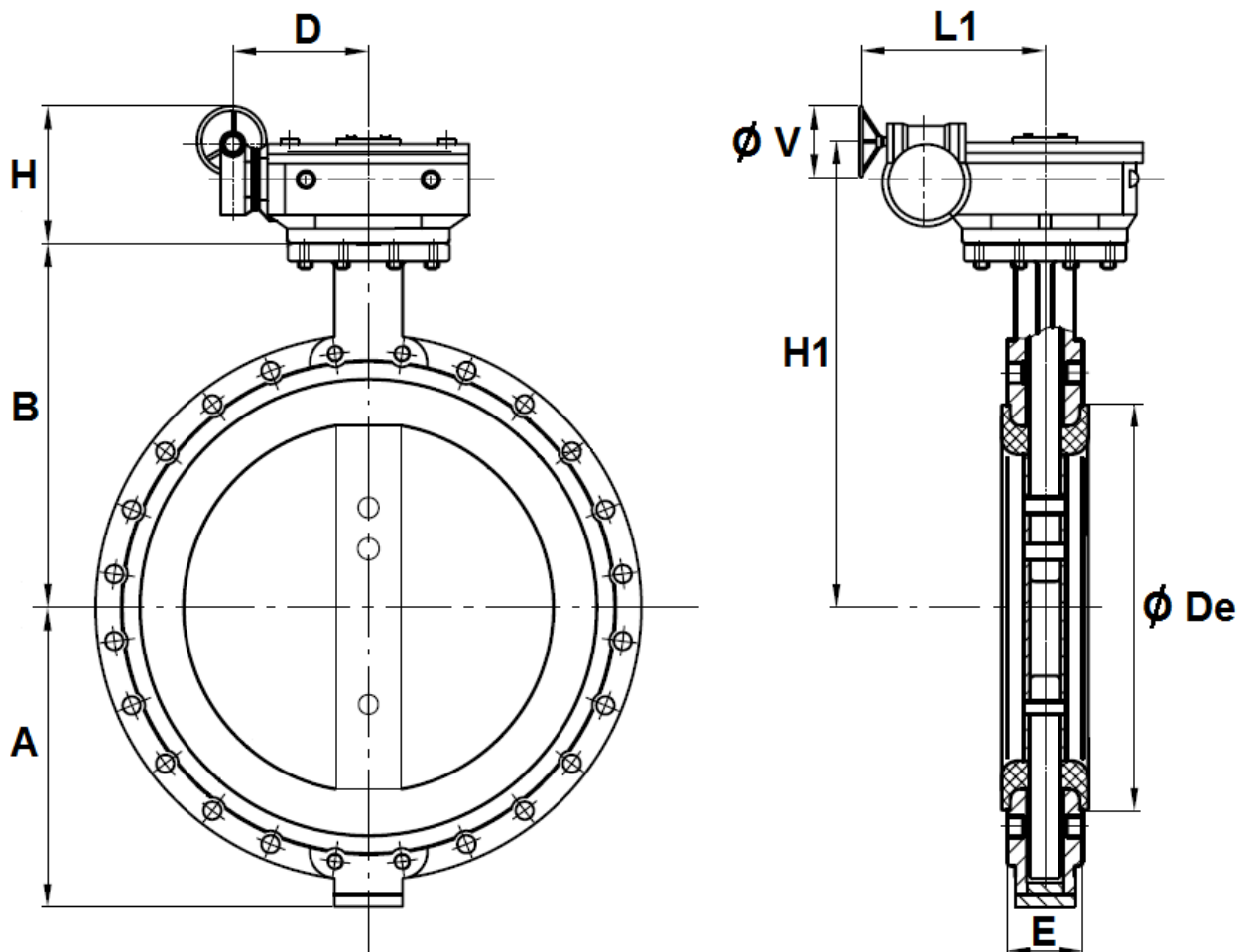

Ref.	DN	700	800	900	1000	1200
1123	A	520	591	656	721	860
	B	624	672	720	800	941
	D	367	367	410	410	500
	Ø De	800	906	1015	1134	1331
	E	163	188	203	216	276
	H	382	382	476	476	528
	H1	725	785	944	994	1228
	L1	243	243	278	278	458
	Ø V	400	400	450	450	450
	Weight (Kg)	372	456	831	982	1510



**WAFER BUTTERFLY VALVE PN10/16**

GEAR BOX SIZE DN32/40-300 ( in mm ) :

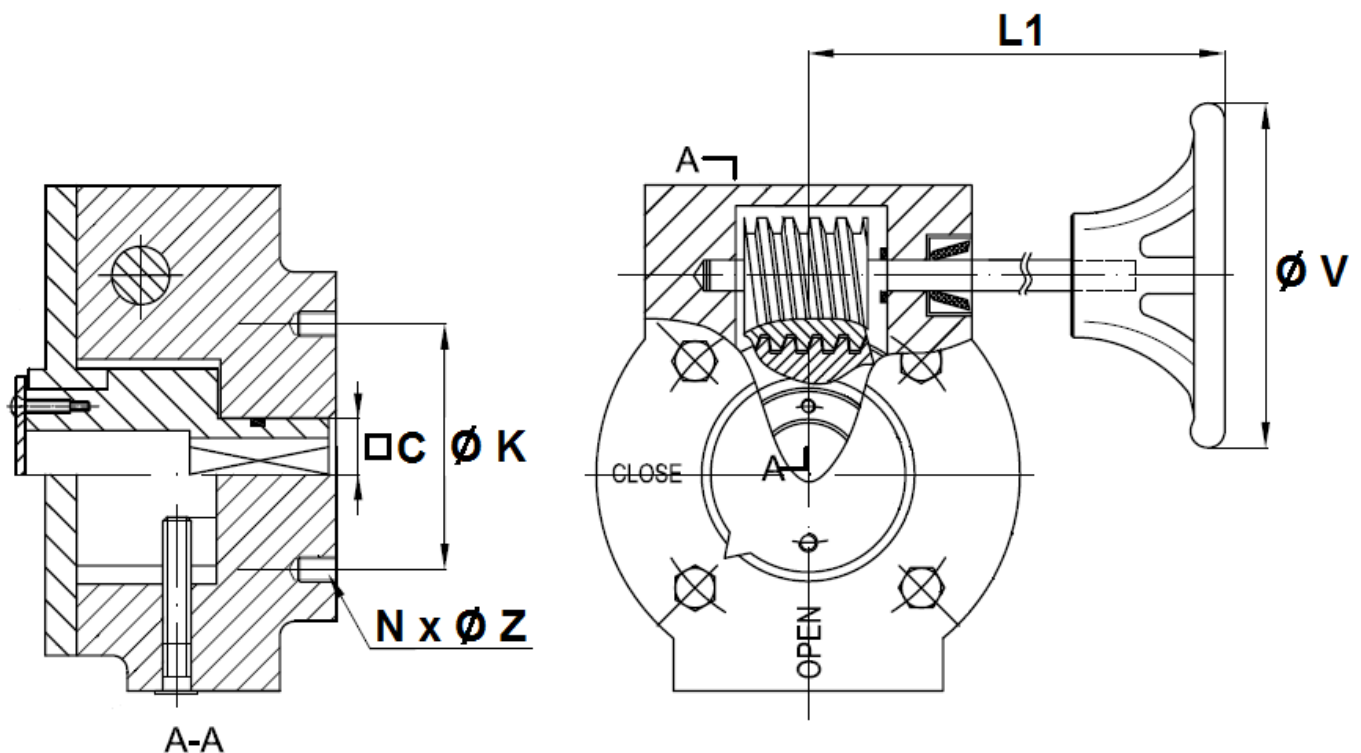

DN	32/80	100	125/150	200	250	300
C	9	11	14	17	22	27
$\varnothing K$	50	50	70	102	125	125
$N \times \varnothing Z$	4 x M6	4 x M6	4 x M8	4 x M10	4 x M12	4 x M12
L1	156	156	156	241	223	223
$\varnothing V$	150	150	250	300	300	300
Weight (kg)	3.51	4.22	3.53	6.99	7.42	9.6
Ref.	1198001	1198002	1198003	1198004	1198005	1198006

**WAFER BUTTERFLY VALVE PN10/16**

DISC AND NECK SIZE ( in mm ) :

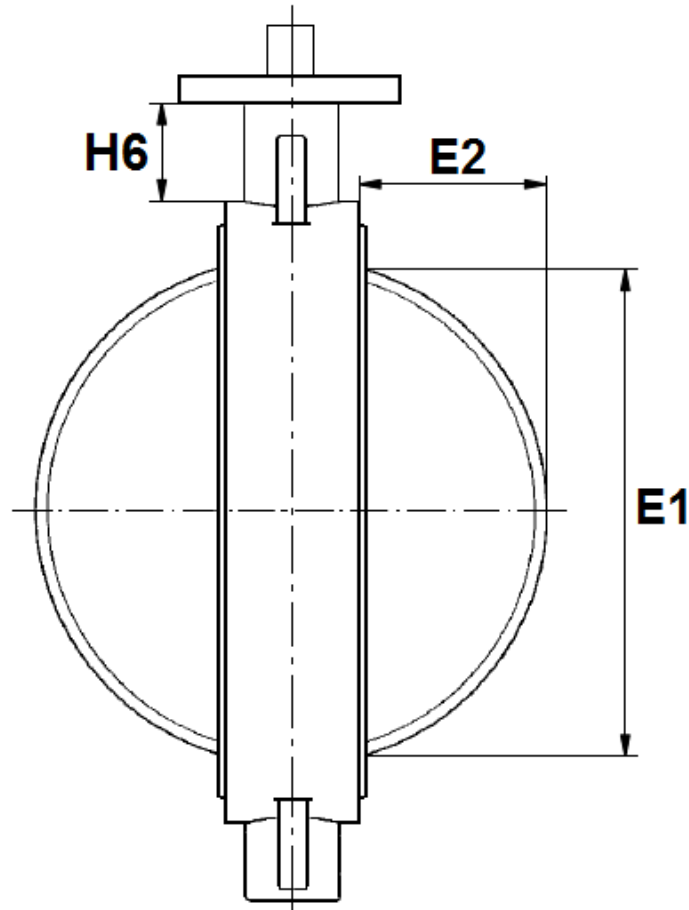

DN	32/40	50	65	80	100	125	150	200	250	300	350	400	450	500	600
E1 ±1	22.8	26	41.2	61.1	88	109.2	144	192.3	240	290.5	323.4	375	424.5	473.7	570.9
E2 ±2	4.9	5	9.4	16.5	26.1	33.9	49.7	71.2	91.2	111.8	127.8	143.9	163.3	182.3	219.3
H6 ±2	76.7	79	79	87.5	92.3	90.3	99.2	99.5	103.8	105.8	105.8	109.5	113	172	192

DN	700	750	800	900	1000	1200
E1 ±1	672.8	723.5	770.1	838.5	937	1122.1
E2 ±2	265.3	288.5	303.2	330.8	373.7	441
H6 ±2	200	201	190	179	206.5	228

**WAFER BUTTERFLY VALVE PN10/16**

ISO MOUNTING PAD SIZE ( in mm ) DN 32 – 600 :

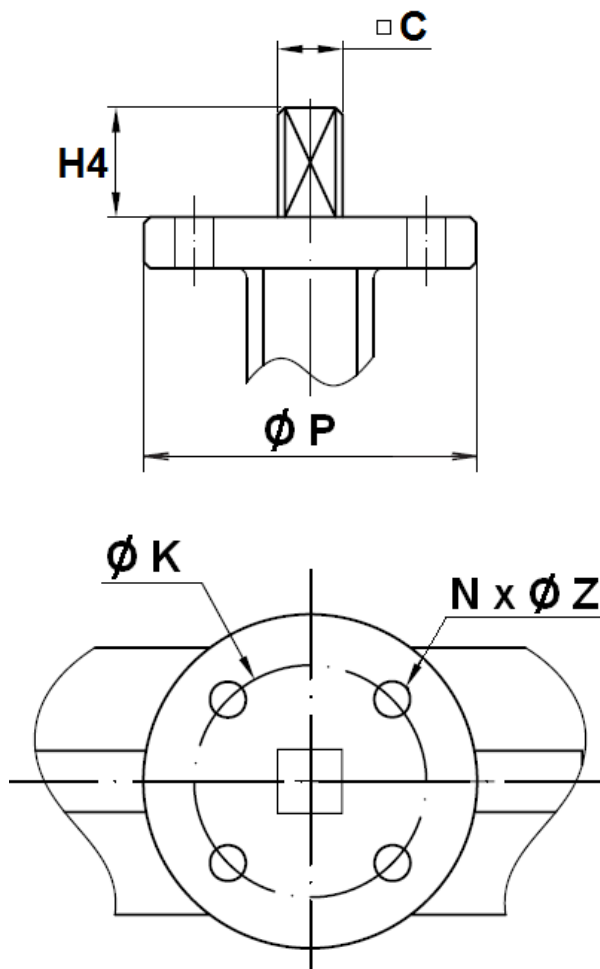

DN	32/40	50	65	80	100	125	150	200	250	300	350	400	450	500	600
C	9	9	9	9	11	14	14	17	22	27	27	27	30	36	46
$\varnothing K$	50	50	50	50	50	70	70	102	125	125	125	125	165	165	165
ISO	F05	F05	F05	F05	F05	F07	F07	F10	F12	F12	F12	F12	F16	F16	F16
$N \times \varnothing Z$	4 x 7	4 x 7	4 x 7	4 x 7	4 x 7	4 x 9	4 x 9	4 x 11	4 x 13	4 x 13	4 x 14	4 x 14	4 x 22	4 x 22	4 x 22
H4	32	32	32	32	32	42	42	36	38	38	45	50	50	65	70
$\varnothing P$	65	65	65	65	65	90	90	125	150	150	150	150	210	210	300

**WAFER BUTTERFLY VALVE PN10/16**

ISO MOUNTING PAD SIZE ( in mm ) DN 700 – 1200 :

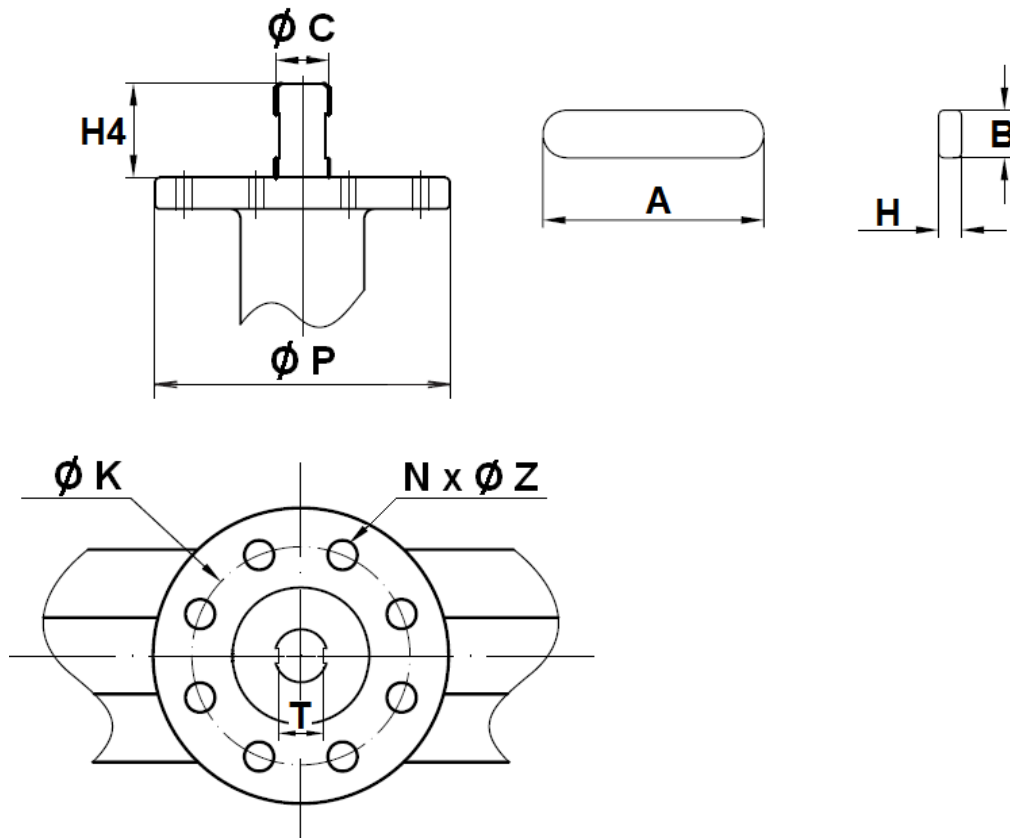

DN	700	800	900	1000	1200
$\phi C$	63.35	63.35	75	85	105
$\phi K$	254	254	254	254	298
ISO	F25	F25	F25	F25	F30
$N \times \phi Z$	8 x 18	8 x 18	8 x 18	8 x 18	8 x 22
H4	80	80	118	142	150
$\phi P$	300	300	300	300	350
A	60	60	100	110	110
B	18	18	20	22	28
H	11	11	12	14	16

**WAFFER BUTTERFLY VALVE PN10/16**
**GEARBOX SPECIFICATIONS :**

DN	32/80	100	125/150	200	250	300
Ref.	1198001	1198002	1198003	1198004	1198005	1198006
Ratio factor	24 :1	24 :1	24 :1	30 :1	30 :1	50 :1
Input torque (Nm)	18	18	18	58	58	60
Output torque (Nm)	170	170	170	700	700	1200

DN	350	400	450	500	600	700	800	900	1000	1200
Ratio factor	50 :1	80 :1	80 :1	260 :1	300 :1	704 :1	704 :1	832 :1	832 :1	1056 :1
Input torque (Nm)	60	78	78	30	45	95	95	178	178	260
Output torque (Nm)	1200	2500	2500	2500	4000	8000	8000	15000	15000	25000

**STANDARDS :**

- Fabrication according to ISO 9001 :2008
- Designing according to API 609
- DIRECTIVE 97/23/CE : CE N° 0035  
Risk category I-III module H
- Tests according to API 598
- Length according to ISO 5752 series 20, EN 558 series 20 ( NF 29305 )
- ISO 5211 mounting pad
- Between flanges according to EN 1092-2 PN10/16 and ASME B16.5 ISO PN20 ANSI150

ADVICE :Our opinion and our advice are not guaranteed and Lauridsen Industri shall not be liable for the consequences of damages.

The customer must check the right choice of the products with the real service conditions.

**WAFER BUTTERFLY VALVE PN10/16**

**INSTALLATION INSTRUCTIONS**

**GENERAL GUIDELINES :**

- Ensure that the valves to be used are appropriate for the conditions of the installation (type of fluid, pressure and temperature).
- Be sure to have enough valves to be able to isolate the sections of piping as well as the appropriate equipment for maintenance and repair.
- Ensure that the valves to be installed are of correct strength to be able to support the capacity of their usage.
- **Installation of all circuits should ensure that their function can be automatically tested on a regular basis (at least two times a year).**

**INSTALLATION INSTRUCTIONS :**

- **Before installing the valves, clean and remove any objects from the pipes** (in particular bits of sealing and metal) which could obstruct and block the valves.
- **Ensure that both connecting pipes either side of the valve (upstream and downstream) are aligned (if they're not, the valves may not work correctly).**
- **Make sure that the two sections of the pipe (upstream and downstream) match, the valve unit will not absorb any gaps. Any distortions in the pipes may affect the tightness of the connection, the working of the valve and can even cause a rupture.** To be sure, place the kit in position to ensure the assembling will work.
- **If sections of piping do not have their final support in place, they should be temporarily fixed. This is to avoid unnecessary strain on the valve.**
- The valve must be inserted between flanges with disc half opened but the disc must not overpass the valve thickness. Position the bolts to keep centered the valve. Then open fully the valve and tighten the bolts. **See graph under.**

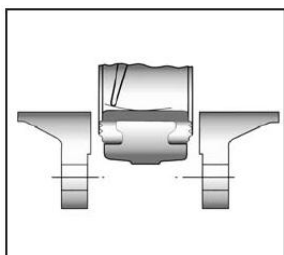

Half open valve introduction

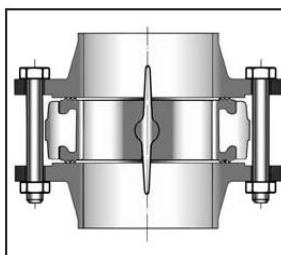

Complete opened disc valves when screw tightening

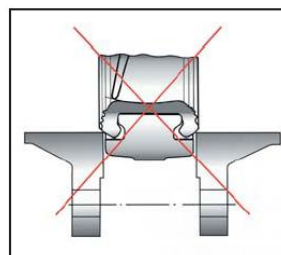

- Tighten the bolts in cross.
- The disc must move easily inside the pipe.
- Valves must be opened during cleaning operation.
- Tests must be done with a cleaned pipe.
- Tests must be done with opened valve. Test pressure must not be higher than the valve specification according to API 598.
- Then open slowly the valve.
- **Do not mount butterfly valves with stainless steel pressed collars and turning flanges without strias.**
- **And not on flat face flanges without strias ( example : painted cast iron fittings )**

**WAFER BUTTERFLY VALVE PN10/16****MAINTENANCE :**

- We recommend to operate fully the valve 1 to 2 times per year.
- During maintenance operation, ensure that the pipe isn't under pressure, that there's no fluid in the pipe and that the valve is isolated. If there's a fluid in the pipe , evacuate it. Ensure that there are no risks due to the temperature or the fluid ( like acids ). If the fluid is corrosive , inert the installation before maintenance operation.