

STAINLESS STEEL GLOBE VALVE PN16

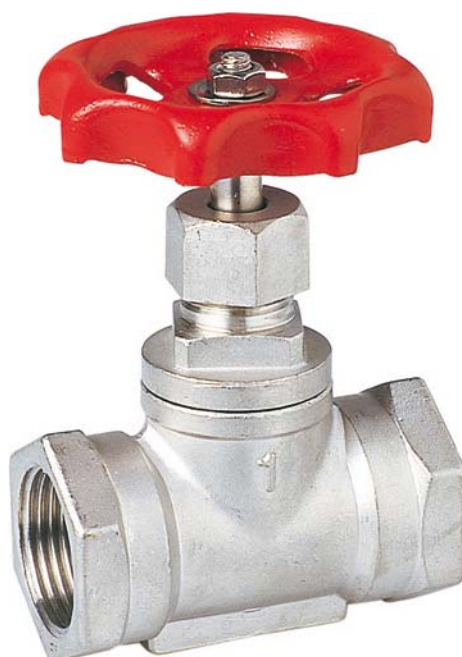

Lloyd's
Register
ISO 9001 : 2015



Lloyd's
Register
PED/2014/68/EU



Certificate 3.1

Size : DN 1/2" to 2"
Ends : Female - Female BSP
Min Temperature Mini : - 20°C
Max Temperature Maxi : + 180°C
Max Pressure : 16 Bars
Specifications : Rising rotating stem and handwheel
PTFE packing
Reduced bore

Materials : S.S. ASTM A351 CF8M

STAINLESS STEEL GLOBE VALVE PN16

SPECIFICATIONS :

- Respect the flow direction (indicated by the arrow)
- Rising rotating stem and handwheel
- PTFE packing
- S.S. ASTM A351 CF8M body
- Reduced bore
- Threaded female BSP cylindrical

USE :

- For common fluids
- Min and max Temperature Ts : - 20°C to + 180°C
- Max Pressure Ps : 16 bars (see graph)
- **Do not use for steam**

PRESSURE / TEMPERATURE GRAPH (STEAM EXCLUDED) :

PRESSURE

BAR

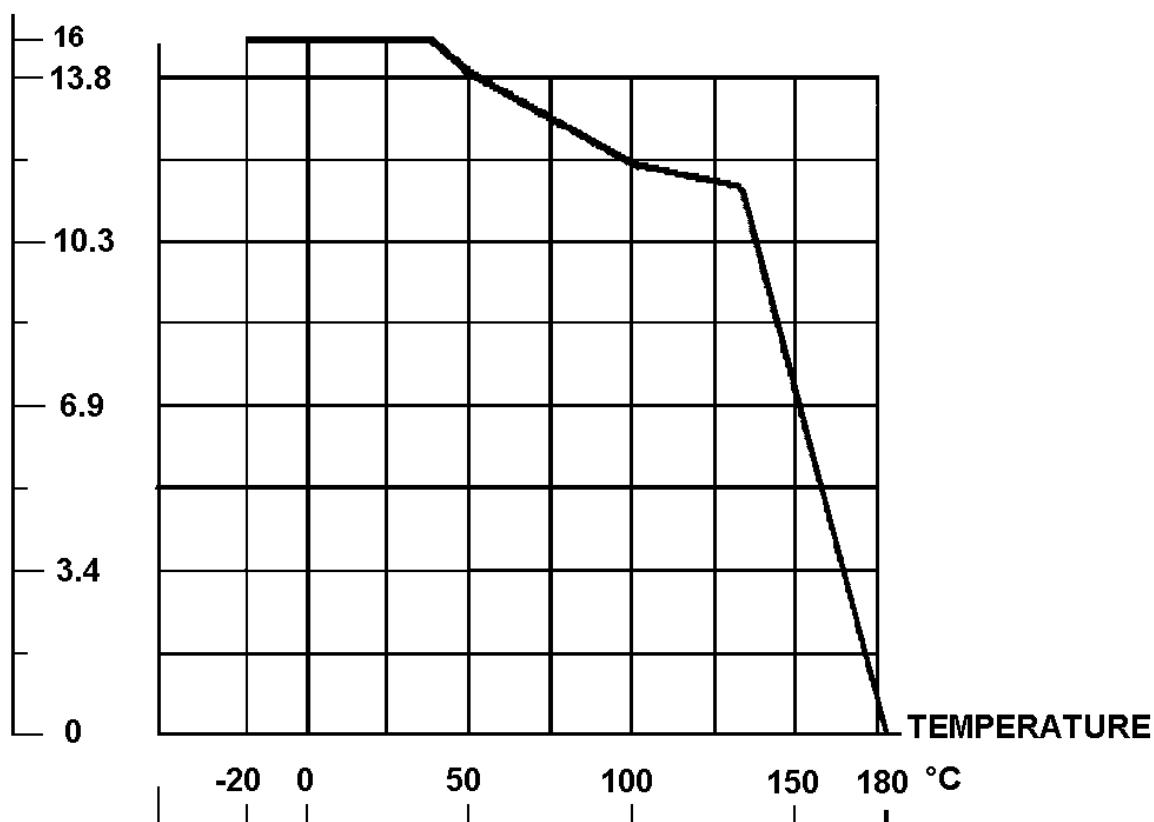

STAINLESS STEEL GLOBE VALVE PN16

HEAD LOSS GRAPH :

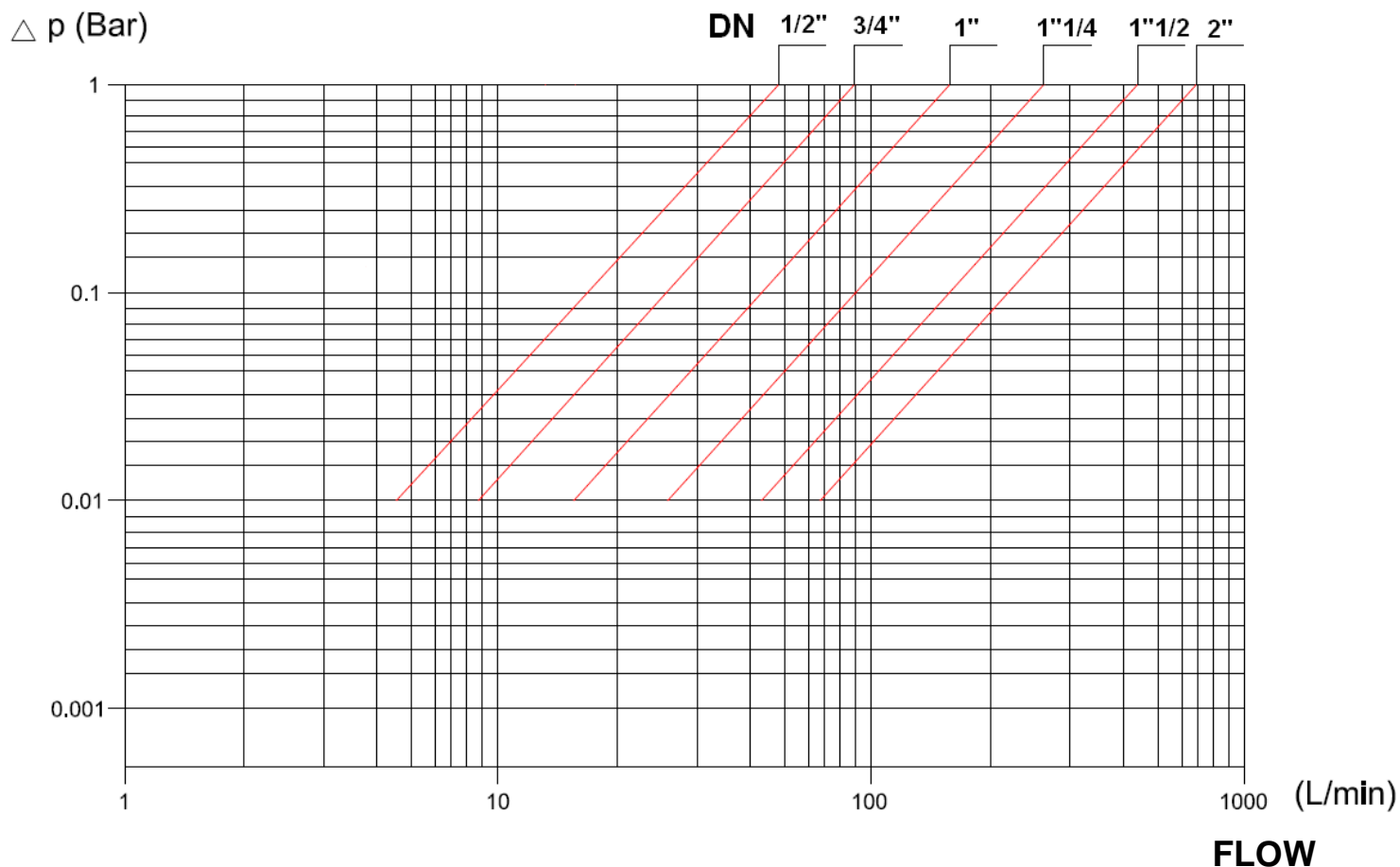

FLOW COEFFICIENT Kvs (M3 / h) :

DN	1/2"	3/4"	1"	1 1/4"	1 1/2"	2"
Kvs (m3/h)	1.88	3.06	5.67	9.05	15.18	24.94

RANGE :

- Globe valve female threaded cylindrical BSP from DN 1/2" to DN 2" **Ref. 485**

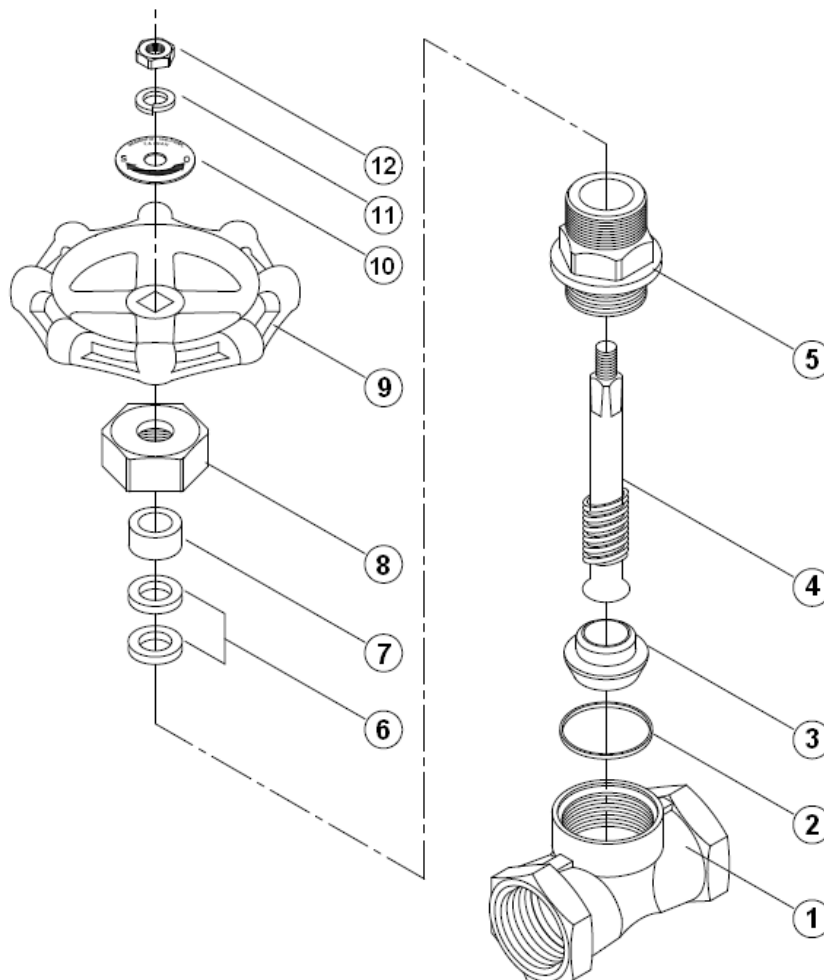
STAINLESS STEEL GLOBE VALVE PN16
MATERIALS :

Item	Designation	Materials
1	Body	ASTM A351 CF8M
2	Body seal	PTFE
3	Disc	AISI 316
4	Stem	
5	Bonnet	ASTM A351 CF8M
6	Packing	PTFE
7	Packing gland	AISI 304
8	Packing nut	ASTM A351 CF8M
9	Handwheel	Steel
10	Name plate	AISI 304
11	Washer	AISI 316
12	Nut	AISI 304

STAINLESS STEEL GLOBE VALVE PN16

SIZE (in mm) :

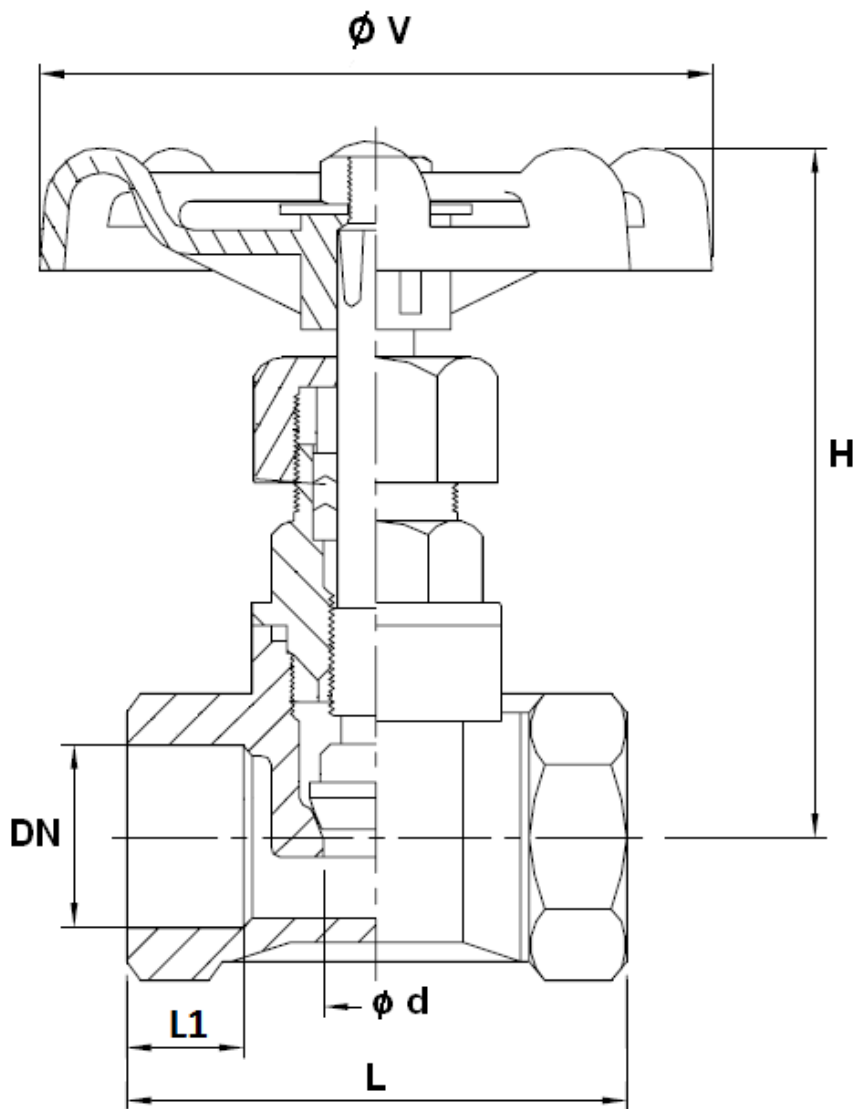

Ref.	DN	1/2"	3/4"	1"	1"1/4"	1"1/2"	2"
485	Ø d	12	15	20	25	32	40
	L	52	60	72	81	90	101
	L1	12.5	13	17.5	19	20	20
	H (opened)	79	91	105	127	142	158
	Ø V	70	70	80	80	90	100
	Weight (in Kg)	0.26	0.44	0.60	0.96	1.22	1.74

STAINLESS STEEL GLOBE VALVE PN16

STANDARDS :

- Fabrication according to ISO 9001 : 2015
- DIRECTIVE 2014/68/EU : Risk category I module A
- Certificate 3.1 on request
- Pressure tests according to EN 12266-1, D Rate
- Threaded BSP female cylindrical according to ISO 228-1

ADVICE : Our opinion and our advice are not guaranteed and Lauridsen industri shall not be liable for the consequences of damages. The customer must check the right choice of the products with the real service conditions.

STAINLESS STEEL GLOBE VALVE PN16**INSTALLATION INSTRUCTIONS****GENERAL GUIDELINES :**

- Ensure that the valves to be used are appropriate for the conditions of the installation (type of fluid, pressure and temperature).
- Be sure to have enough valves to be able to isolate the sections of piping as well as the appropriate equipment for maintenance and repair.
- Ensure that the valves to be installed are of correct strength to be able to support the capacity of their usage.
- **Installation of all circuits should ensure that their function can be automatically tested on a regular basis (at least two times a year).**

INSTALLATION INSTRUCTIONS :

- **Before installing the valves, clean and remove any objects from the pipes** (in particular bits of sealing and metal) which could obstruct and block the valves.
- **Ensure that both connecting pipes either side of the valve (upstream and downstream) are aligned (if they're not, the valves may not work correctly).**
- **Make sure that the two sections of the pipe (upstream and downstream) match, the valve unit will not absorb any gaps. Any distortions in the pipes may affect the tightness of the connection, the working of the valve and can even cause a rupture.** To be sure, place the kit in position to ensure the assembling will work.
- The theoretical lengths given by ISO/R7 for the tapping are typically longer than required, the length of the thread should be limited, and **check that the end of the tube does not press right up to the head of the thread.**
- **Never use a vice to tighten the fixings of the valve.**
- **If sections of piping do not have their final support in place, they should be temporarily fixed. This is to avoid unnecessary strain on the valve.**
- **It may be necessary to screw the packing gland during using according to the type of use.**
- **Do not use a tool to shut the valve**
- **Fluids in the valve must not contain solid objects (it could damaged the seat).**
- It's recommended to operate the valve (open and close) 1 to 2 times per year