



**STAINLESS STEEL WAFER SPRING CHECK VALVE PN40**

Model/Ref: 386



*Partnership.  
Without Limits.*

[www.lauridsenindustri.dk](http://www.lauridsenindustri.dk)

**STAINLESS STEEL WAFER SPRING CHECK VALVE PN40**



ISO 9001:2008

BUREAU VERITAS  
Certification



**Size :** DN 15 to DN100  
**Ends :** Between flanges ISO PN10/16/25/40 and ANSI150  
**Min Temperature :** - 20°C  
**Max Temperature :** + 200°C  
**Max Pressure :** 40 Bars  
**Specifications :** Spring type  
All positions  
Metal / metal

**Materials :** Stainless steel

**STAINLESS STEEL WAFER SPRING CHECK VALVE PN40**
**SPECIFICATIONS :**

- Spring type
- All positions (respect the flow direction indicated by the arrow )
- Short length
- Disc rib guide for a better centering
- Full stainless steel corrosion resistant and for high temperature
- Metal / metal tightness

**USE :**

- Chemical and pharmaceutical industries, petrochemical industries, hydraulic installation, compressed air
- Min Temperature Ts : - 20°C
- Max Temperature Ts :+ 200°C
- Max Pressure Ps : 40 bars ( see graph under )

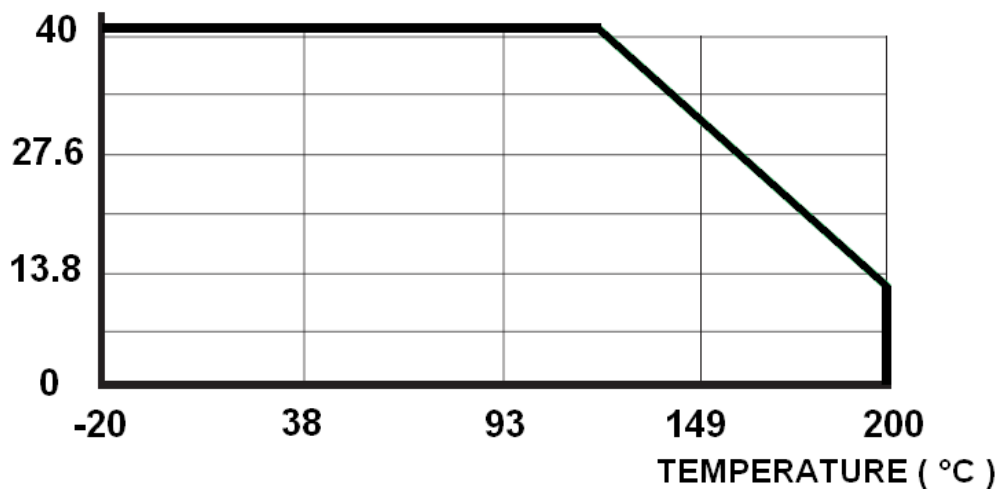
**PRESSURE / TEMPERATURE GRAPH ( STEAM EXCLUDED ) :**
**PRESSURE**
**( Bar )**

**FLOW COEFFICIENT Kvs ( M3 / h ) :**

DN	15	20	25	32	40	50	65	80	100
Kvs ( m3/h )	2.1	5.76	9.6	14.5	21.9	24.2	57.1	64.97	90.2

**RANGE :**

- Between ISO PN10/16/25/40 flanges and ISO PN20 ANSI 150\*\* **Ref. 386** from DN15 to DN100
- (\*) : For an installation between flanges ISO PN10/16 for DN100, we only use 4 bolts
- (\*\*) : For an installation between flanges ISO PN20 ANSI 150 for DN25, DN32 and DN40, use 4 bolts M12

STAINLESS STEEL WAFER SPRING CHECK VALVE PN40

HEAD LOSS GRAPH :

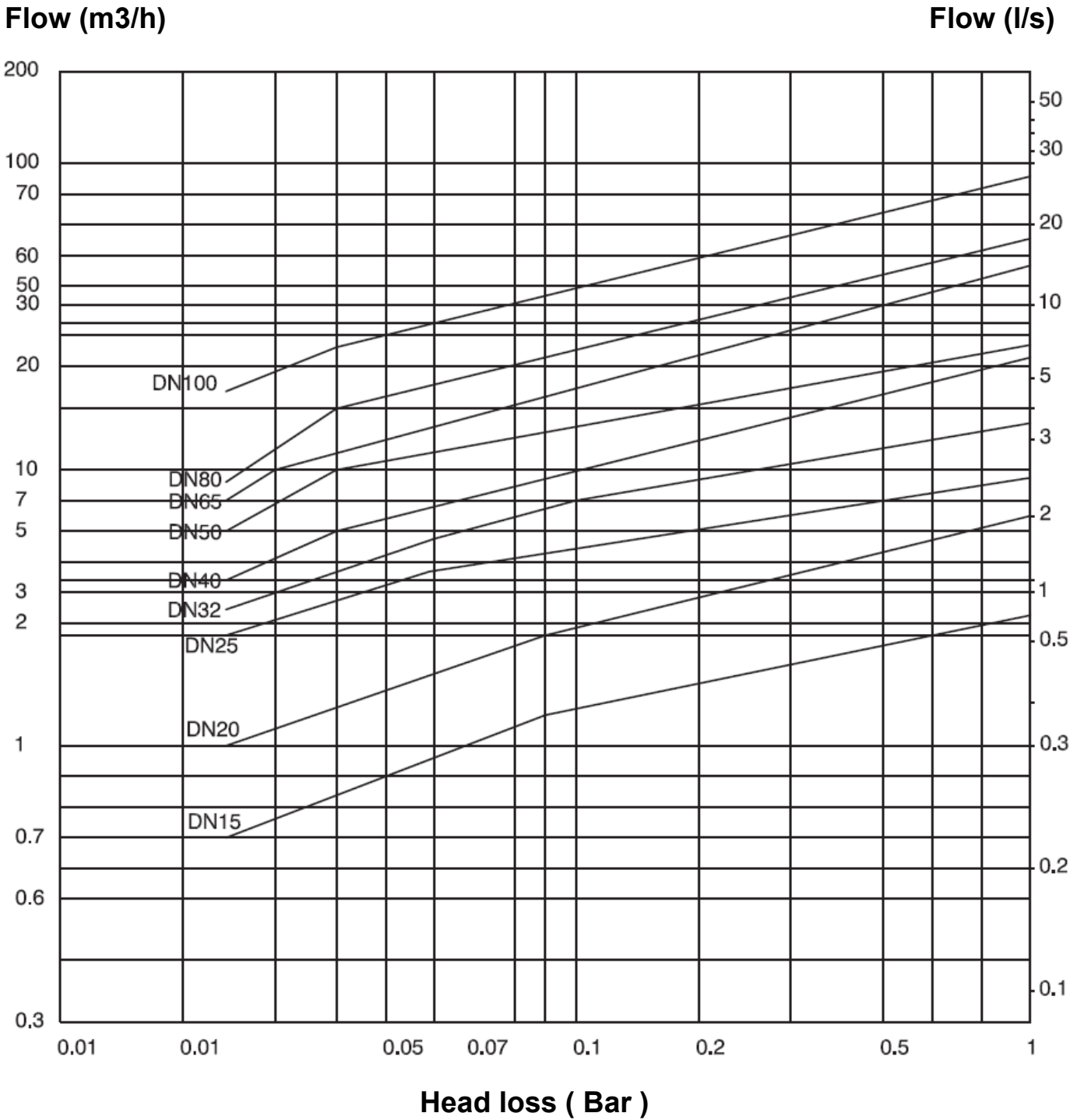

**STAINLESS STEEL WAFER SPRING CHECK VALVE PN40**

OPENING PRESSURE (in mbar) :

DN	Vertical Position Ascending fluid	Horizontal Position
DN 15	25 ↑	23 →
DN 20	25 ↑	23 →
DN 25	25 ↑	23 →
DN 32	27 ↑	24 →
DN 40	29 ↑	25 →
DN 50	29 ↑	25 →
DN 65	31 ↑	25 →
DN 80	32 ↑	26 →
DN100	33 ↑	27 →

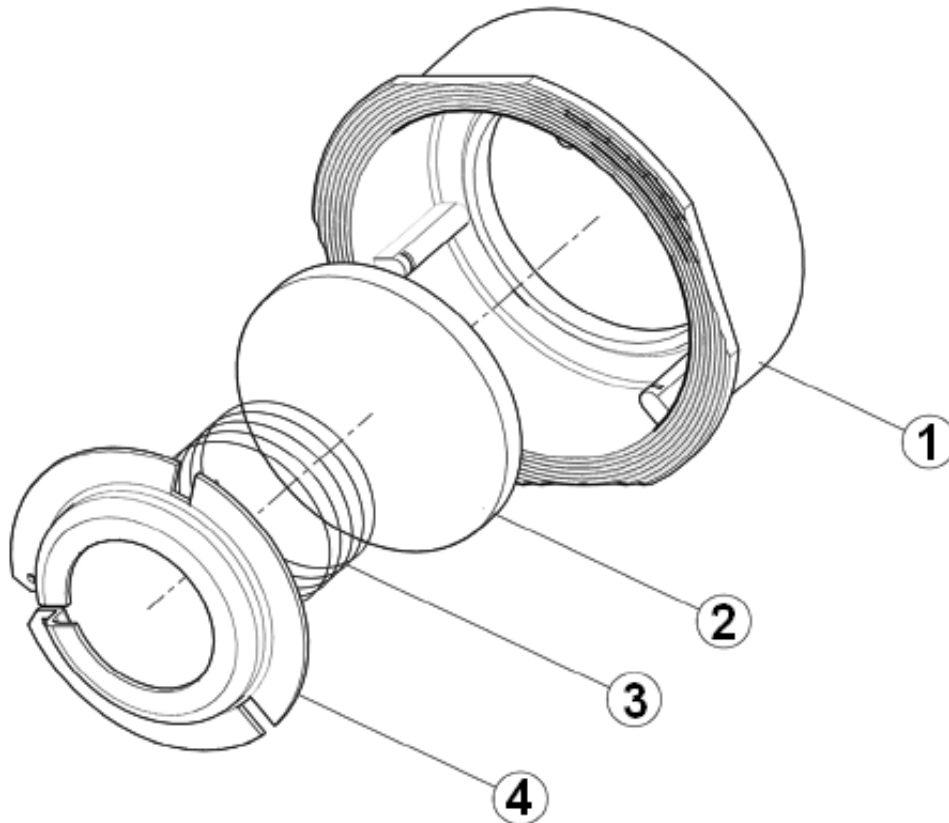
**STAINLESS STEEL WAFER SPRING CHECK VALVE PN40**
**MATERIALS :**

Item	Designation	Materials
1	Body	ASTM A351 CF8M
2	Disc	ASTM A240-316
3	Spring	SS 316
4	Spring holder	ASTM A240-316

**STAINLESS STEEL WAFER SPRING CHECK VALVE PN40**

SIZE ( in mm ) :

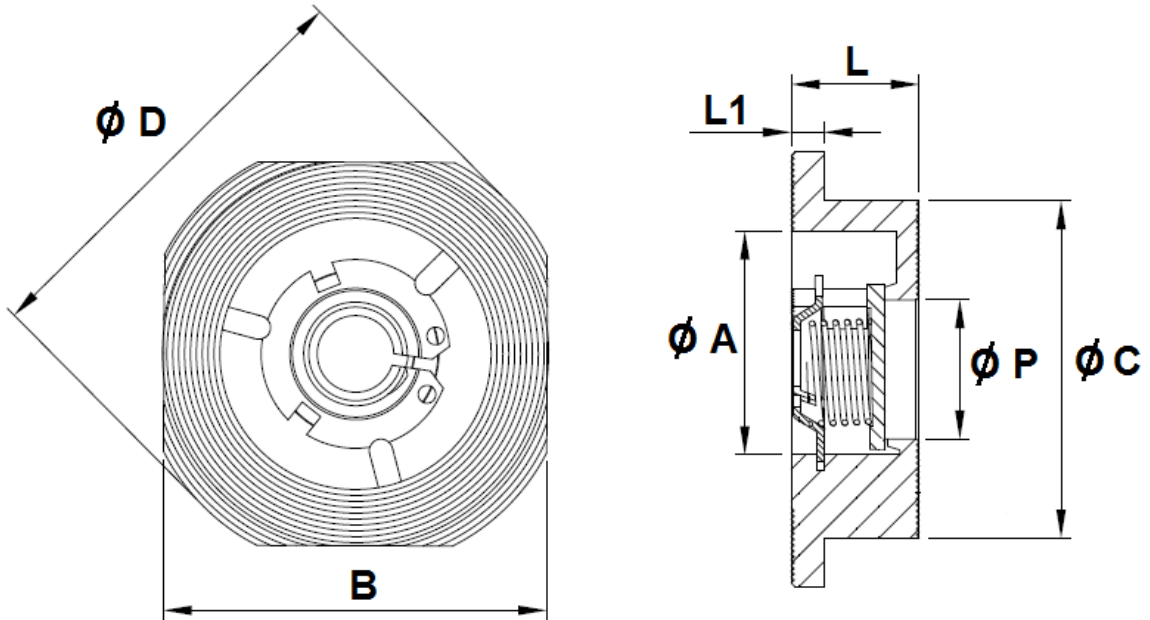

DN 15 – 80

DN100

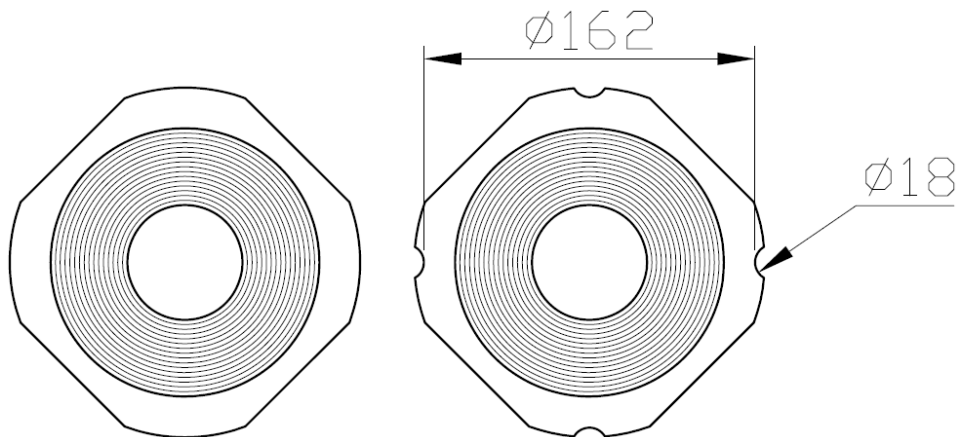

Ref.	DN	15	20	25	32	40	50	65	80	100
386	$\varnothing A$	34	39	46	60	70	79	101	109	134
	B	44.6	54	65	78	88	101.6	120.4	133	164
	$\varnothing C$	40.5	47	56	70	80	90	113	123	150
	$\varnothing D$	54	62	73	83	93	107	126.5	141.2	171.4
	L	16	19	22	28	31.5	40	46	49	60
	L1	3.5	3.5	4	5	5	5	5.5	5.5	6.5
	$\varnothing P$	12.5	20	25	32	38	49	64	78	98
	Weight ( Kg )	0.1	0.2	0.3	0.5	0.6	0.9	1.4	2	3

**STAINLESS STEEL WAFER SPRING CHECK VALVE PN40****STANDARDS :**

- Fabrication according to ISO 9001 : 2008
- DIRECTIVE 97/23/CE : CE N° 0035  
Risk Category III Module H
- Designing according to EN 12516-1
- Tests according to API 598, table 6
- Length according to EN 558 series 49 (DIN 3202 K4)
- ATEX Group II Category 2 G/2D Zone 1 & 21 Zone 2 & 22 ( optional marking )

ADVICE :Our opinion and our advice are not guaranteed and Lauridsen Industri shall not be liable for the consequences of damages.  
The customer must check the right choice of the products with the real service conditions.



STAINLESS STEEL WAFER SPRING CHECK VALVE PN40

**BOLTING POSTIONS :**

- **BETWEEN ISO PN10/16 FLANGES :**

**DN 15 – 50**

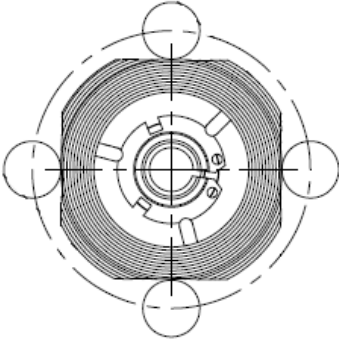

**DN 65 – 80**

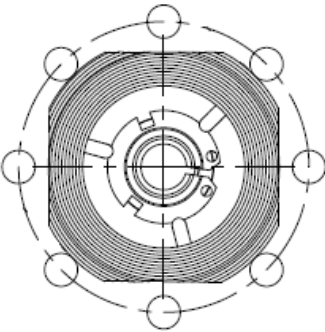

**DN 100**

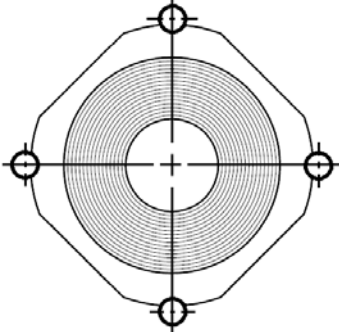

- **BETWEEN ISO PN25/40 FLANGES :**

**DN 15 – 50**

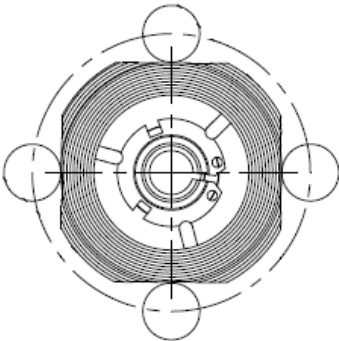

**DN 65 – 100**

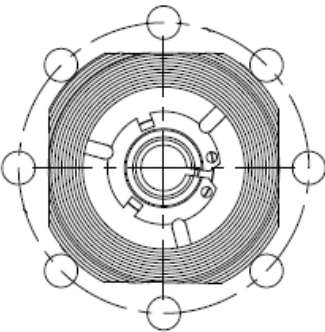

- **BETWEEN ISO PN20 ANSI 150 FLANGES :**

**DN 15 – 80**

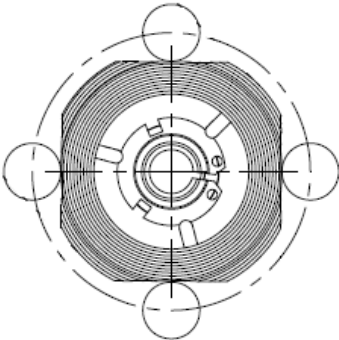

**DN 100**

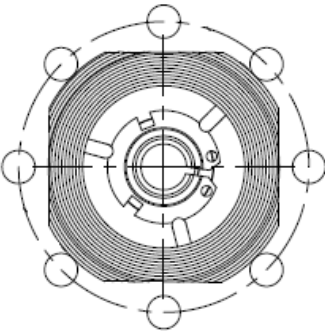

**STAINLESS STEEL WAFER SPRING CHECK VALVE PN40****INSTALLATION INSTRUCTIONS****GENERAL GUIDELINES :**

- Ensure that the check valves to be used are appropriate for the conditions of the installation (type of fluid, pressure and temperature).
- Be sure to have enough valves to be able to isolate the sections of piping as well as the appropriate equipment for maintenance and repair.
- Ensure that the valves to be installed are of correct strength to be able to support the capacity of their usage.

**INSTALLATION INSTRUCTIONS :**

- **Before installing the check valves, clean and remove any objects from the pipes** (in particular bits of sealing and metal) which could obstruct and block the valves.
- **Ensure that both connecting pipes either side of the check valve (upstream and downstream) are aligned (if they're not, the valves may not work correctly).**
- **Make sure that the two sections of the pipe (upstream and downstream) match, the check valve unit will not absorb any gaps. Any distortions in the pipes may affect the tightness of the connection, the working of the check valve and can even cause a rupture.** To be sure, place the kit in position to ensure the assembling will work.
- Make sure there is enough space so that the disc can be opened totally in the pipe.
- If there is a direction changing or if there's another material, it's better to take away the check valve so that it is outside the turbulence area ( **between 3 and 5 times the ND before and after** ).
- After a pump please refer to norm NF CR 13932 to install the check valve.