



**783-4-5-6 VALVE WITH NA ELECTRI  
ACTUATOR**

Model/Ref: 275377023120



*Partnership.  
Without Limits.*

[www.lauridsenindustri.dk](http://www.lauridsenindustri.dk)

**783-4-5-6 VALVE WITH NA ELECTRIC ACTUATOR**

**CHARACTERISTICS**

The 3-way stainless steel 783-5+NA (L-port) and 784-6+NA (T-port) ball valves are dedicated to the mixing, diverting or automatic discharging of industrial unloaded fluids. The valves with a DN from 50 to 80 have a floating ball construction and those with a DN from 100 to 150 have a trunnion mounted ball construction. They both have the EC and ATEX certifications. The ISO 5211 pad enables the direct mounting of the NA electric actuator. It is perfectly suitable for an indoor or outdoor industrial use.



**AVAILABLE ITEMS**

Ref.	Material	Port	Function
783	Carbon steel A216WCB	L	Diverting
784	Carbon steel A216WCB	T	Mixing
785	Stainless steel A351 CF8M	L	Diverting
786	Stainless steel A351 CF8M	T	Mixing

DN 50 to DN 150

Flanged connections RF PN16

Voltages: 24 V AC/DC, 230 V AC, 3~400 V AC

**LIMITS OF USE**

Max. allowable pressure (PS)	16 bar (20 °C)
Min./max. allowable temperature (TS)	Steel: -20 °C / +150 °C SS: -30 °C / +150 °C
Room temperature	-20 °C / +70 °C
Service	S2 – 70%

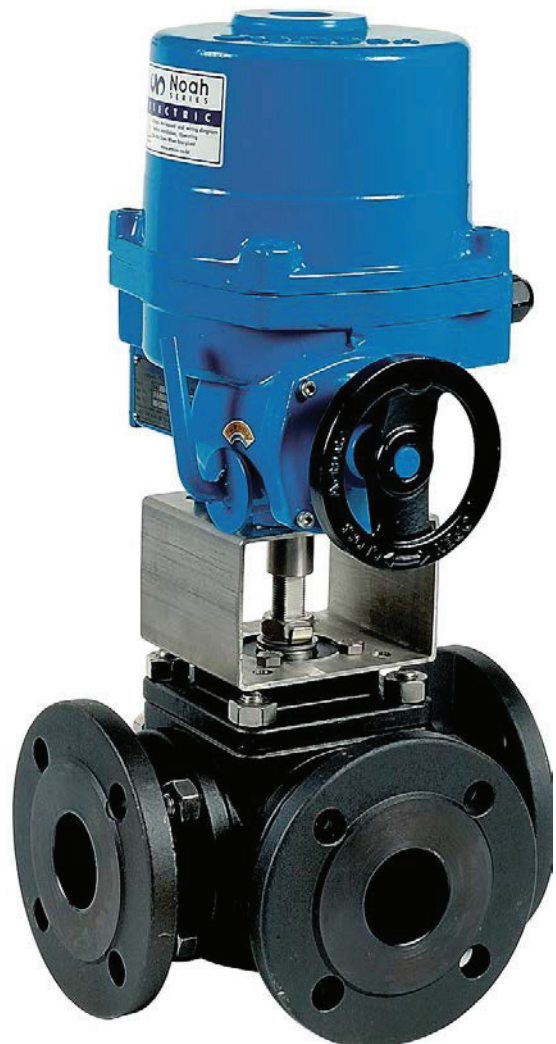
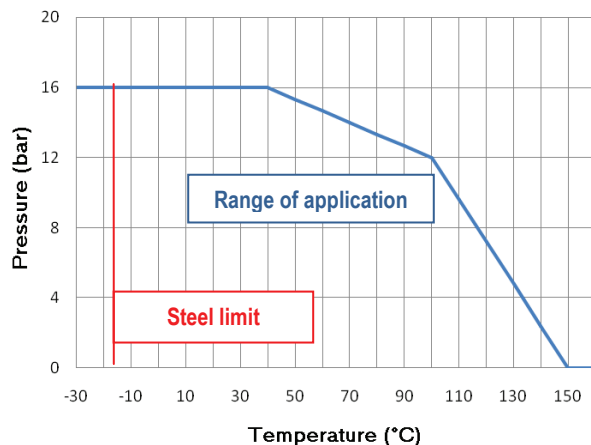

The following data is for information purpose only and may be subject to alteration without prior notice

**783-4-5-6 VALVE WITH NA ELECTRIC ACTUATOR**

**DIRECTIVES AND DEVELOPMENT STANDARDS APPLICABLE**

	Standard	Notified bodies		Standard
97/23/EC Pressure Equipment Directive	Category II	0035	Material certificate	EN 10204
Shell design	EN 12516-1		Alloy grade	EN 1503-1
Flanges dimension	EN 1092-1		Valve testing	EN 12266
ATEX Directive	II 2G/D Tx zones 1,2,21 and 22		Actuator attachment	ISO 5211
	EN 13463-1			

**CONSTRUCTION DN 50 to DN 80**

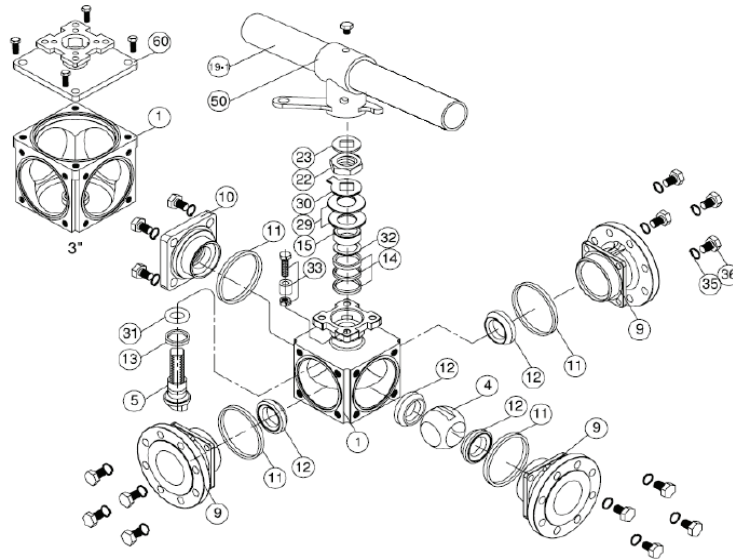

#	Item	783-784 CS	785-786 SS	#	Item	Material
1	Body	Carbon steel A216WCB	Stainless steel A351 CF8M	22	Gland pack nut	SS 304
4	Ball	SS 1.4308	Stainless steel A351 CF8M	23	Washer	SS 304
5	Stem	SS 304	SS 316	29	Belleville spring washer	SS 301
9	Ends	Carbon steel A216WCB	Stainless steel A351 CF8M	30	Locking washer	SS 304
10	Cap	Carbon steel A216WCB	Stainless steel A351 CF8M	31	O ring	FKM
11	Body gasket	PTFE		32	Gland packing	PTFE+15% Graphite
12	Seat	PTFE+15% Graphite		33	End stop	SS 304
13	Ring	PTFE		35	Washer	SS 304
14	Gland pack	PTFE		36	Screw	SS 304
15	Ring	SS 304		50	Handle adapter	SS 304
19	Handle	Steel				

The following data is for information purpose only and may be subject to alteration without prior notice

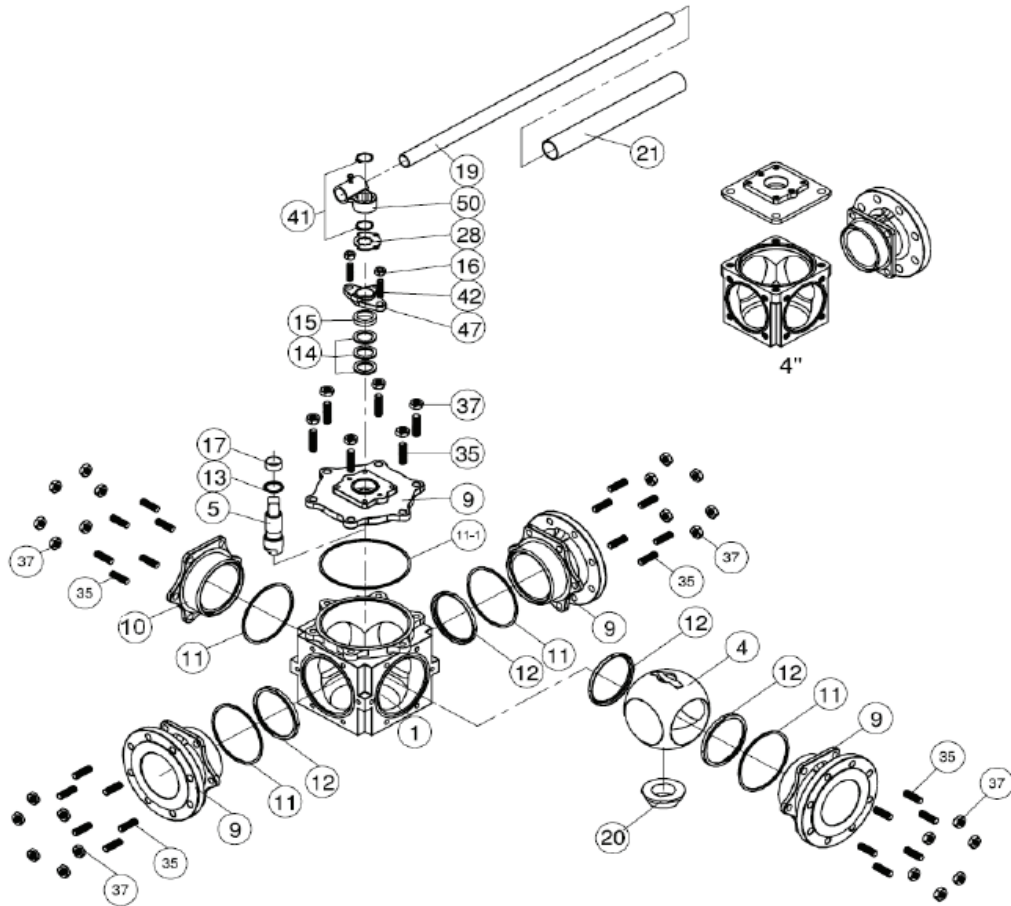
**783-4-5-6 VALVE WITH NA ELECTRIC ACTUATOR**
**CONSTRUCTION DN 100 to DN 150**

#	Item	783-784 CS	785-786 SS	#	Item	Material
1	Body	Carbon steel A216WCB	Stainless steel A351 CF8M	17	Stem gasket	PTFE
4	Ball	SS 1.4308	Stainless steel A351 CF8M	19	Handle	Steel
5	Stem	SS 304	SS 316	20	Guide screw	SS 304
9	Ends	Carbon steel A216WCB	Stainless steel A351 CF8M	21	Handle sleeve	PVC
10	Housing cover	Carbon steel A216WCB	Stainless steel A351 CF8M	28	Lock out system	SS 304
11	Body gasket	PTFE		35	Bolts	SS 304
11-1	Top body gasket	PTFE		37	Bolt screws	SS 304
12	Seat	PTFE+15% Graphite		41	Handle washer	SS 304
13	Ring	PTFE		42	Gland pack screw	SS 304
14	Gland pack	PTFE		47	Gland plate	SS 1.4308
15	Fixing ring	SS 304		50	Handle plate	SS 304
16	Gland pack nut	SS 304				

The following data is for information purpose only and may be subject to alteration without prior notice

**783-4-5-6 VALVE WITH NA ELECTRIC ACTUATOR**
**DIMENSIONS (mm)**

DN 50 to DN 80

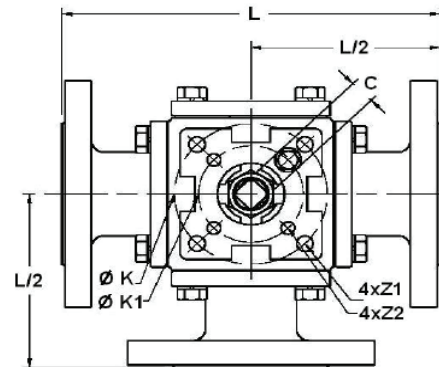
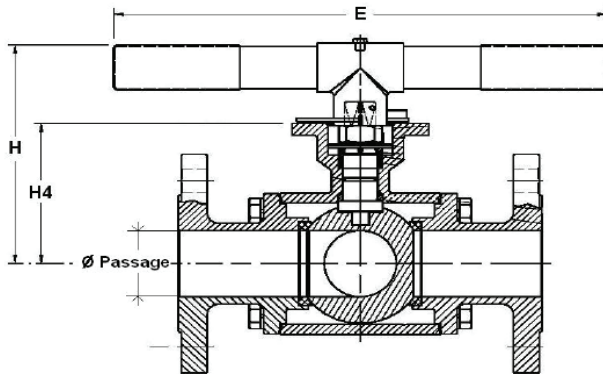

DN 100 to DN 150

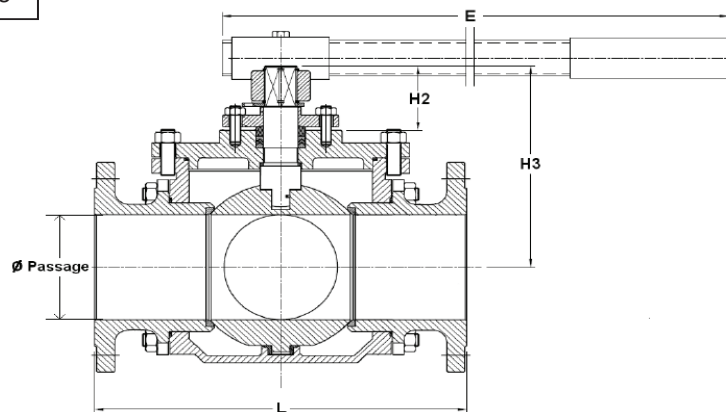

DN	50	65	80
Ø	49	64	76
L	253	278	292.2
L/2	126.5	139	146.1
E	300	300	300
H	156.6	168.9	178
H1	17.8	17.5	17.5
H4	105.8	117.3	128
C	17	17	17
Ø K	102	102	102
Ø K1	70	70	70
4 x Z1	4x11	4x11	4x11
4 x Z2	4x9	4x9	4x9
Weight (kg)	19	23.8	34.5

DN	100	125	150
Ø	99	125	150
L	360	416	473
L/2	180	203	236
E	600	600	800
H1	33	33	43.5
H2	70	70	77.5
H3	193	233	266
C	27	27	36
Ø K	125	125	140
4xZ	4x12	4x12	4x16
Weight (kg) L	67.4	95	124
Weight (kg) T	61.8	95	127

The following data is for information purpose only and may be subject to alteration without prior notice

**783-4-5-6 VALVE WITH NA ELECTRIC ACTUATOR**

**ELECTRIC ACTUATION WITH NA**

Suggested standard NA actuation under the following conditions:

- Electric actuator with an IP 67 epoxy coated aluminium enclosure and steel gears
- A minimum 1.3 safety factor compared with the valve nominal torque rating,
- A maximum pressure differential up/downstream of 10 bar (=ΔP)





Electric actuator mounted with stainless steel bracket and coupler according to the EN 15081 standard

DN	Actuator	Power	Operating time*	Standard equipment of the actuator
50	NA09	25 W	17 s	2 adjustable limit switches 2 dry auxiliary switches 20 W anti-condensation heater Visual position indicator Actuator thermal cut-out (NA06 and NA09) Torque limiter (NA15 to NA38) Electrical connection: 2 gland packs M20x1.5 Manual override by declutchable handwheel
65	NA15	40 W	20 s	
80	NA28	40 W	20 s	
100	NA28	40 W	20 s	
125	NA60	90 W	29 s	
150	NA60	90 W	29 s	

\*Unloaded operating time given for information purpose only. May vary depending on the medium  
 For any other working conditions, please contact us.

**ACTUATION OPTIONS**

There are many different options, please contact our commercial department.

1	2	3	4	5
NALCU: Actuator with a local control	NAPCU: Regulation actuator 4-20 mA or 0-10 V	NARBP: Safety actuator with an integrated battery emergency shutdown	NA-X: Actuator for use in ATEX zones 1 and 2	SR: Safety spring return actuator
				
6	Electric actuator sized for a maximum pressure differential up/downstream over 10 bar (=ΔP)			
7	NA electric actuator with a declutchable manual override by handwheel			

**ATEX ZONES INSTALLATION**

It is compulsory to specify if the installation of the automatic valve 783-4-5-6+NA-X will take place in ATEX zones 1 or 2 while making the order. Our services will proceed to the mounting check, to a grounding strip installation and will edit a mounting certificate. Those operations are performed by our proper engineers. Please contact us for further details. It is also compulsory to follow the ATEX zone mounting and maintenance special instructions for motorized valves. The ATEX gland packs and sealing plugs are not provided. Please use the following codes:

ATEX aluminium gland pack M20x1.5	Code 980179	ATEX aluminium sealing plugs M20x1.5	Code 980180
-----------------------------------	-------------	--------------------------------------	-------------

The following data is for information purpose only and may be subject to alteration without prior notice