



FLANGED BALL CHECK VALVE PN10

Model/Ref: 332



*Partnership.
Without Limits.*

www.lauridsenindustri.dk

FLANGED BALL CHECK VALVE PN10

Size : DN 40 to DN 300
Ends : ISO PN10/16 Flanges
Min Temperature : - 10°C
Max Temperature : + 80°C
Max Pressure : 10 Bars
Specifications : Ball type
Vertical or horizontal installation
Removable bonnet

Materials : Ductile iron

FLANGED BALL CHECK VALVE PN10

SPECIFICATIONS :

- Ball type
- Vertical with ascendant fluid or horizontal (respect the flow direction indicated by the arrow)
- ISO PN10/16 Flanges
- Removable bonnet
- Epoxy painting RAL 5005 blue color, 250 microns thickness

USE :

- Water distribution and watering
- Min Temperature Ts : - 10°C
- Max Temperature Ts : + 80°C
- Max Pressure PN : 10 bars

HEAD LOSS GRAPH :

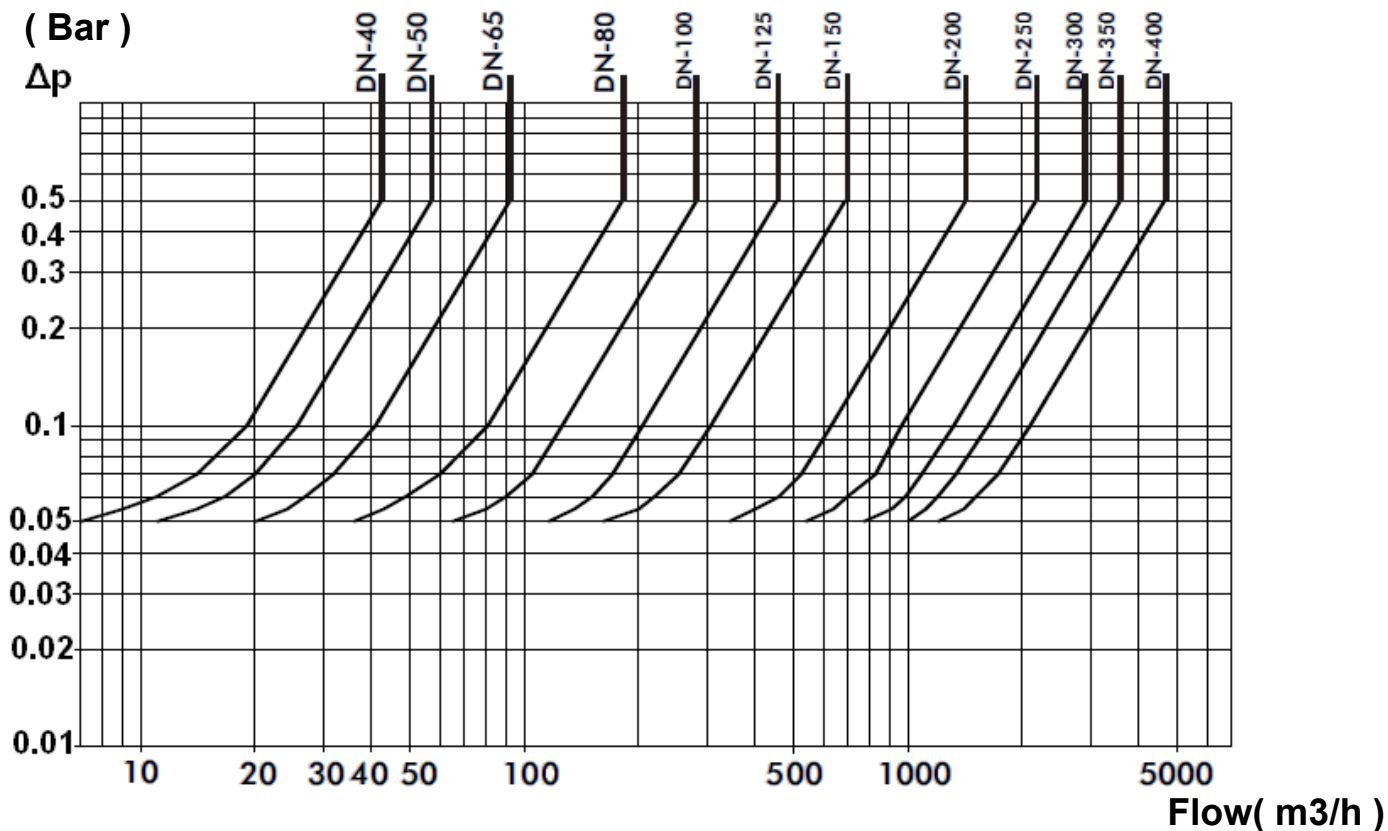

FLOW COEFFICIENT KV (in m3/h) :

DN	40	50	65	80	100	125	150	200	250	300
Kv (m3/h)	60	81	130	255	400	645	970	2000	3050	4150

FLANGED BALL CHECK VALVE PN10
RANGE :

- ISO PN10/16 Flanges from DN40 to 150 and ISO PN10 over **Ref. 332** from DN40 to 300

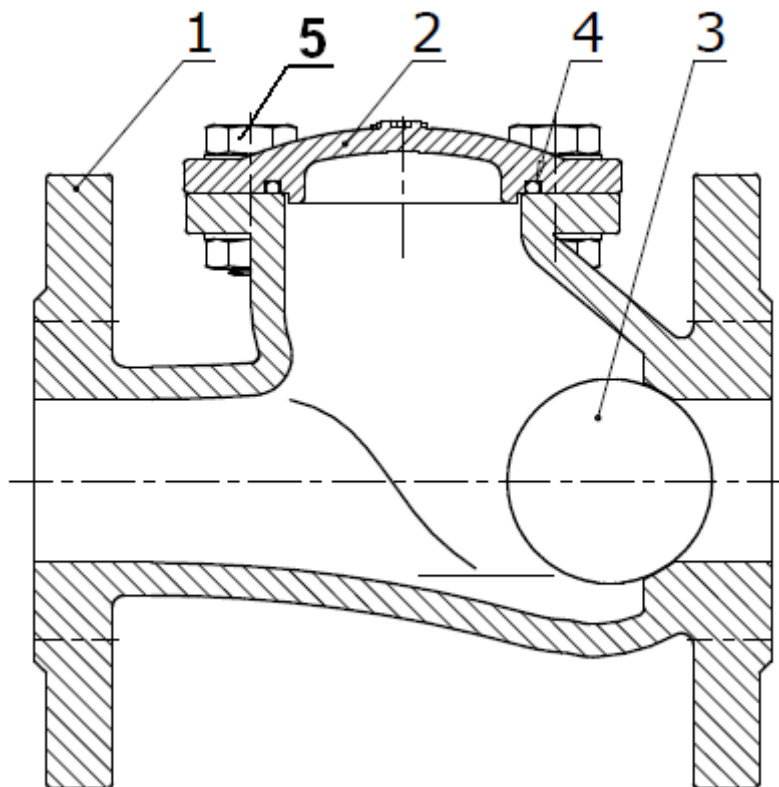
MATERIALS :

Item	Designation	Materials
1	Body	Ductile iron EN – GJS – 400-15
2	Bonnet	Ductile iron EN – GJS – 400-15
3	Ball DN 40	NBR
3	Ball DN 50 – DN80	Aluminium coated NBR
3	Ball DN 100 – 300	Carbon steel A216WCB coated NBR
4	Bonnet gasket	NBR
5	Bolting	SS 304

FLANGED BALL CHECK VALVE PN10

SIZE (in mm) :

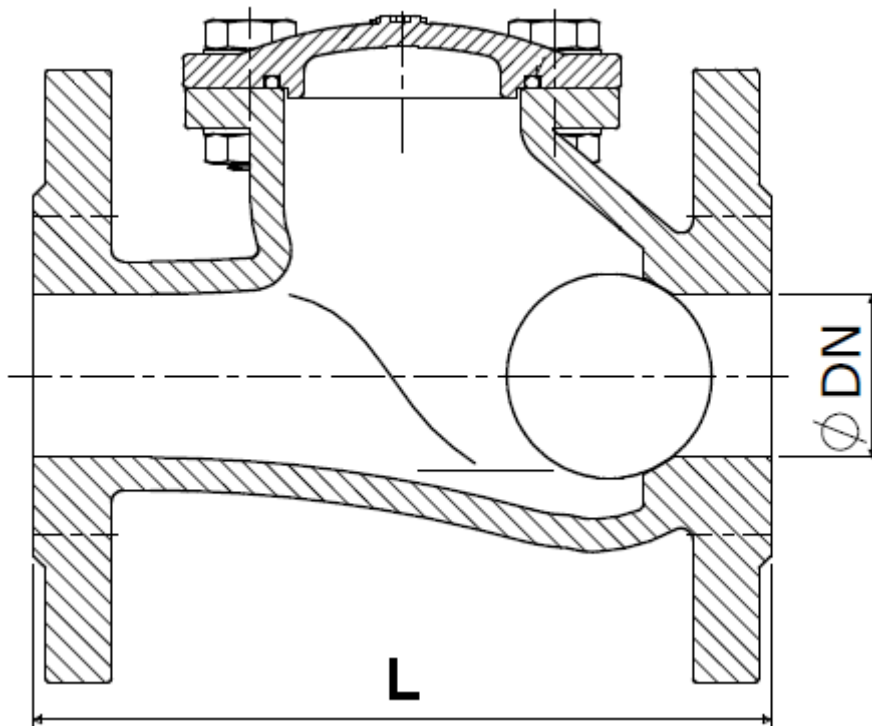

Ref.	DN	40	50	65	80	100	125	150	200	250	300
332	L	178	200	240	260	300	350	400	500	600	700
	Weight (Kg)	6.15	9.8	17.5	20.5	25.6	42.7	54	103	135	191.8

FLANGED BALL CHECK VALVE PN10**STANDARDS :**

- DIRECTIVE 97/23/CE : Products excluded from directive (Article 1, § 3.2)
- ISO PN10 Flanges according to EN 1092-2
- Length according to EN 558 series 48 (DIN 3202 F6)

INSTALLATION POSITIONS :

Vertical position (Ascendant fluid)

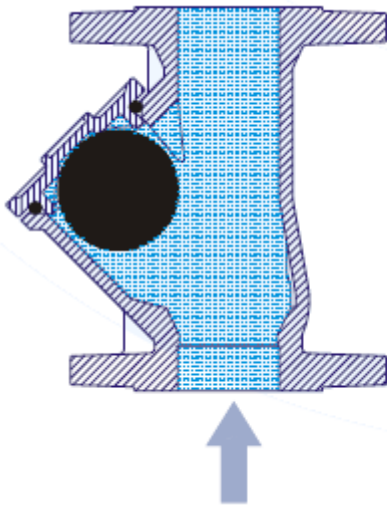

Horizontal position

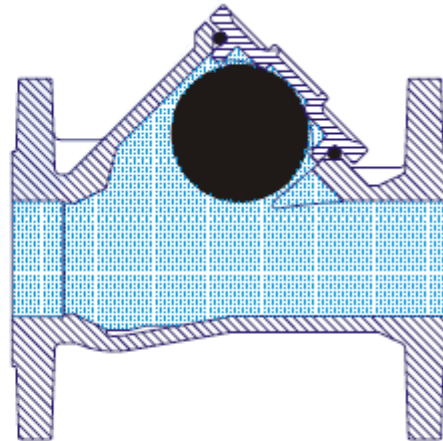

ADVICE :Our opinion and our advice are not guaranteed and Lauridsen Industri shall not be liable for the consequences of damages.

The customer must check the right choice of the products with the real service conditions.

FLANGED BALL CHECK VALVE PN10**INSTALLATION INSTRUCTIONS****GENERAL GUIDELINES :**

- Ensure that the check valves to be used are appropriate for the conditions of the installation (type of fluid, pressure and temperature).
- Be sure to have enough valves to be able to isolate the sections of piping as well as the appropriate equipment for maintenance and repair.
- Ensure that the valves to be installed are of correct strength to be able to support the capacity of their usage.

INSTALLATION INSTRUCTIONS :

- **Before installing the check valves, clean and remove any objects from the pipes** (in particular bits of sealing and metal) which could obstruct and block the valves.
- **Ensure that both connecting pipes either side of the check valve (upstream and downstream) are aligned (if they're not, the valves may not work correctly).**
- **Make sure that the two sections of the pipe (upstream and downstream) match, the check valve unit will not absorb any gaps. Any distortions in the pipes may affect the tightness of the connection, the working of the check valve and can even cause a rupture.** To be sure, place the kit in position to ensure the assembling will work.
- **If sections of piping do not have their final support in place, they should be temporarily fixed. This is to avoid unnecessary strain on the check valve.**
- Respect the flow direction indicated by the arrow
- Tighten the bolts in cross.
- If there is a direction changing or if there's another material, it's better to take away the check valve so that it is outside the turbulence area (**between 3 and 5 times the ND before and after**).
- After a pump please refer to norm NF CR 13932 to install the check valve.