

CARBON STEEL STRAINER FLANGED CLASS 150 PN20



ISO 9001 : 2015



PED 2014/68/EU



Certificate 3.1



Size : DN 50 to DN 400 (NPS 2" to 16")
Ends : Flanges R.F. Class 150 (PN20)
Min Temperature : - 29°C
Max Temperature : + 425°C
Max Pressure : 20 Bars
Specifications : Removable stainless steel filter
Bolted bonnet with draining cap

Materials : Carbon steel ASTM A216 WCB

CARBON STEEL STRAINER FLANGED CLASS 150 PN20

SPECIFICATIONS :

- Removable stainless steel filter
- Flanges R.F. Class 150 (PN20)
- Horizontal or vertical position with descendant fluid (respect the flow direction indicated by the arrow)
- Mesh 1 mm for DN50 (2"), 1.5 mm from DN65 to 400 (2"1/2 to 16")
- Bolted bonnet with draining cap threaded NPT
- Grey painting RAL 7001 color, 60 µm thickness

USE :

- Water distribution, gas oil, steam, petrochemical, petroleum industry, gas
- Min Temperature Ts : - 29°C
- Max Temperature Ts :+ 425°C
- Max Pressure Ps : 20 bars

PRESSURE / TEMPERATURE RELATION :

(According to AMSE B16-34 for A216 WCB)

Pressure (Bar)	19.6	19.6	17.9	15.8	13.8	11.7	9.6	8.6	7.6	6.5	5.5
Temperature (°C)	-29	38	93	149	204	260	316	343	371	399	425

PRESSURE / TEMPERATURE GRAPH :

Pressure

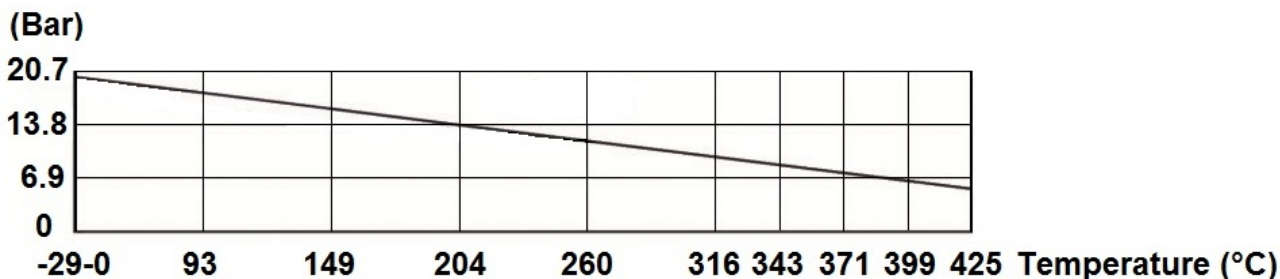

FLOW COEFFICIENT Kvs (M3 / h) :

DN (mm)	50	65	80	100	150	200	250	300	350	400
NPS (")	2"	2"1/2	3"	4"	6"	8"	10"	12"	14"	16"
Kvs (m3/h)	50	60	90	150	350	600	1000	1400	1800	2400

RANGE :

- Carbon steel strainer flanged R.F. Class 150 (PN20) **Ref. 243** from DN 50 to DN 400 (NPS from 2" to 16")

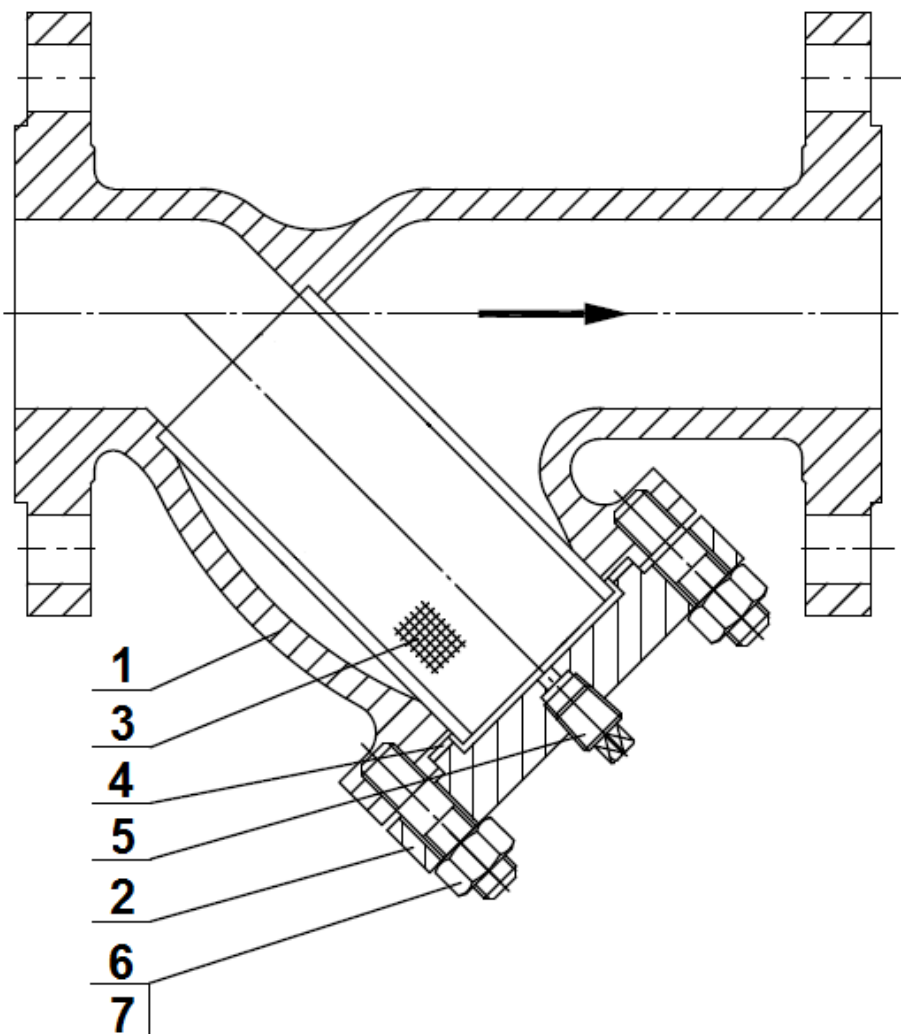
CARBON STEEL STRAINER FLANGED CLASS 150 PN20
MATERIALS :

Item	Designation	Materials
1	Body	ASTM A216 WCB
2	Bonnet	ASTM A216 WCB
3	Filter	AISI 304
4	Bonnet gasket	Graphite + AISI 304
5	Draining cap	Steel
6	Stud bolt	ASTM A193 Gr.B7
7	Nut	ASTM A194 Gr.2H

CARBON STEEL STRAINER FLANGED CLASS 150 PN20

SIZE (in mm) :

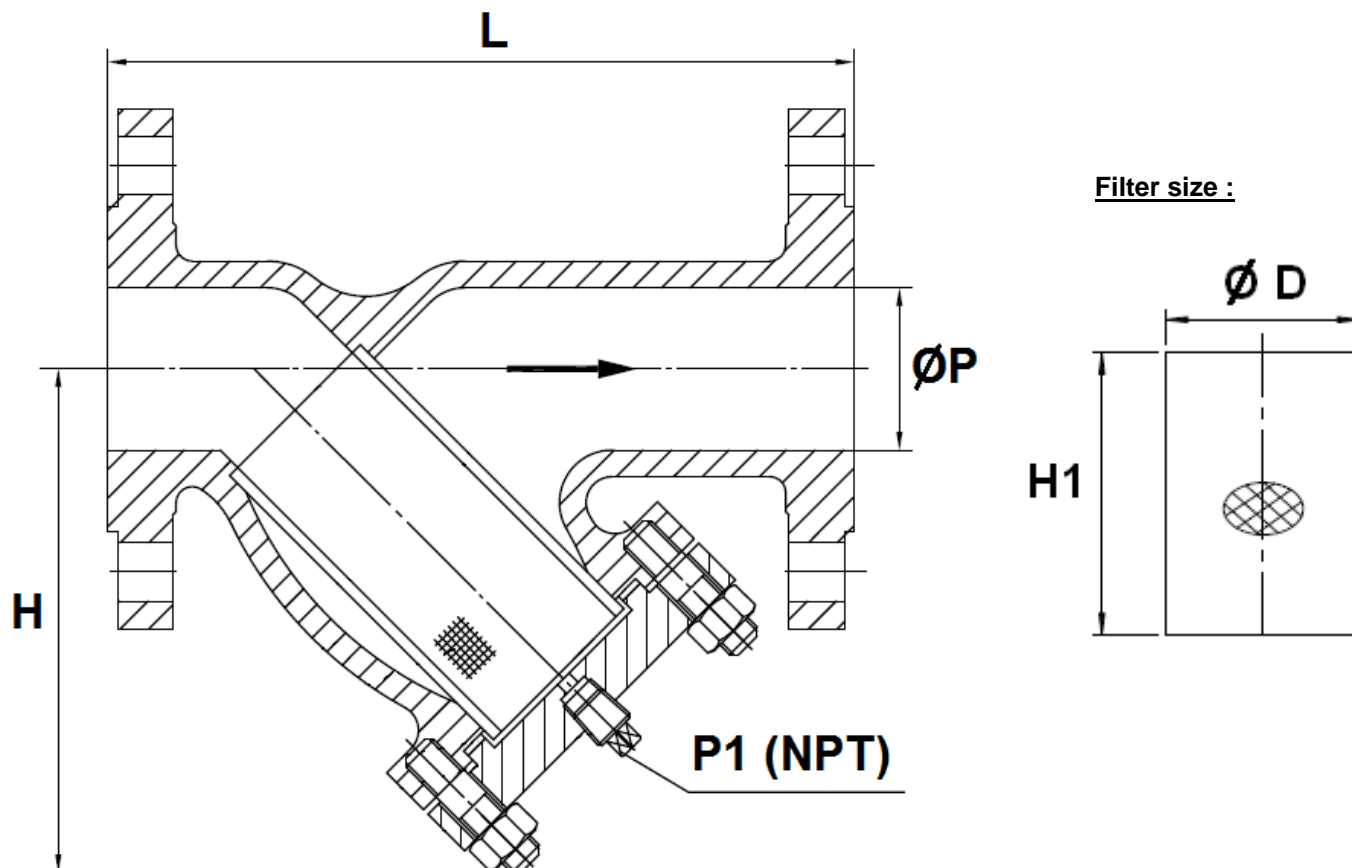

DN	50	65	80	100	150	200	250	300	350	400
NPS (")	2"	2"1/2	3"	4"	6"	8"	10"	12"	14"	16"
Ø P	50	65	80	100	150	200	250	300	350	400
L	203	216	241	292	406	495	622	699	787	914
H	146	156	175	227	283	372	443	495	695	840
P1 (drain NPT)	1/2"	1/2"	1/2"	1/2"	3/4"	3/4"	1"	1"	1"	1"
Ø D	55	60	80	105	150	190	235	280	340	390
H1	110	120	135	175	210	275	355	365	435	465
Mesh	1	1.5	1.5	1.5	1.5	1.5	1.5	1.5	1.5	1.5
Weight (Kg)	9.7	13	16	24	39	80	135	191	319	405

CARBON STEEL STRAINER FLANGED CLASS 150 PN20

FLANGES SIZE (in mm) :

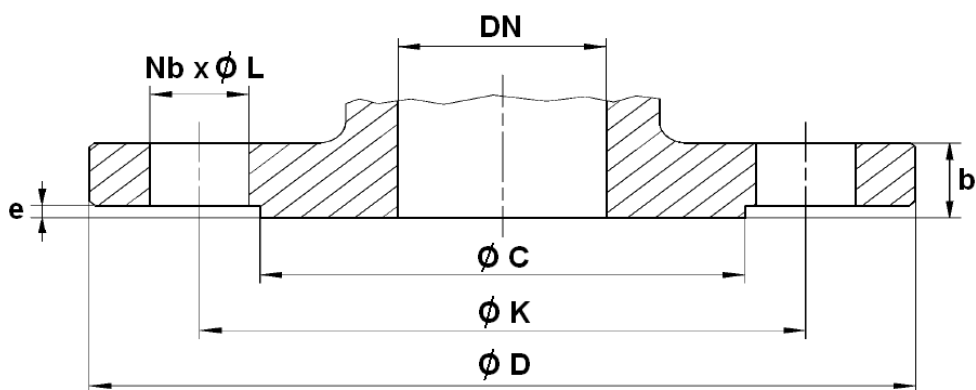

DN (mm)	50	65	80	100	150	200	250	300	350	400
NPS (")	2"	2"1/2	3"	4"	6"	8"	10"	12"	14"	16"
Ø C	92.1	104.8	127	157.2	215.9	269.9	323.8	381	412.8	469.9
Ø D	150	180	190	230	280	345	405	485	535	595
Ø K	120.7	139.7	152.5	190.5	241.5	298.5	362	432	476	540
Nb x Ø L	4 x 19	4 x 19	4 x 19	8 x 19	8 x 22	8 x 22	12 x 26	12 x 26	12 x 29	16 x 29
b	16.3	17.9	19.5	24.3	25.9	29	30.6	32.2	35.4	37
e	2	2	2	2	2	2	2	2	2	2

CARBON STEEL STRAINER FLANGED CLASS 150 PN20**STANDARDS :**

- Fabrication according to ISO 9001 : 2015 and ISO 14001 : 2015
- DIRECTIVE 2014/68/EU : CE N° 0036
Risk category III module H
- Certificate 3.1 on request
- Designing according to ASME B16.34
- Pressure tests according to API 598, table 6
- Length according to ASME B16.10 table 1 A15 series and EN 558 series 10 (EN558 series 7 for DN150 6")
- Flanges R.F. according to ASME B16.05 Class 150
- Materials according to NACE MR 01-75 **on request**

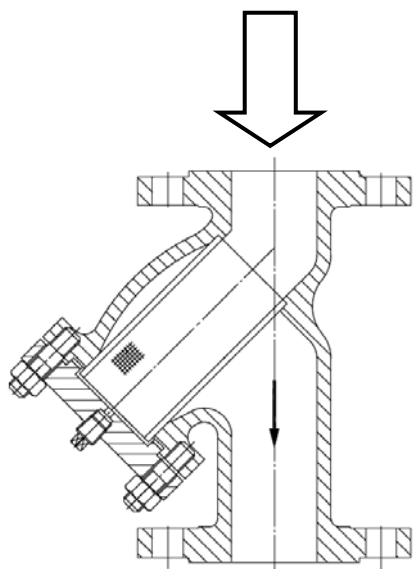
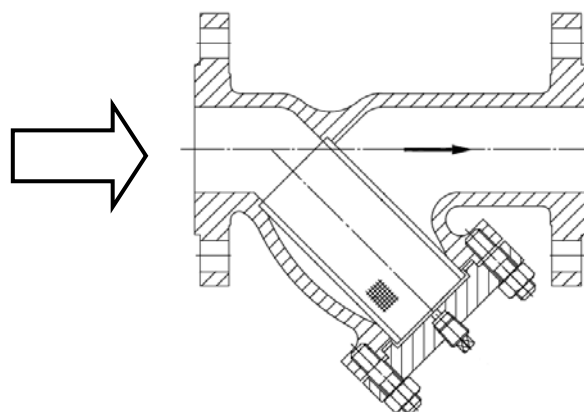
INSTALLATION POSITIONS :**Vertical position (descendand fluid)****Horizontal position**

ADVICE : Our opinion and our advice are not guaranteed and Lauridsen industri shall not be liable for the consequences of damages. The customer must check the right choice of the products with the real service conditions.

CARBON STEEL STRAINER FLANGED CLASS 150 PN20**INSTALLATION INSTRUCTIONS****GENERAL GUIDELINES :**

- Ensure that the strainers to be used are appropriate for the conditions of the installation (type of fluid, pressure and temperature).
- Be sure to have enough valves to be able to isolate the sections of piping as well as the appropriate equipment for maintenance and repair.
- Ensure that the strainers to be installed are of correct strength to be able to support the capacity of their usage.
- **Installation of all circuits should ensure that their function can be automatically tested on a regular basis (at least two times a year).**

INSTALLATION INSTRUCTIONS :

- **Before installing the strainers, clean and remove any objects from the pipes** (in particular bits of sealing and metal) which could obstruct and block the strainers.
- **Ensure that both connecting pipes either side of the strainer (upstream and downstream) are aligned (if they're not, the strainer may not work correctly).**
- **Make sure that the two sections of the pipe (upstream and downstream) match, the strainer unit will not absorb any gaps. Any distortions in the pipes may affect the tightness of the connection, the working of the strainer and can even cause a rupture.** To be sure, place the kit in position to ensure the assembling will work.
- Make sure flanges are cleaned.
- **If sections of piping do not have their final support in place, they should be temporarily fixed. This is to avoid unnecessary strain on the strainer.**
- Tighten the bolts in cross.
- The pressurisation must be increased gradually.
- So that the maintenance operations could be easily done, place a stop valve before and after the strainer. Thereby, the strainer could be isolated. During this operation, ensure to have a new bonnet gasket to avoid a leakage during the restarting.
- **Fluids in the strainer must not contain solid objects (it could damage the seat).**