

**STRAINER BASKETS FOR PN10/16 FLANGES**



ISO 9001 : 2015  
BUREAU VERITAS  
Certification



ISO 14001:2015  
BUREAU VERITAS  
Certification



**Size :** DN 50 to 300  
**Ends :** For flanges PN10/16  
**Min Temperature :** - 20°C  
**Max Temperature :** + 200°C  
**Max Pressure :** 16 Bars  
**Specifications :** Mesh 6 mm  
With bolting

**Materials :** Steel or stainless steel

## STRAINER BASKETS FOR PN10/16 FLANGES

### SPECIFICATIONS :

- For flanges PN10/16
- Mesh 6 mm
- With bolting

### USE :

- For water distribution and draining
- Min Temperature Ts : - 20°C
- Max Temperature Ts :+ 200°C
- Max Pressure Ps : 16 bars

### RANGE :

- Galvanized carbon steel strainer basket, for PN10/16 flanges from DN50 to DN 300 **Ref. 367**
- AISI 304 strainer basket, for PN10/16 flanges from DN50 to DN 300 **Ref. 376**

### MATERIALS :

**REF. 367**



**REF. 376**



Designation	Materials Ref. 367	Materials Ref.376
Body	Galvanized carbon steel	AISI 304

STRAINER BASKETS FOR PN10/16 FLANGES

**SIZE CARBON STEEL TYPE REF.367 ( in mm ) :**

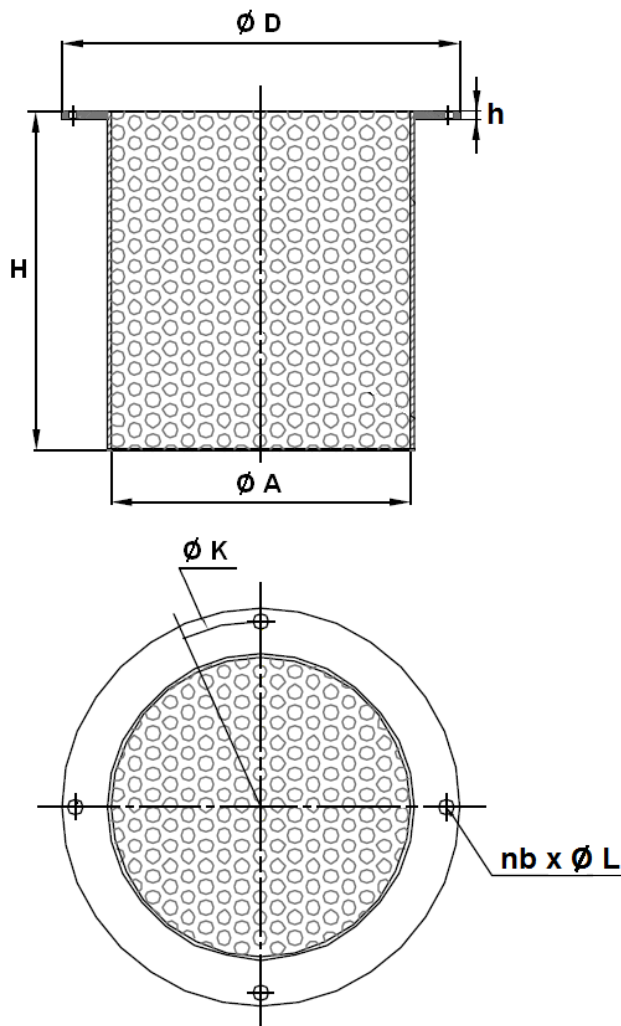

Ref.	DN	50	65	80	100	125	150	200	250	300
<b>367</b>	H	77	110	125	155	170	220	300	390	410
	h	3	3	3	3	3	3	3	4	4
	$\varnothing A$	93	113	128	148	178	200	255	310	360
	$\varnothing D$	165	185	200	220	250	285	340	397	450
	$\varnothing K$	125	145	160	180	210	240	295	355	410
	Nb x $\varnothing L$	4 x 18	4 x 18	4 x 18	4 x 18	4 x 18	4 x 22	4 x 22	12 x 22	12 x 22
	Weight ( Kg )	1	1.3	1.4	1.7	2	3	4.5	6	7
	Ref.	367050	367065	367080	367100	367125	367150	367200	367250	367300

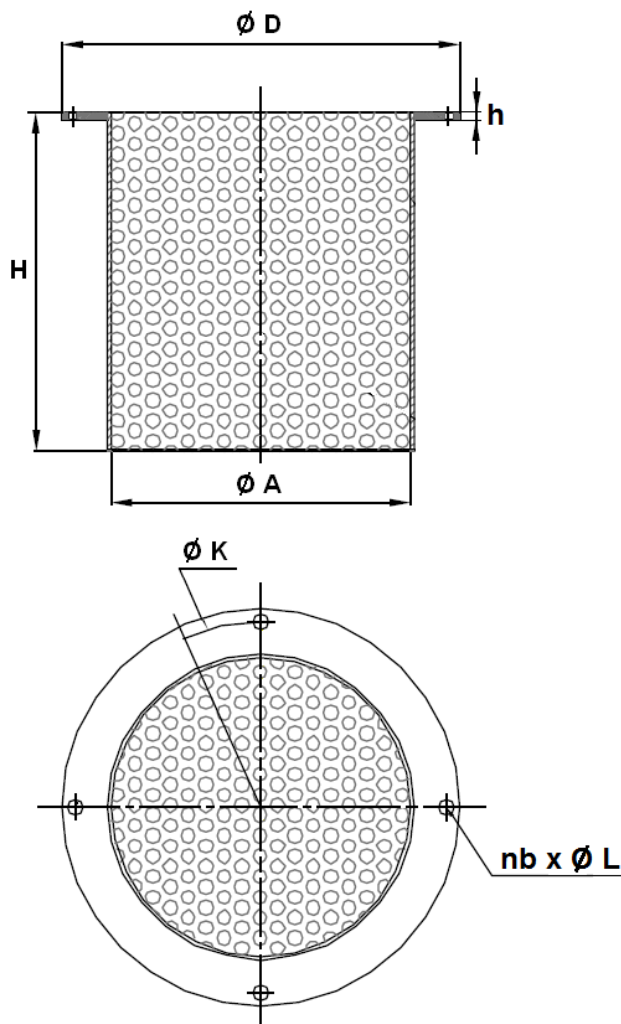
**STRAINER BASKETS FOR PN10/16 FLANGES**
**SIZE STAINLESS STEEL TYPE REF.376 ( in mm ) :**

Ref.	DN	50	65	80	100	125	150	200	250	300
376	H	77	110	125	155	170	220	300	390	410
	h	3	3	3	3	3	3	3	4	4
	$\varnothing A$	93	113	128	148	178	200	255	310	360
	$\varnothing D$	165	185	200	220	250	285	340	397	450
	$\varnothing K$	125	145	160	180	210	240	295	355	410
	Nb x $\varnothing L$	4 x 18	4 x 18	4 x 18	4 x 18	4 x 18	4 x 22	4 x 22	12 x 22	12 x 22
	Weight ( Kg )	1	1.3	1.4	1.7	2	3	4.5	6	7
	Ref.	376050	376065	376080	376100	376125	376150	376200	376250	376300

## STRAINER BASKETS FOR PN10/16 FLANGES

**STANDARDS :**

- Fabrication according to ISO 9001: 2015 and ISO 14001 : 2015
- DIRECTIVE 2014/68/EU : Products excluded from directive (article 1, § 2b)

**ADVICE :** Our opinion and our advice are not guaranteed and Lauridsen industri shall not be liable for the consequences of damages. The customer must check the right choice of the products with the real service conditions.