

**2 PIECES F316L BALL VALVE WITH WELDING ENDS CLASS 800**



ISO 9001 : 2015



PED 2014/68/UE



Certificate 3.1

NACE



**Size :** DN 8 to DN 50  
**Ends :** Butt Welding, Socket welding or straight welding  
**Min Temperature :** - 30°C  
**Max Temperature :** + 180°C  
**Max Pressure :** 132 Bars (Class 800)  
**Specifications :** Anti blow-out stem  
Fire safe  
Full bore

**Materials :** Stainless steel ASTM A276 316L

**2 PIECES F316L BALL VALVE WITH WELDING ENDS CLASS 800**
**SPECIFICATIONS :**

- Full bore
- Anti blow-out stem
- Ends 100 mm But Welding schedule 80 , or socket welding or straight welding
- Class 800
- Fire safe according to BS 6755 part.2
- ATEX
- Antistatic device
- 2 pieces type
- NACE MR01-75

**USE :**

- Chemical and pharmaceutical industries, petrochemical industries, hydraulic installation, compressed air
- Min and max Temperature Ts : - 30°C to + 180°C
- Max Pressure Ps : 132 bars
- Steam : 5 bars maximum

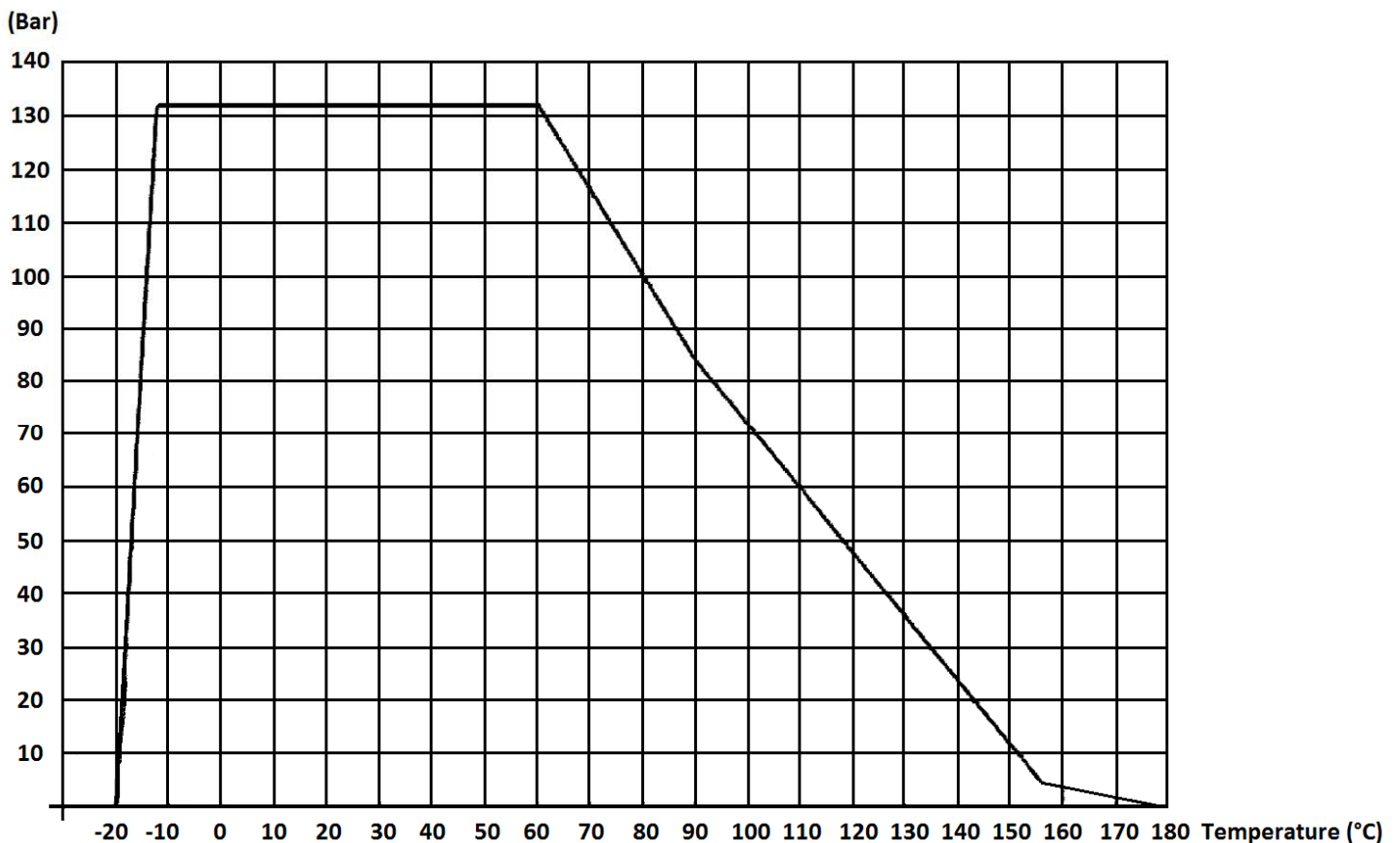
**PRESSURE / TEMPERATURE GRAPH :**
**PRESSURE**

**2 PIECES F316L BALL VALVE WITH WELDING ENDS CLASS 800**
**RANGE :**

- Ball valve class 800 forged F316L body and welding ends **Ref. 719 / 7191 / 7192** from DN 8 to DN 50



- Stainless steel 304 with red cover handle

DN	8-10	15	20-25	32-40	50
Ref.	9830320	9830316	9830317	9830318	9830321



- Locking device (with padlock)

DN	8-10	15	20-25	32-40	50
Ref.	9830301	9830313	9830314	9830315	9830496



- Galvanized steel handwheel

DN	8-10	15	20-25	32-40	50
Ref.	9830571	9830572	9830573	9830574	

**ENDS :**

- Butt Welding ends schedule 80 **Ref. 719**
- Straight welding ends **Ref. 7191** (on request)
- Socket Welding ends **Ref. 7192** (on request)

**2 PIECES F316L BALL VALVE WITH WELDING ENDS CLASS 800**

MATERIALS BUTT WELDING ENDS TYPES 719 :

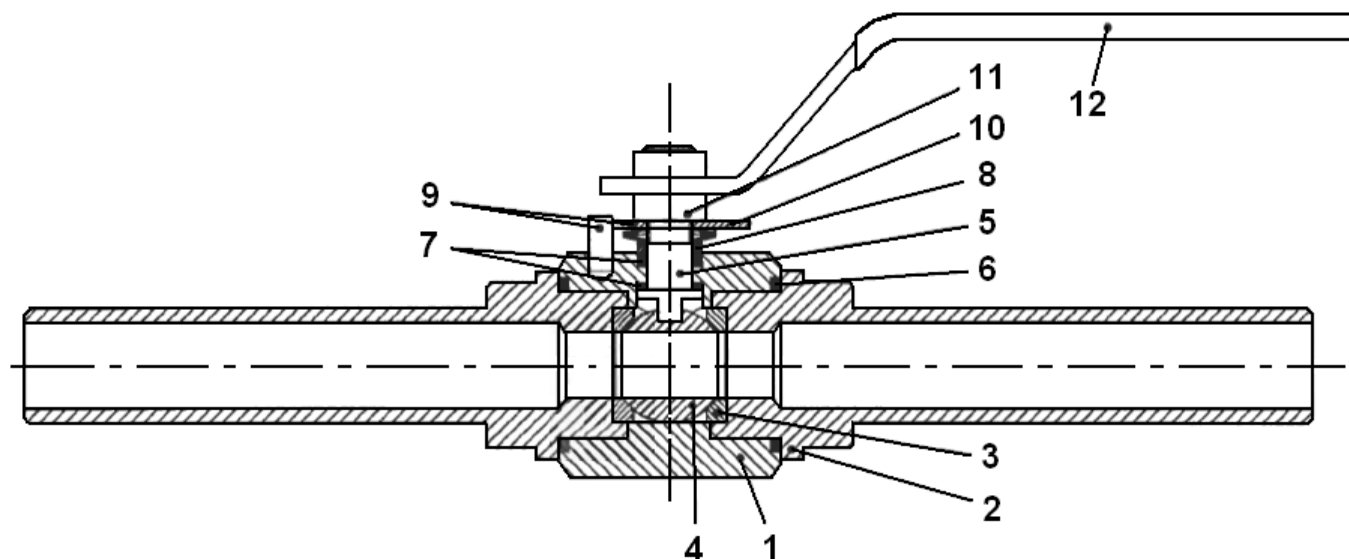

Item	Designation	Materials
1	Body	ASTM A276 316L
2	Ends	
3	Seat	PTFE + carbongraphite
4	Ball	ASTM A276 316L
5	Stem	
6	Body gasket	Carbongraphite
7	Stem gasket	Carbongraphite
8	Packing gland	AISI 304
9	Stop	FE P11 ( UNI 5867 )
10	Disc springs	Steel
11	Nut	Steel 6S
12	Handle	FE P11 ( UNI 5867 )

**2 PIECES F316L BALL VALVE WITH WELDING ENDS CLASS 800**

MATERIALS STRAIGHT WELDING ENDS TYPES 7191 :

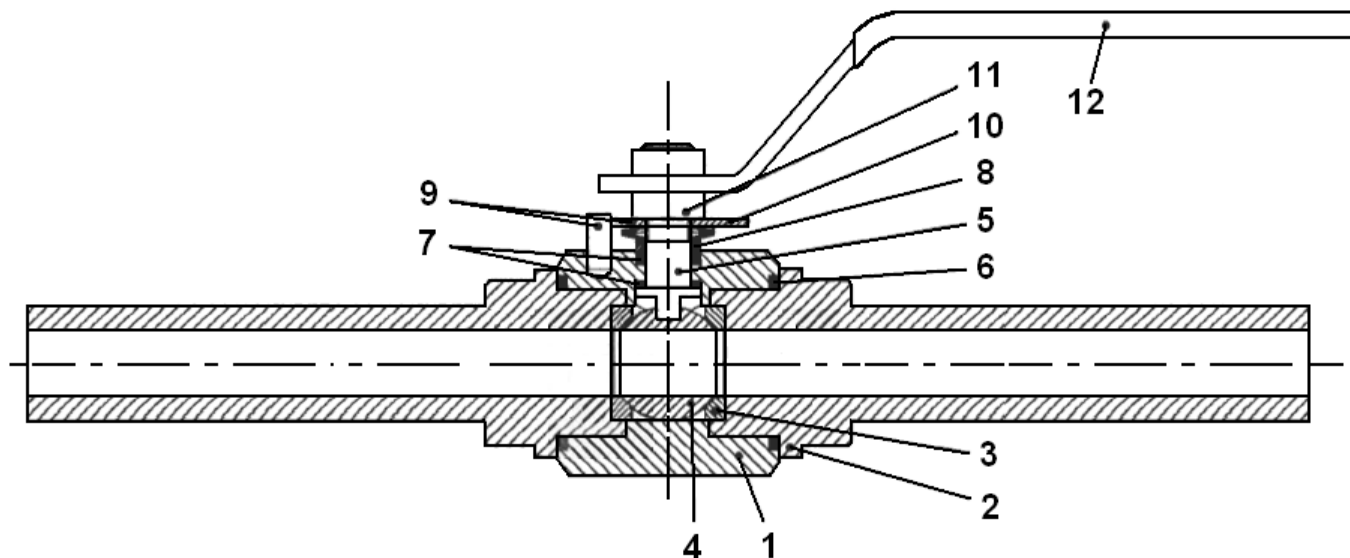

Item	Designation	Materials 7191
1	Body	ASTM A276 316L
2	Ends	
3	Seat	PTFE + carbongraphite
4	Ball	ASTM A276 316L
5	Stem	
6	Body gasket	Carbongraphite
7	Stem gasket	Carbongraphite
8	Packing gland	AISI 304
9	Stop	FE P11 ( UNI 5867 )
10	Disc springs	Steel
11	Nut	Steel 6S
12	Handle	FE P11 ( UNI 5867 )

**2 PIECES F316L BALL VALVE WITH WELDING ENDS CLASS 800**

MATERIALS SOCKET WELDING ENDS TYPES. 7192 :

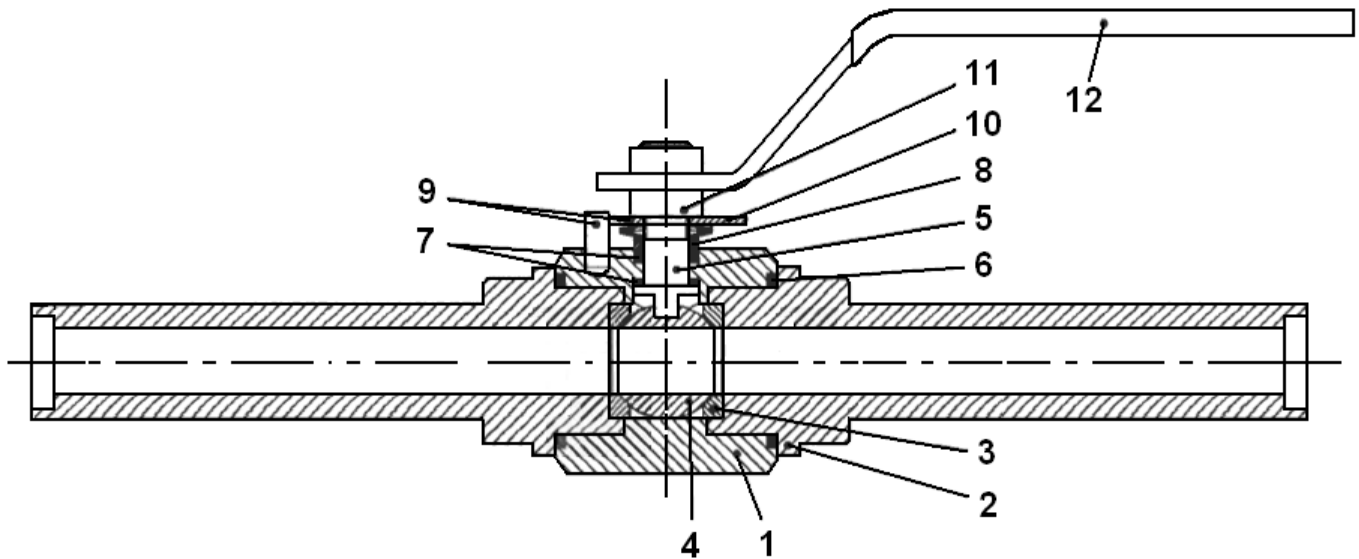

Item	Designation	Materials 7192
1	Body	ASTM A276 316L
2	Ends	
3	Seat	PTFE + carbongraphite
4	Ball	ASTM A276 316L
5	Stem	
6	Body gasket	Carbongraphite
7	Stem gasket	Carbongraphite
8	Packing gland	AISI 304
9	Stop	FE P11 ( UNI 5867 )
10	Disc springs	Steel
11	Nut	Steel 6S
12	Handle	FE P11 ( UNI 5867 )

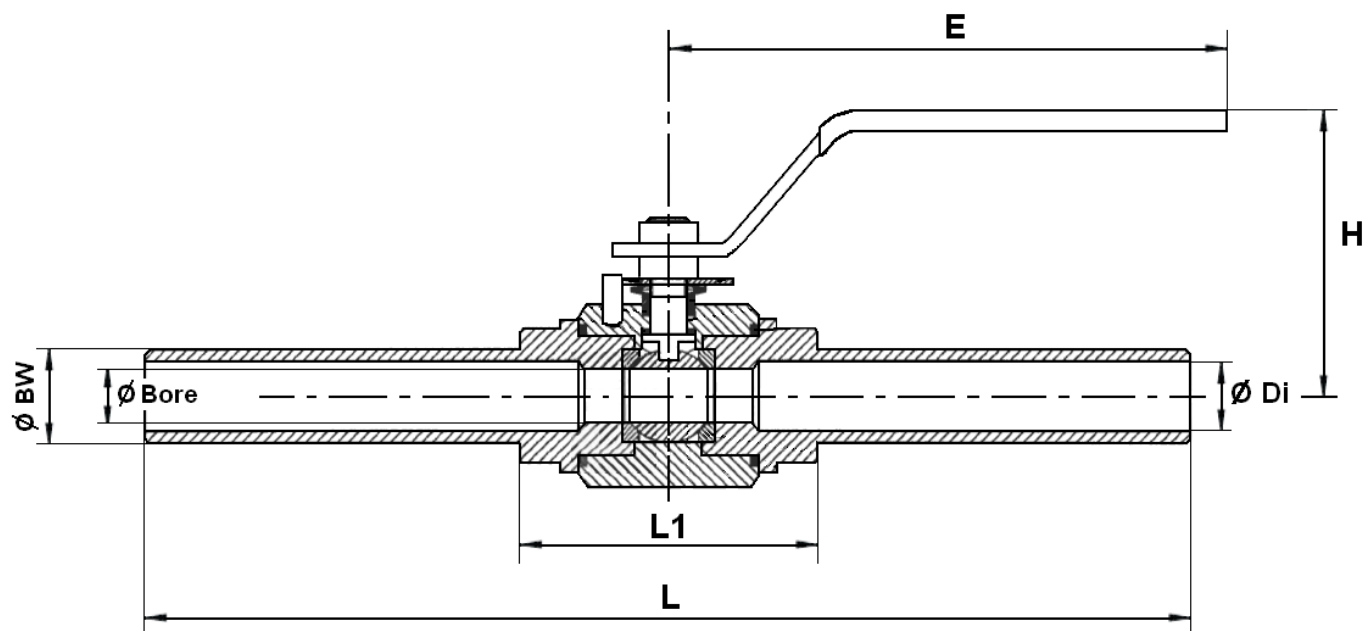
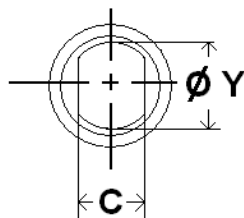
**2 PIECES F316L BALL VALVE WITH WELDING ENDS CLASS 800**
SIZE BUTT WELDING ENDS TYPES 719 ( in mm ) :

Stem size :

Ref.	DN	8	10	15	20	25	32	40	50
719	Ø Bore	10	10	15	20	25	30	38	48
	L	267	267	275	290	310	320	335	355
	L1	67	67	75	90	105	120	135	155
	E	148	148	148	180	180	240	240	280
	H	72	72	75	85	95	100	105	115
	Ø BW	13.5	17.2	21.3	26.7	33.4	42.2	48.3	60.3
	Ø Di	7.7	10.8	13.9	18.8	24.3	32.5	38.1	49.2
	C	5	5	5.5	7.5	7.5	9	9	9
	Ø Y	8	8	10	12	12	14	14	14
	Weight (in Kg)	0.6	0.6	1	2	4	5.5	7	9

**2 PIECES F316L BALL VALVE WITH WELDING ENDS CLASS 800**

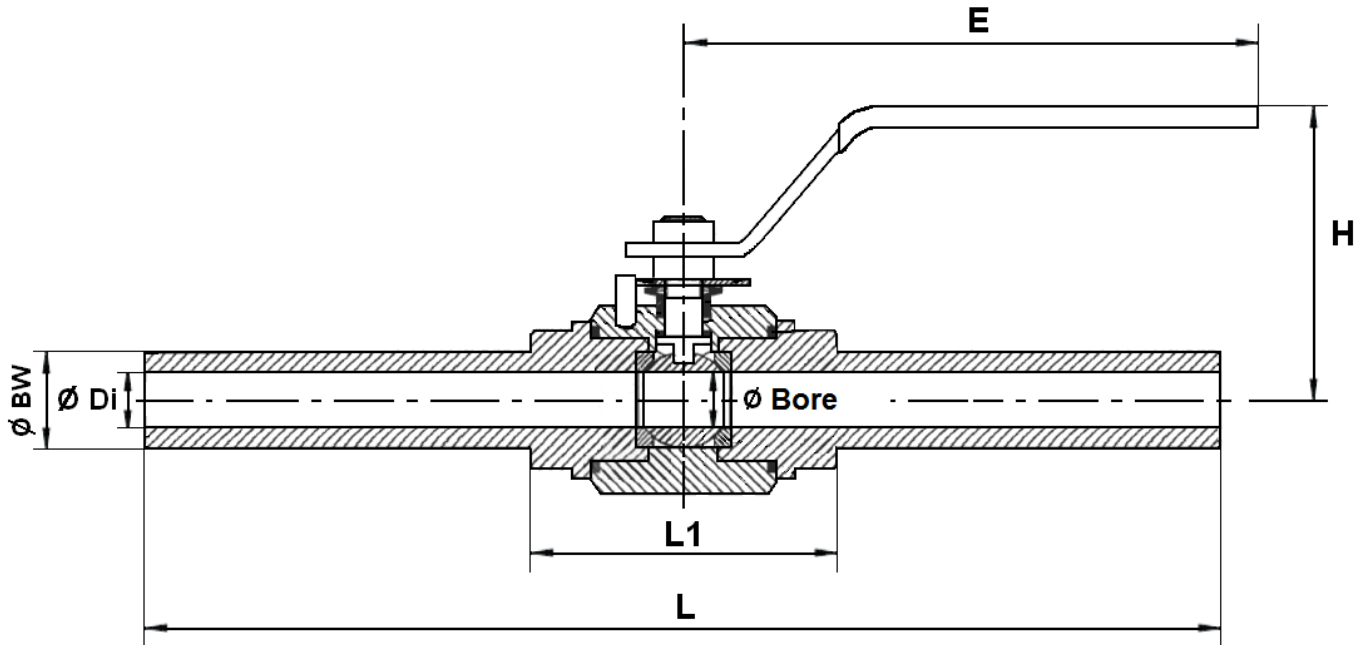
SIZE STRAIGHT WELDING ENDS TYPES 7191 ( in mm ) :



Stem size :

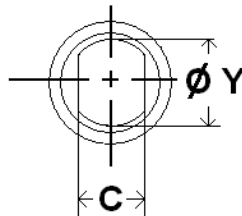

Ref.	DN	8	10	15	20	25	32	40	50
7191	Ø Bore	10	10	15	20	25	30	38	48
	L	267	267	275	290	310	320	335	355
	L1	67	67	75	90	105	120	135	155
	E	148	148	148	180	180	240	240	280
	H	72	72	75	85	95	100	105	115
	Ø BW	13.5	17.2	21.3	26.7	33.4	42.2	48.3	60.3
	Ø Di	7.7	10.8	13.9	18.8	24.3	32.5	38.1	49.2
	C	5	5	5.5	7.5	7.5	9	9	9
	Ø Y	8	8	10	12	12	14	14	14
	Weight (in Kg)	0.6	0.6	1	2	4	5.5	7	9

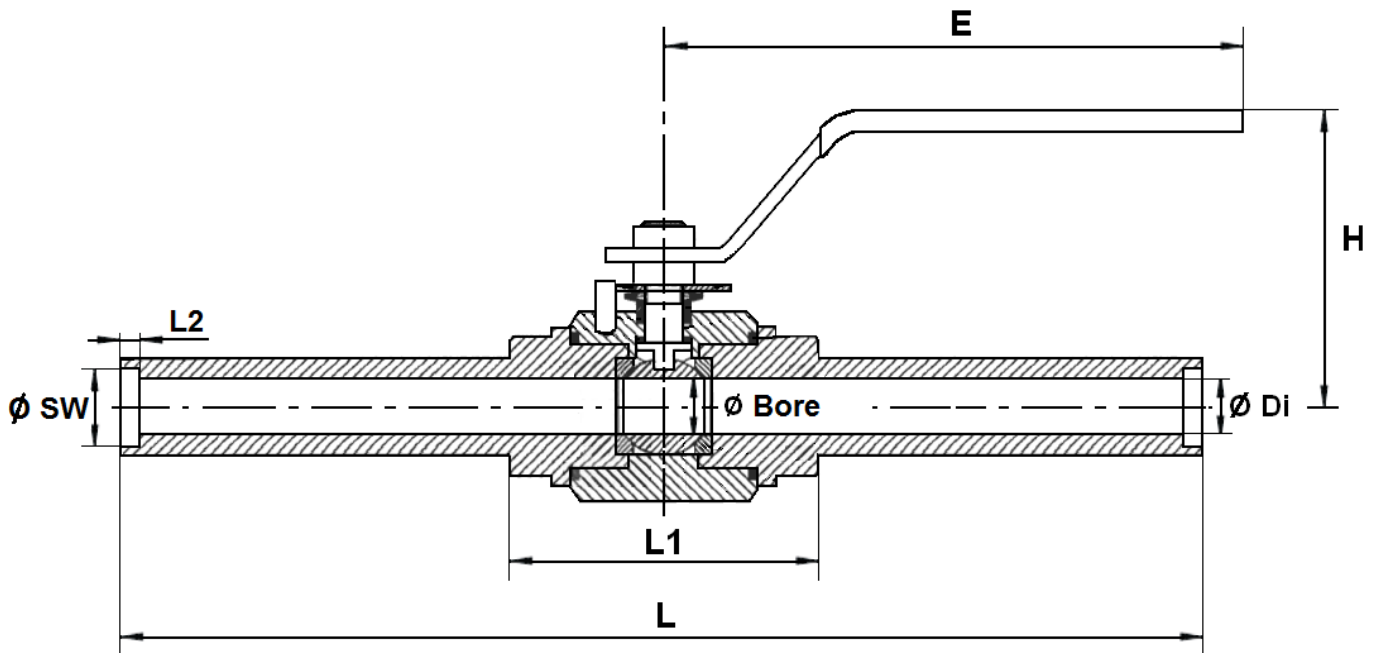
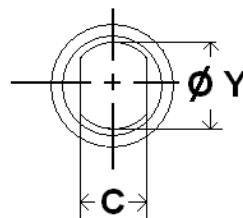

**2 PIECES F316L BALL VALVE WITH WELDING ENDS CLASS 800**
SIZE SOCKET WELDING ENDS TYPES 7192 ( in mm ) :

Stem size :

Ref.	DN	8	10	15	20	25	32	40	50
7192	Ø Bore	10	10	15	20	25	30	38	48
	L	267	267	275	290	310	320	335	355
	L1	67	67	75	90	105	120	135	155
	E	148	148	148	180	180	240	240	280
	H	72	72	75	85	95	100	105	115
	Ø SW	14.3	17.8	21.8	27.3	34	42.6	48.7	61.3
	L2	9.5	9.5	9.5	11.5	13	14	16	17
	Ø Di	7.7	10.8	13.9	18.8	24.3	32.5	38.1	49.2
	C	5	5	5.5	7.5	7.5	9	9	9
	Ø Y	8	8	10	12	12	14	14	14
Weight (in Kg)	0.6	0.6	1	2	4	5.5	7	9	

**2 PIECES F316L BALL VALVE WITH WELDING ENDS CLASS 800**

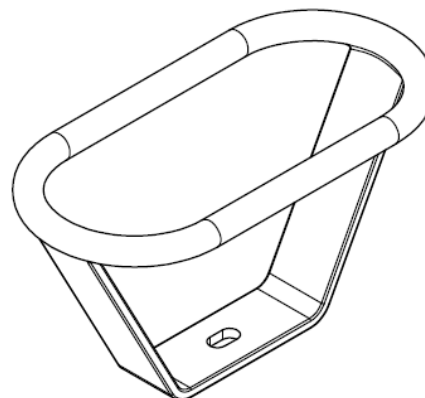
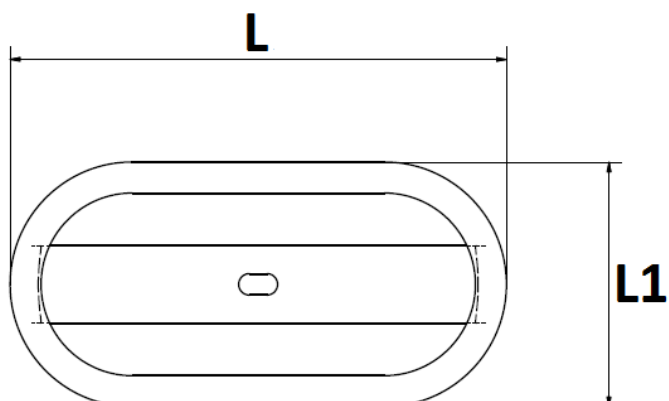
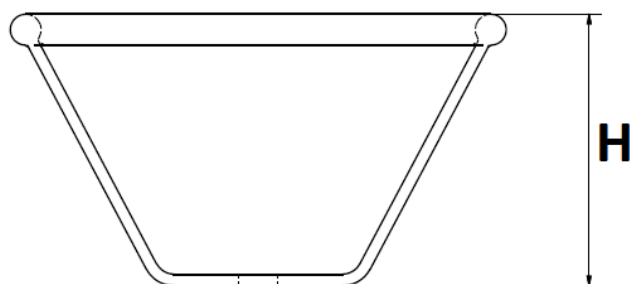
HANDWHEEL SIZE ( in mm ):



DN	1/4"	3/8"	1/2"	3/4"	1"	1"1/4"	1"1/2"	2"
H	70	70	70	64	64	80	80	80
L	128	128	128	130	130	205	205	205
L1	63	63	63	82	82	105	105	105
Ref.	9830571	9830571	9830572	9830573	9830573	9830574	9830574	9830574
Weight (in Kg)	0.300	0.300	0.380	0.420	0.420	0.460	0.460	0.460

**2 PIECES F316L BALL VALVE WITH WELDING ENDS CLASS 800****STANDARDS :**

- Fabrication according to ISO 9001 : 2015
- DIRECTIVE 2014/68/EU : CE N° 0948  
Risk category III Module B+C2
- Pressure tests according to API 598, table 6
- Butt Welding ends according to ANSI B16.25
- Fire safe according to B.S. 6755 part.2
- Materials according to NACE MR 01-75
- ATEX Group II Category 2 G/2D Zone 1 & 21 Zone 2 & 22 ( optional marking )

**ADVICE :** Our opinion and our advice are not guaranteed and SFERACO shall not be liable for the consequences of damages.  
The customer must check the right choice of the products with the real service conditions.

**INSTALLATION AND MAINTENANCE****BEFORE INSTALLATION :**

Pipe-line must be cleaned and free from residual of weldings, rubbish, shaving and every kind of extraneous materials.  
Pipe-line must be perfectly aligned and their support properly dimensioned so that there's no external constraint.

Please use the right product according to the services conditions to seal the valve.  
Use the right bolt tightening so that the ends won't be damaged.

**CLEANING AND TESTS**

Keep closed the valves during the cleaning operation so that there's no impurities between the ball and the body.

Tests under pressure must be done with a cleaned pipe-line.

Open partially the valve for tests. Pressure test do not exceed the valve specifications according to API 598.

**MAINTENANCE**

It's recommended to operate the valve ( open and close ) 1 to 2 times per year.

When intervention on the valve, be sure there's no pressure in the pipe-line, there's no fluid in it, and that it is isolated.  
The temperature must be low enough to operate without risks.  
If there's a corrosive fluid, inert installation before intervention.